

MISCELLANEOUS ITEMS

Front Filler Scribes



Width	Standing Ht.		Sitting Ht.		ADA Ht.		84" High	
	Right Hand	Left Hand	Right Hand	Left Hand	Right Hand	Left Hand	Right Hand	Left Hand
1"	FFR1001	FFL1001	FFR2001	FFL2001	FFR8001	FFL8001	FFR3001	FFL3001
2"	FFR1002	FFL1002	FFR2002	FFL2002	FFR8002	FFL8002	FFR3002	FFL3002
4"	FFR1004	FFL1004	FFR2004	FFL2004	FFR8004	FFL8004	FFR3004	FFL3004
6"	FFR1006	FFL1006	FFR2006	FFL2006	FFR8006	FFL8006	FFR3006	FFL3006
8"	FFR1008	FFL1008	FFR2008	FFL2008	FFR8008	FFL8008	FFR3008	FFL3008
10"	FFR1010	FFL1010	FFR2010	FFL2010	FFR8010	FFL8010	FFR3010	FFL3010
12"	FFR1012	FFL1012	FFR2012	FFL2012	FFR8012	FFL8012	FFR3012	FFL3012

- The Front Filler Scribe is used to close a space between a base cabinet and a wall.
- A double angle is provided to enclose the raw edge of the panel.
- Filler panels can be ordered in 1" increments, up to 24" wide. Change the last two digits to the dimension required.
- Right hand shown.
- Use option code "OL" when ordering Architectural Overlay design.

Front Filler Panels



Width	Standing Ht.	Sitting Ht.	ADA Ht.	84" High
1"	FFC1001	FFC2001	FFC8001	FFC3001
2"	FFC1002	FFC2002	FFC8002	FFC3002
4"	FFC1004	FFC2004	FFC8004	FFC3004
6"	FFC1006	FFC2006	FFC8006	FFC3006
8"	FFC1008	FFC2008	FFC8008	FFC3008
10"	FFC1010	FFC2010	FFC8010	FFC3010
12"	FFC1012	FFC2012	FFC8012	FFC3012
24"	FFC1024	FFC2024	FFC8024	FFC3024

- The Front Filler Panel is used to close a space between two base cabinets.
- Filler panels can be ordered in 1" increments, up to 24" wide. Change the last two digits to the dimension required.
- Use option code "OL" when ordering Architectural Overlay design.

Corner Filler Panels



Width & Depth	Standing Ht.	Sitting Ht.	ADA Ht.
1" x 1"	CFC1001	CFC2001	CFC8001
2" x 2"	CFC1002	CFC2002	CFC8002
4" x 4"	CFC1004	CFC2004	CFC8004
6" x 6"	CFC1006	CFC2006	CFC8006

- The Corner Filler Panel is used to close a corner space between two base cabinets.
- Filler panels can be ordered in 1" increments, up to 24" wide. Change the last two digits to the dimension required.
- Use option code "OL" when ordering Architectural Overlay design.

Corner Filler Panel Scribes



Width & Depth	Standing Ht.	Sitting Ht.	ADA Ht.	84" High
1" x 1"	CFS1001	CFS2001	CFS8001	CFS3001
2" x 2"	CFS1002	CFS2002	CFS8002	CFS3002
4" x 4"	CFS1004	CFS2004	CFS8004	CFS3004
6" x 6"	CFS1006	CFS2006	CFS8006	CFS3006

- The Corner Filler Panel Scribes are used to close a corner space between two base cabinets.
- Filler Panel Scribes can be ordered in 1" increments, up to 24" wide. Change the last two digits to the dimension required.
- Two double angles are provided to enclose the raw edges of the panel.
- Use option code "OL" when ordering Architectural Overlay design.

MISCELLANEOUS ITEMS

Adjustable Corner Fillers

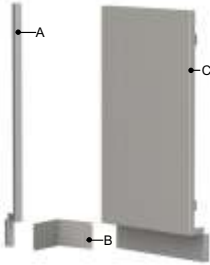

Item	Standing Ht.	Sitting Ht.	ADA Ht.
A	FFC1001	FFC2001	FFC8001
B	9900001	9900001	9900001
C	FFC1018	FFC2018	FFC8018

- The items A, B, & C combine to make the Adjustable Corner Filler Panel.
- This panel is used to close a corner space between two base cabinets. It offers the added advantage of being adjustable to enclose spaces up to 14" wide.
- Use option code "OL" when ordering Architectural Overlay design.

End Cover Panel Scribes



Width	Standing Ht.	Sitting Ht.	ADA Ht.	84"High
1"	ECS1001	ECS2001	ECS5001	ECS3001
4"	ECS1004	ECS2004	ECS5004	ECS3004
7"	ECS1007	ECS2007	ECS5007	ECS3007
8"	ECS1008	ECS2008	ECS5008	ECS3008
10"	ECS1010	ECS2010	ECS5010	ECS3010
11"	ECS1011	ECS2011	ECS5011	ECS3011
120mm	ECS100A	ECS200A	ECS500A	ECS300A
266mm	ECS100B	ECS200B	ECS500B	ECS300B

- The End Cover Panel Scribes are used to close spaces between the back of a base cabinet and a wall. The Scribe feature allows for easy width adjustment in the field.
- Filler panels can be ordered in 1" increments, up to 24" wide. Change the last two digits to the dimension required.

End Cover Channels



Width	Standing Ht.	Sitting Ht.	ADA Ht.	84"High
1"	ECC1001	ECC2001	ECC5001	ECC3001
2"	ECC1002	ECC2002	ECC5004	ECC3004
4"	ECC1004	ECC2004	ECC5007	ECC3007
7"	ECC1007	ECC2007	ECC5008	ECC3008
10"	ECC1010	ECC2010	ECC5010	ECC3010
13"	ECC1013	ECC2013	ECC5013	ECC3013
14"	ECC1014	ECC2014	ECC5011	ECC3011
120mm	ECC100A	ECC200A	ECC500A	ECC300A

- The End Cover Channel performs the same task as the End Cover Panel Scribe but is of a fixed width.
- Filler panels can be ordered in 1" increments, up to 24" wide. Change the last two digits to the dimension required.

MISCELLANEOUS ITEMS

Finished Back Panels



Width	Standing Ht.	Sitting Ht.	ADA Ht.
15"	FBP1015	FBP2015	FBP6015
18"	FBP1018	FBP2018	FBP6018
24"	FBP1024	FBP2024	FBP6024
30"	FBP1030	FBP2030	FBP6030
36"	FBP1036	FBP2036	FBP6036
42"	FBP1042	FBP2042	FBP6042
48"	FBP1048	FBP2048	FBP6048

- Finished Back Panels are used to close off the back of a base cabinet when the back is in plain view.
- Add option code 15 for a welded back on a cabinet.

Extended Finished Back Panels



Width	Standing Ht.		Sitting Ht.		ADA Ht.	
	4"Depth	18"Depth	4"Depth	18"Depth	4"Depth	18"Depth
15"	FEA1504	FEA1518	FEC1504	FEC1518	FED1504	FED1518
18"	FEA1804	FEA1818	FEC1804	FEC1818	FED1804	FED1818
24"	FEA2404	FEA2418	FEC2404	FEC2418	FED2404	FED2418
30"	FEA3004	FEA3018	FEC3004	FEC3018	FED3004	FED3018
36"	FEA3604	FEA3618	FEC3604	FEC3618	FED3604	FED3618
42"	FEA4204	FEA4218	FEC4204	FEC4218	FED4204	FED4218
48"	FEA4804	FEA4818	FEC4804	FEC4818	FED4804	FED4818
60"	FEA6004	FEA6018	FEC6004	FEC6018	FED6004	FED6018
72"	FEA7204	FEA7218	FEC7204	FEC7218	FED7204	FED7218

- Extended Finished Back Panels are used to close off the back of a base cabinet when the back is in plain view.
- Panels are available in 1" increments from 4" - 18"Deep. Change the last two digits to the dimension required.
- Corner gussets are welded into top and bottom corners.

Single Angles



Length	1" x 1"	2" x 2"
28-1/2"	SAG110C	SAG220C
31-1/2"	SAG110B	SAG220B
34-1/2"	SAG110A	SAG220A
18"	SAG1118	SAG2218
24"	SAG1124	SAG2224
36"	SAG1136	SAG2236
48"	SAG1148	SAG2248
60"	SAG1160	SAG2260
72"	SAG1172	SAG2272
84"	SAG1184	SAG2284

Double Angles



Length	1" x 1"
28-1/2"	DAG110C
31-1/2"	DAG110B
34-1/2"	DAG110A
18"	DAG1118
24"	DAG1124
36"	DAG1136
48"	DAG1148
60"	DAG1160
72"	DAG1172
84"	DAG1184

MISCELLANEOUS ITEMS

Front Wall Filler Scribes - 14" Deep



- The Wall Filler Scribe is used to close a space between a wall cabinet and a wall. It can be cut to fit gaps of various sizes.
- A double angle is provided to enclose the raw edge of the panel.
- Filler panels can be ordered in 1" increments, up to 24" wide. Change the last two digits to the dimension required.
- Use option code "OL" when ordering Architectural Overlay design.

Width	24" High	30" High	36" High	48" High
1"	WFS5301	WFS6301	WFS7301	WFS8301
2"	WFS5302	WFS6302	WFS7302	WFS8302
3"	WFS5303	WFS6303	WFS7303	WFS8303
4"	WFS5304	WFS6304	WFS7304	WFS8304
6"	WFS5306	WFS6306	WFS7306	WFS8306
8"	WFS5308	WFS6308	WFS7308	WFS8308
10"	WFS5310	WFS6310	WFS7310	WFS8310
12"	WFS5312	WFS6312	WFS7312	WFS8312
15"	WFS5315	WFS6315	WFS7315	WFS8315
18"	WFS5318	WFS6318	WFS7318	WFS8318
24"	WFS5324	WFS6324	WFS7324	WFS8324

Front Wall Fillers - 14" Deep



- The Wall Filler Scribe is used to close a space between two wall cabinets.
- Filler panels can be ordered in 1" increments, up to 24" wide. Change the last two digits to the dimension required.
- Use option code "OL" when ordering Architectural Overlay design.

Width	24" High	30" High	36" High	48" High
1"	WFP5301	WFP6301	WFP7301	WFP8301
2"	WFP5302	WFP6302	WFP7302	WFP8302
3"	WFP5303	WFP6303	WFP7303	WFP8303
4"	WFP5304	WFP6304	WFP7304	WFP8304
6"	WFP5306	WFP6306	WFP7306	WFP8306
8"	WFP5308	WFP6308	WFP7308	WFP8308
10"	WFP5310	WFP6310	WFP7310	WFP8310
12"	WFP5312	WFP6312	WFP7312	WFP8312
15"	WFP5315	WFP6315	WFP7315	WFP8315
18"	WFP5318	WFP6318	WFP7318	WFP8318
24"	WFP5324	WFP6324	WFP7324	WFP8324

Front Wall Filler Scribes - 18" Deep



- The Wall Filler Scribe is used to close a space between a wall cabinet and a wall. It can be cut to fit gaps of various sizes.
- A double angle is provided to enclose the raw edge of the panel.
- Filler panels can be ordered in 1" increments, up to 24" wide. Change the last two digits to the dimension required.
- Use option code "OL" when ordering Architectural Overlay design.

Width	24" High	30" High	36" High	48" High
1"	WFS5201	WFS6201	WFS7201	WFS8201
2"	WFS5202	WFS6202	WFS7202	WFS8202
3"	WFS5203	WFS6203	WFS7203	WFS8203
4"	WFS5204	WFS6204	WFS7204	WFS8204
6"	WFS5206	WFS6206	WFS7206	WFS8206
8"	WFS5208	WFS6208	WFS7208	WFS8208
10"	WFS5210	WFS6210	WFS7210	WFS8210
12"	WFS5212	WFS6212	WFS7212	WFS8212
15"	WFS5215	WFS6215	WFS7215	WFS8215
18"	WFS5218	WFS6218	WFS7218	WFS8218
24"	WFS5224	WFS6224	WFS7224	WFS8224

Front Wall Fillers - 18" Deep

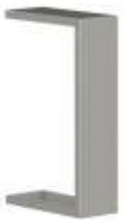

- The Wall Filler Scribe is used to close a space between two wall cabinets.
- Filler panels can be ordered in 1" increments, up to 24" wide. Change the last two digits to the dimension required.
- Use option code "OL" when ordering Architectural Overlay design.

Width	24" High	30" High	36" High	48" High
1"	WFP5201	WFP6201	WFP7201	WFP8201
2"	WFP5202	WFP6202	WFP7202	WFP8202
3"	WFP5203	WFP6203	WFP7203	WFP8203
4"	WFP5204	WFP6204	WFP7204	WFP8204
6"	WFP5206	WFP6206	WFP7206	WFP8206
8"	WFP5208	WFP6208	WFP7208	WFP8208
10"	WFP5210	WFP6210	WFP7210	WFP8210
12"	WFP5212	WFP6212	WFP7212	WFP8212
15"	WFP5215	WFP6215	WFP7215	WFP8215
18"	WFP5218	WFP6218	WFP7218	WFP8218
24"	WFP5224	WFP6224	WFP7224	WFP8224

MISCELLANEOUS ITEMS

Sloping Dust Caps

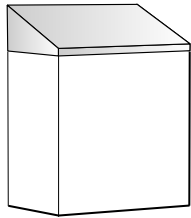

- The Sloping Dust Caps are used as a housekeeping aid on top of wall and floor cabinets.
- 8-3/8" high.

Width	14" Deep	18" Deep	22" Deep
15"	SDC0315	SDC0215	SDC0115
18"	SDC0318	SDC0218	SDC0118
24"	SDC0324	SDC0224	SDC0124
30"	SDC0330	SDC0230	SDC0130
36"	SDC0336	SDC0236	SDC0136
42"	SDC0342	SDC0242	SDC0142
48"	SDC0348	SDC0248	SDC0148
60"	SDC0360	SDC0260	SDC0160
72"	SDC0372	SDC0272	SDC0172
513mm	SDC030A	SDC020A	SDC010A
1000mm	SDC030B	SDC020B	SDC010B

Overlay Corner Dust Caps

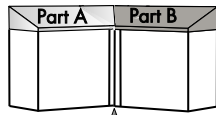

Front Wall Fillers

- The Overlay Corner Dust Caps are designed to close the corner space left by two wall cabinets. They are used in conjunction with a Sloping Dust Cap.
- 8-3/8" high.

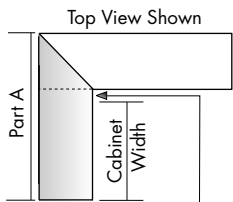

Top View Shown

Part A

Cabinet Width

- Order Overlay Corner Dust Cap based on cabinet width. Extra long sloping dust cap required see below to order.
- Cabinets must be equal depth.
- Order Front Wall Filler (WFP or WFS) in conjunction with an Overlay Corner Dust Cap.

1" Front Wall Filler (WFS or WFP)*

- When ordering Overlay Corner Dust Caps, always use left hand (Part A) side to be the corner overlaying dust cap.

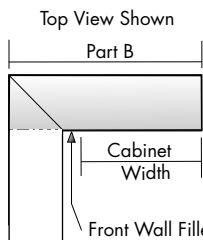

Top View Shown

Part B

Cabinet Width

Front Wall Filler (WFS or WFP)

- Order Overlay Corner Dust Cap based on cabinet width. Extra long Sloping Dust Cap required.

Part A Cabinet Width	14" Deep	18" Deep	22" Deep
15"	CDL0315	CDL0215	CDL0115
18"	CDL0318	CDL0218	CDL0118
24"	CDL0324	CDL0224	CDL0124
30"	CDL0330	CDL0230	CDL0130
36"	CDL0336	CDL0236	CDL0136
42"	CDL0342	CDL0242	CDL0142
48"	CDL0348	CDL0248	CDL0148
60"	CDL0360	CDL0260	CDL0160
72"	CDL0372	CDL0272	CDL0172
513mm	CDL030A	CDL020A	CDL010A
1000mm	CDL030B	CDL020B	CDL010B

Part B Cabinet Width	14" Deep	18" Deep	22" Deep
15"	CDR0315	CDR0215	CDR0115
18"	CDR0318	CDR0218	CDR0118
24"	CDR0324	CDR0224	CDR0124
30"	CDR0330	CDR0230	CDR0130
36"	CDR0336	CDR0236	CDR0136
42"	CDR0342	CDR0242	CDR0142
48"	CDR0348	CDR0248	CDR0148
60"	CDR0360	CDR0260	CDR0160
72"	CDR0372	CDR0272	CDR0172
513mm	CDR030A	CDR020A	CDR010A
1000mm	CDR030B	CDR020B	CDR010B

Corner Wall Cabinet Dust Caps

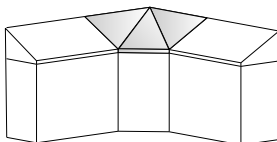

Depth	Item Number
14"	CDC0300
18"	CDC0200

- The Corner Wall Cabinet Dust Caps are used as a housekeeping aid on top of Corner Wall Cabinets.
- 8-3/8" high.

Sloping Dust Cap Scribes



- The scribe feature allows for easy width adjustment in the field.
- 8-3/8" high.
- Sloping Dust Caps comes with two ECS clips.
- Right hand shown.

Width	Right Hand			Left Hand		
	14"Depth	18"Depth	22"Depth	14"Depth	18"Depth	22"Depth
1"	SDR0301	SDR0201	SDR0101	SDL0301	SDL0201	SDL0101
2"	SDR0302	SDR0202	SDR0102	SDL0302	SDL0202	SDL0102
3"	SDR0303	SDR0203	SDR0103	SDL0303	SDL0203	SDL0103
4"	SDR0304	SDR0204	SDR0104	SDL0304	SDL0204	SDL0104
5"	SDR0305	SDR0205	SDR0105	SDL0305	SDL0205	SDL0105

MISCELLANEOUS ITEMS

Light Valances



- Left side return light valance shown. Right side return light valance is opposite of what is shown.
- 3" high.

Width	Right Side Return		Left Hand Return	
	12"Depth	16"Depth	12"Depth	16"Depth
18"	VPR3018	VPR4018	VPL3018	VPL4018
24"	VPR3024	VPR4024	VPL3024	VPL4024
30"	VPR3030	VPR4030	VPL3030	VPL4030
36"	VPR3036	VPR4036	VPL3036	VPL4036
42"	VPR3042	VPR4042	VPL3042	VPL4042
48"	VPR3048	VPR4048	VPL3048	VPL4048
60"	VPR3060	VPR4060	VPL3060	VPL4060
72"	VPR3072	VPR4072	VPL3072	VPL4072
96"	VPR3096	VPR4096	VPL3096	VPL4096



- Light valance to be fastened to the bottom of a wall cabinet. Available with left side, right side, or both returns.
- Use 12" deep light valance for 14" deep cabinets.
- Use 16" deep light valance for 18" deep cabinets.
- Light valance returns are 2" shorter in depth than the standard depth of the cabinet, to allow for clearance of opening and closing the doors above.
- 3" high.

Width	With Side Returns	
	12"Depth	16"Depth
18"	VPS3018	VPS4018
24"	VPS3024	VPS4024
30"	VPS3030	VPS4030
36"	VPS3036	VPS4036
42"	VPS3042	VPS4042
48"	VPS3048	VPS4048
60"	VPS3060	VPS4060
72"	VPS3072	VPS4072
96"	VPS3096	VPS4096



- Front only light valance to be fastened to the bottom of a wall cabinet.
- 3" high.

Width	Front Only
18"	VPF1018
24"	VPF1024
30"	VPF1030
36"	VPF1036
42"	VPF1042
48"	VPF1048
60"	VPF1060
72"	VPF1072
96"	VPF1096

Wall Cabinet Furring Panels



- Wall Cabinet Furring panels are used to close off the area between the top of a wall cabinet and the ceiling.
- Furring panels have a double scribe angle at top and a 2" wide flange at bottom.
- 24" high.

Width	14" Deep	18" Deep	22" Deep
18"	FPS1018	FPS2018	FPS3018
24"	FPS1024	FPS2024	FPS3024
30"	FPS1030	FPS2030	FPS3030
36"	FPS1036	FPS2036	FPS3036
42"	FPS1042	FPS2042	FPS3042
48"	FPS1048	FPS2048	FPS3048
60"	FPS1060	FPS2060	FPS3060
72"	FPS1072	FPS2072	FPS3072
96"	FPS1096	FPS2096	FPS3096
1000mm	FPS100B	FPS200B	FPS300B

MISCELLANEOUS ITEMS

Apron Units - 22" Deep



- Aprons provide a work area from a seated position.
- Aprons are available with or without drawers.
- 15" wide drawer.
- 3-3/4" high, three piece adjustable construction.
- Use option code "OL" when ordering Architectural Overlay design.

Width	Plain Front	With Drawers	# of Drawers
24"	AUC0124	AUA0124	1
30"	AUC0130	AUA0130	1
36"	AUC0136	AUA0136	1
42"	AUC0142	AUA0142	1
48"	AUC0148	AUA0148	2
54"	AUC0154	AUA0154	2
60"	AUC0160	AUA0160	2
66"	AUC0166	AUA0166	2
72"	AUC0172	AUA0172	2
513mm	AUC010A	AUA010A	1
1000mm	AUC010B	AUA010B	1

Apron Units 28" Deep



- Aprons provide a work area from a seated position.
- Aprons are available with or without drawers.
- 15" wide drawer.
- 3-3/4" high, three piece adjustable construction.
- Use option code "OL" when ordering Architectural Overlay design.

Width	Plain Front	With Drawers	# of Drawers
24"	AUC0424	AUA0424	1
30"	AUC0430	AUA0430	1
36"	AUC0436	AUA0436	1
42"	AUC0442	AUA0442	1
48"	AUC0448	AUA0448	2
54"	AUC0454	AUA0454	2
60"	AUC0460	AUA0460	2
66"	AUC0466	AUA0466	2
72"	AUC0472	AUA0472	2
513mm	AUC040A	AUA040A	1
1000mm	AUC040B	AUA040B	1

Welded Box Aprons - 22" Deep



- Aprons provide a work area from a seated position.
- Aprons are available with or without drawers.
- 15" wide drawer.
- 3-3/4" high, one piece welded construction.
- Use option code "OL" when ordering Architectural Overlay design.

Width	Plain Front	With Drawers	# of Drawers
24"	BUC0124	BUA0124	1
30"	BUC0130	BUA0130	1
36"	BUC0136	BUA0136	1
42"	BUC0142	BUA0142	1
48"	BUC0148	BUA0148	2
54"	BUC0154	BUA0154	2
60"	BUC0160	BUA0160	2
66"	BUC0166	BUA0166	2
72"	BUC0172	BUA0172	2
513mm	BUC010A	BUA010A	1
1000mm	BUC010B	BUA010B	1

Welded Box Aprons - 28" Deep



- Aprons provide a work area from a seated position.
- Aprons are available with or without drawers.
- 15" wide drawer.
- 3-3/4" high, one piece welded construction.
- Use option code "OL" when ordering Architectural Overlay design.

Width	Plain Front	With Drawers	# of Drawers
24"	BUC0424	BUA0424	1
30"	BUC0430	BUA0430	1
36"	BUC0436	BUA0436	1
42"	BUC0442	BUA0442	1
48"	BUC0448	BUA0448	2
54"	BUC0454	BUA0454	2
60"	BUC0460	BUA0460	2
66"	BUC0466	BUA0466	2
72"	BUC0472	BUA0472	2
513mm	BUC040A	BUA040A	1
1000mm	BUC040B	BUA040B	1

MISCELLANEOUS ITEMS

Apron Service Covers



- Apron Service Cover panels are used to conceal open spaces and services below aprons.
- Attaches to adjacent cabinets and meets the bottom of the apron.
- Assembly includes single angles for attachment to adjacent cabinets. Upper panel is removable to allow access to the services. The lower panel stays fixed in order to apply the coved base and overlapping the lower and upper panel allows to accommodate for uneven floors.

Width	Standing Ht.	Sitting Ht.	ADA Ht.
15"	SCP3015	SCP4015	SCP6015
18"	SCP3018	SCP4018	SCP6018
24"	SCP3024	SCP4024	SCP6024
30"	SCP3030	SCP4030	SCP6030
36"	SCP3036	SCP4036	SCP6036
42"	SCP3042	SCP4042	SCP6042
48"	SCP3048	SCP4048	SCP6048
54"	SCP3054	SCP4054	SCP6054
60"	SCP3060	SCP4060	SCP6060
66"	SCP3066	SCP4066	SCP6066
72"	SCP3072	SCP4072	SCP6072
513mm	SCP300A	SCP400A	SCP600A
1000mm	SCP300B	SCP400B	SCP600B

Front Rails



• 3-3/4" high



• 2" high

- Front Rails are commonly used to finish a space at a sitting area. They are used when a full frame apron is not required.
- In a "cut to fit" condition, use part number DAG000F for slip filler.

Width	3-3/4" High	2" High
18"	FRA0018	FRB0018
24"	FRA0024	FRB0024
30"	FRA0030	FRB0030
36"	FRA0036	FRB0036
42"	FRA0042	FRB0042
48"	FRA0048	FRB0048
54"	FRA0054	FRB0054
60"	FRA0060	FRB0060
66"	FRA0066	FRB0066
72"	FRA0072	FRB0072
513mm	FRA000A	FRB000A
1000mm	FRA000B	FRB000B

Double Angle Sleeves



Length	Item Number
3-3/4"	DAG000F
3"	DAG0003
2"	DAG0002

- Double Angle Sleeves are used to cover the cut edge of a "cut to fit" front rail.

Front Rail Service Covers



- Front Rail Service Cover panels are used to conceal open spaces and services behind front rails.
- Attaches to adjacent cabinets and meets the bottom of the work surface.
- Assembly includes single angles for attachment to adjacent cabinets. Upper panel is removable to allow access to the services. The lower panel stays fixed in order to apply the coved base and overlapping the lower and upper panel allows to accommodate for uneven floors.

Width	Standing Ht.	Sitting Ht.	ADA Ht.
15"	SCP1015	SCP2015	SCP5015
18"	SCP1018	SCP2018	SCP5018
24"	SCP1024	SCP2024	SCP5024
30"	SCP1030	SCP2030	SCP5030
36"	SCP1036	SCP2036	SCP5036
42"	SCP1042	SCP2042	SCP5042
48"	SCP1048	SCP2048	SCP5048
54"	SCP1054	SCP2054	SCP5054
60"	SCP1060	SCP2060	SCP5060
66"	SCP1066	SCP2066	SCP5066
72"	SCP1072	SCP2072	SCP5072
513mm	SCP100A	SCP200A	SCP500A
1000mm	SCP100B	SCP200B	SCP500B

All dimensions and sizes shown are nominal. Specifications and details are based on product information at the time of printing and may change at any time without notice. Mott Manufacturing reserves the right to change dimensions, specifications and manufacturing details at any time without notice.

MISCELLANEOUS ITEMS

Box Turret Supports

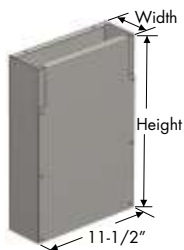

- Box Turret Supports are used to support reagent shelves. They may be used with front rails to form a rigid reagent support structure.
- The side panel is removable in order to access services.
- Counter top mounting clips are included.
- 11-1/2" deep.

Height	2" Wide	4" Wide	6" Wide
11"	9900062	9900010	9900012
17"	9900063	9900011	9900013

- Notched for a 3-3/4" high FRA rail.

Height	2" Wide	4" Wide	6" Wide
11"	9990062	9990010	9990012
17"	9990063	9990011	9990013

- Notched for a 2" high FRB rail.

Fixed Box Turret Support

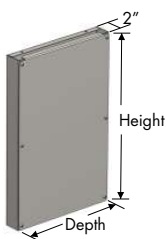

- Fixed Box Turret Supports are used to support reagent shelves. It may be used in conjunction with front rails to form a rigid reagent support structure.
- 2" wide.

Height	10" Deep	12" Deep	14" Deep	18" Deep
11"	BRS1010	BRS1012	BRS1014	BRS1018
14"	BRS2010	BRS2012	BRS2014	BRS2018
17"	BRS3010	BRS3012	BRS3014	BRS3018

Reagent Turret Supports

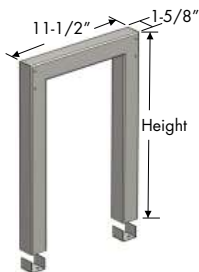

- Reagent Turret Supports are used to support reagent shelves.
- Stainless steel countertop mounting clips are included.
- 1-5/8" wide by 11-1/2" deep.

Height	Item Number
11"	9900006
17"	9900007
18"	9900008
19"	9900009

Adjustable Box Turret Supports

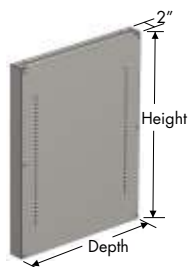

- Adjustable Box Turret End Supports are used to support reagent shelves. It may be used in conjunction with front rails to form a rigid reagent support structure.
- Adjustable slots are provided on one side.
- 2" wide.

Adjustable Box Turret End Supports				
Height	10" Deep	12" Deep	14" Deep	18" Deep
24"	BRE1010	BRE1012	BRE1014	BRE1018
34"	BRE2010	BRE2012	BRE2014	BRE2018

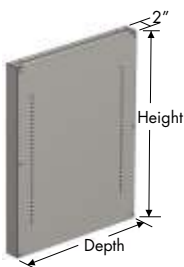

- Adjustable Box Turret Middle Supports are used to support reagent shelves. It may be used in conjunction with front rails to form a rigid reagent support structure.
- Adjustable slots are provided on both sides.
- 2" wide.

Adjustable Box Turret Middle Supports				
Height	10" Deep	12" Deep	14" Deep	18" Deep
24"	BRM1010	BRM1012	BRM1014	BRM1018
34"	BRM2010	BRM2012	BRM2014	BRM2018

MISCELLANEOUS ITEMS
Support Legs

- Support Legs are used to support island counter tops or aprons where base cabinets are not required.
- 1-1/2" wide.
- Use option code "OL" when ordering Architectural Overlay design.

Depth	Standing Ht.	Sitting Ht.	ADA Ht.
28"	GLD1028	GLD2028	GLD3028
29"	GLD1029	GLD2029	GLD3029
34"	GLD1034	GLD2034	GLD3034
35"	GLD1035	GLD2035	GLD3035
46"	GLD1046	GLD2046	GLD3046
52"	GLD1052	GLD2052	GLD3052
58"	GLD1058	GLD2058	GLD3058

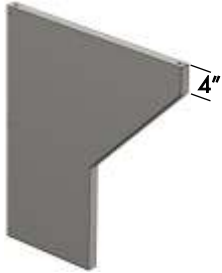

- Support Legs are used to support wall counter tops or aprons where base cabinets are not required.
- Lower portion depth is half of overall depth.
- Support Legs come complete with wall mounting channel.
- 1-1/2" wide.
- Use option code "OL" when ordering Architectural Overlay design.

Depth	Standing Ht.	Sitting Ht.	ADA Ht.
22"	GLA1022	GLA2022	GLA3022
23"	GLA1023	GLA2023	GLA3023
29"	GLA1029	GLA2029	GLA3029
35"	GLA1035	GLA2035	GLA3035

Gable Legs

- Gable Legs are used to support wall counter tops or aprons where base cabinets are not required.
- Gable Legs come complete with wall mounting channel.
- 1-1/2" wide.
- Use option code "OL" when ordering Architectural Overlay design.

Depth	Standing Ht.	Sitting Ht.	ADA Ht.
22"	GLS1022	GLS2022	GLS3022
23"	GLS1023	GLS2023	GLS3023
29"	GLS1029	GLS2029	GLS3029
35"	GLS1035	GLS2035	GLS3035

Support Legs

- Support Legs are used to support counter tops where base cabinets are not required.
- Leveling bolts and PVC boots are included.
- 2" X 2" tube.
- Suitable for use with TAC, TAA, TCC, TAB, TCB & TCE Tables.

Table Leg Assembly			
Depth	Standing Ht.	Sitting Ht.	ADA Ht.
22"	TLA1022	TLA2022	TLA5022
23"	TLA1023	TLA2023	TLA5023
28"	TLA1028	TLA2028	TLA5028
29"	TLA1029	TLA2029	TLA5029
35"	TLA1035	TLA2035	TLA5035



Double Table Leg Assembly			
Depth	Standing Ht.	Sitting Ht.	ADA Ht.
46"	TLA1046	TLA2046	TLA5046
52"	TLA1052	TLA2052	TLA5052
58"	TLA1058	TLA2058	TLA5058

MISCELLANEOUS ITEMS

Table Legs



Height	Item Number
28-3/4"	3200000
34-3/4"	3100000
31-3/4"	3500000

- Table Legs are used to support counter tops where base cabinets are not required.
- Leveling bolts and PVC boots are included.
- 2" x 2' tube.

Service Legs



Depth	Standing Ht.	Sitting Ht.	ADA Ht.
7"	SLG1007	SLG2007	SLG3007
11"	SLG1011	SLG2011	SLG3011
14"	SLG1014	SLG2014	SLG3014

- Service Legs are used to go behind cabinets when extra counter support is required.
- Service Legs can also be used by plumbers to attach piping within the service chase.
- Each assembly comes with 3/8" spring nuts & bolts.

Under Counter Support Brackets

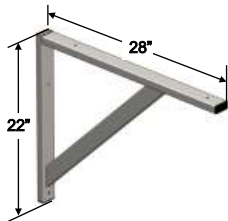

Item Number

CBS0001

- Under Counter Support Brackets are used to support counter tops.
- Suitable for 30" counter tops.
- Supports are 22" high by 28" deep welded from 1" x 2" 16 gauge steel tube.

Stainless Steel Electrical Pedestal Boxes



Single

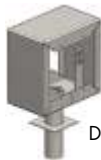

Double

Single Gang	Double Gang
-------------	-------------

PBS

PBD

- Double-faced deck-mounted stainless steel outlet box only.
- Complete with threaded nipple to attach to mounting surface.
- Cover plate and receptacles are not included.
- Not CSA or UL approved.

MISCELLANEOUS ITEMS

Full Access Island Service Drops

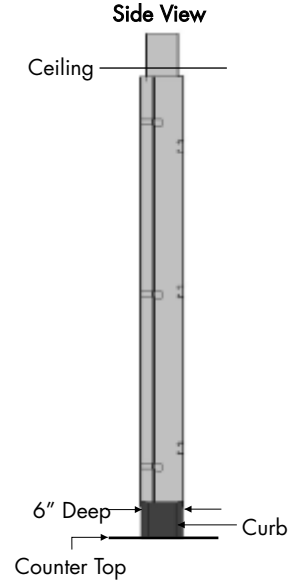
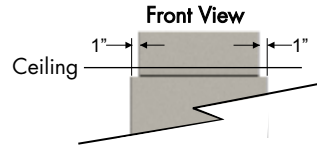
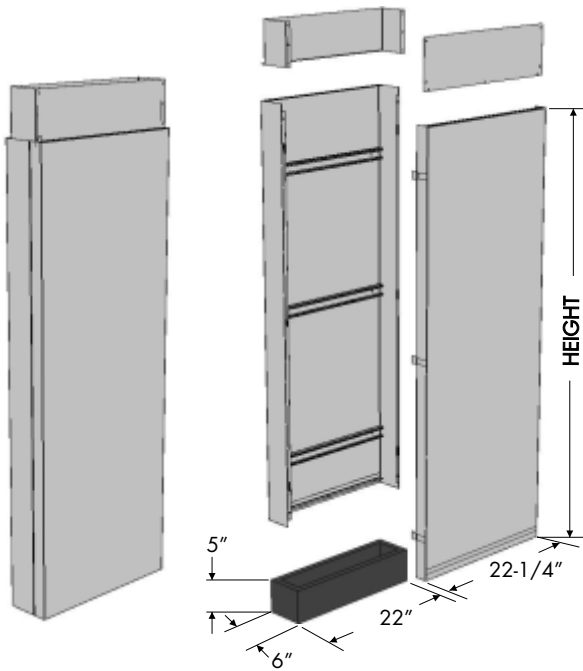

Height	Item Number
68"	SDP1368
73"	SDP1373
78"	SDP1378
90"	SDP1390

- Use to carry utilities from the counter top up through the ceiling.
- Service Drop offers full height (from counter top to ceiling) access to services.
- Front panel attaches with 'Z' clip.
- Designed to fit on a 22" wide x 5" high x 6" deep curb.

Full Access Wall Service Drops

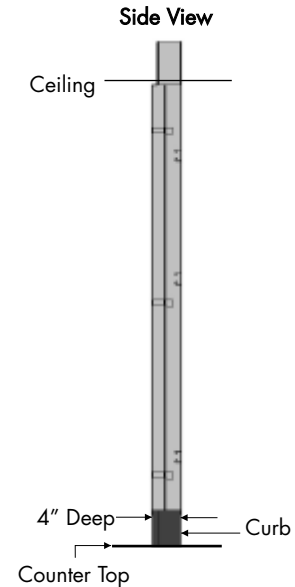
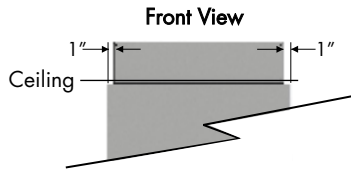
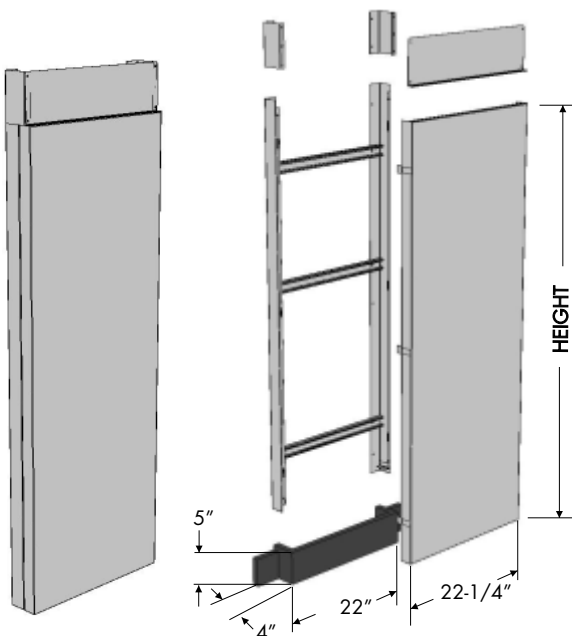

Height	Item Number
68"	SDP1468
73"	SDP1473
78"	SDP1478
90"	SDP1490

- Use to carry utilities from the counter top up through the ceiling.
- Service Drop offers full height (from counter top to ceiling) access to services.
- Front panel attaches with 'Z' clip.
- Designed to fit on a 22" wide x 5" high x 4" deep curb.

MISCELLANEOUS ITEMS

Service Drops

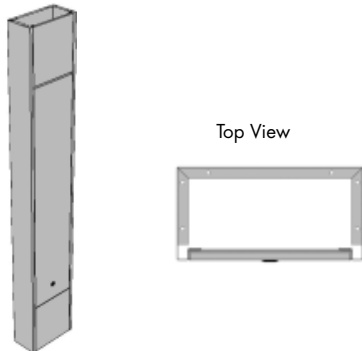

Height	6" Deep		8" Deep	
	12"Width	24"Width	12"Width	24"Width
78"	SDP3078	SDP4078	SDP1078	SDP2078
90"	SDP3090	SDP4090	SDP1090	SDP2090

- Use to carry utilities from the counter top up through the ceiling, for wall and island applications.
- Each assembly consists of two 12" high fixed upper and lower panels and a lift off center panel.
- 78" high service drop has 54" center lift off panel.
- 90" high service drop has 66" center lift off panel.

Radius Island Service Drops

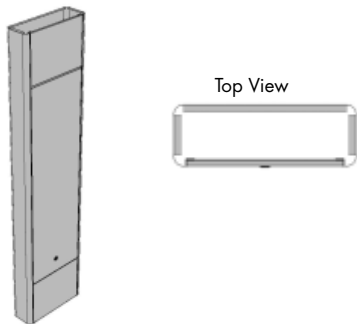

Height	12"Width	24"Width
78"	SDP1178	SDP2178
90"	SDP1190	SDP2190

- Use to carry utilities from the counter top up through the ceiling, for island applications.
- Each assembly consists of two 12" high fixed upper and lower panels and a lift off center panel.
- 78" high service drop has 54" center lift off panel.
- 90" high service drop has 66" center lift off panel.
- 6" deep (maximum depth available).

Radius Wall Service Drops

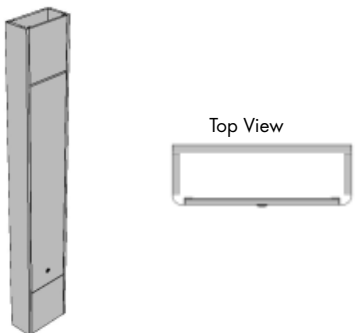

Height	12"Width	24"Width
78"	SDP1278	SDP2278
90"	SDP1290	SDP2290

- Use to carry utilities from the counter top up through the ceiling, for wall applications.
- Each assembly consists of two 12" high fixed upper and lower panels and a lift off center panel.
- 78" high service drop has 54" center lift off panel.
- 90" high service drop has 66" center lift off panel.
- 6" deep (maximum depth available).

Service Drop Ceiling Trims



Depth	12"Width	24"Width
6"	EDC1006	EDC2006
8"	EDC1000	EDC2000

- Not for use with Radius and Full access Service Drops.
- Required when Service Drop extends past the ceiling tile.
- Suitable for a 6" and 8" deep Service Drop.

MISCELLANEOUS ITEMS

Cylinder Storage Racks



2 cylinder rack shown

Width	Item Number	Capable of Holding
16"	CSR1116	1 Cylinder
30"	CSR1230	2 Cylinders
44"	CSR1344	3 Cylinders
58"	CSR1458	4 Cylinders
72"	CSR1572	5 Cylinders

- One cylinder deep storage rack.
- Holds up to 10" diameter cylinders.
- Welded steel rack 30"high x 16"deep.
- Secure to both walls and floor with 1/2" steel anchor bolts.
- Non-kink zinc plated chain.



4 cylinder rack shown

Width	Item Number	Capable of Holding
16"	CSR2116	2 Cylinder
30"	CSR2230	4 Cylinders
44"	CSR2344	6 Cylinders
58"	CSR2458	8 Cylinders
72"	CSR2572	10 Cylinders

- Two cylinder deep storage rack.
- Holds up to 10" diameter cylinders.
- Welded steel rack 30"high x 26"deep.
- Secure to both walls and floor with 1/2" steel anchor bolts.
- Non-kink zinc plated chain.



6 cylinder rack shown

Width	Item Number	Capable of Holding
16"	CSR3116	3 Cylinder
30"	CSR3230	6 Cylinders
44"	CSR3344	9 Cylinders
58"	CSR3458	12 Cylinders
72"	CSR3572	15 Cylinders

- Three cylinder deep storage rack.
- Holds up to 10" diameter cylinders.
- Welded steel rack 30"high x 38"deep.
- Secure to both walls and floor with 1/2" steel anchor bolts.
- Non-kink zinc plated chain.

MISCELLANEOUS ITEMS

Reagent Island Shelving Unit

Reagent Island Shelving Units are designed to provide support for shelving and are 1" wide by 2" deep. Units are available in custom lengths to suit your exact requirements.

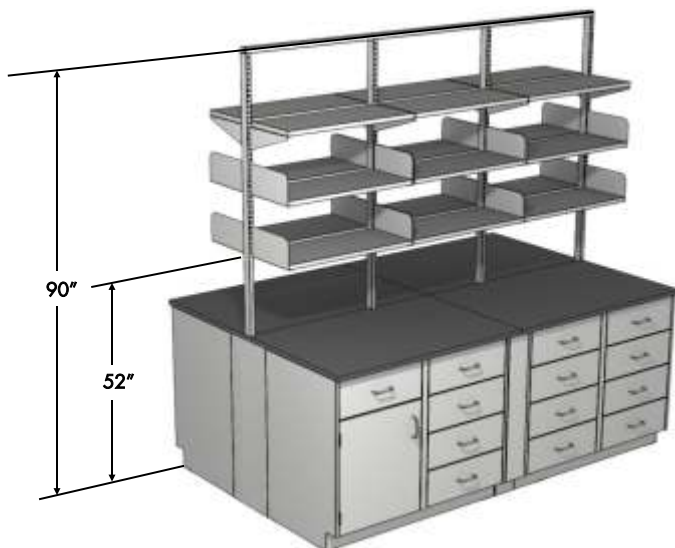

Reagent Uprights



Item Number

RIV0090

- Used to create island assemblies where upright shelving is needed and relies on adjacent fixed casework for support.
- Reagent Uprights are 90" high by 1" wide by 2" deep tubing and are supplied with base support and hardware.
- Uprights are double slotted on both sides allowing shelving to be adjustable in 1" increments.
- Reagent Uprights are only suitable with "RIB" Shelf Brackets.
- Reagent Uprights are not suitable for suspending cabinets or work surfaces.

Reagent Upper Rail



Item Number

RIH0120

- Used for island assemblies where upright shelving is needed and relies on adjacent fixed casework for support.
- Reagent Upper Rails are 1" high by 2" deep by 120" long tubing.
- Maximum length available without a seam in upper rail is 120" long.
- Available in custom lengths to suit your requirements.
- Supplied with two black plastic end caps.

Reagent Upper Rail Jointer

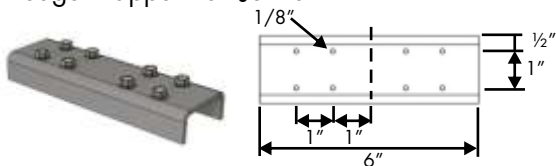

Item Number

RIJ0000

- Used for joining two Reagent Upper Rails together.
- Fits inside of 1" high by 2" deep tubing.
- Reagent Upper Rail Jointer is 6" long.
- Supplied with hardware.

MISCELLANEOUS ITEMS

Reagent Island Steel & Wood Shelves



- Shelves suitable for Reagent Island shelving units.
- Shelves are actual widths.

- Add 1" angles to shelves by using option codes:
 - AR (Rear Shelf Angle welded to shelf)
 - AF (Front Shelf Angle welded to shelf)
 - AB (Rear and Front Shelf Angle welded to shelf)



- Shelves suitable for Reagent Island shelving units.
- Shelves are actual widths.
- For wood shelving options see page N8.

Steel Shelves					
Width	10"Deep	12"Deep	14"Deep	16"Deep	18" Deep
24"	RIS1024	RIS1224	RIS1424	RIS1624	RIS1824
30"	RIS1030	RIS1230	RIS1430	RIS1630	RIS1830
36"	RIS1036	RIS1236	RIS1436	RIS1636	RIS1836
42"	RIS1042	RIS1242	RIS1442	RIS1642	RIS1842
48"	RIS1048	RIS1248	RIS1448	RIS1648	RIS1848
60"	RIS1060	RIS1260	RIS1460	RIS1660	RIS1860

Wood Shelves					
Width	10"Deep	12"Deep	14"Deep	16"Deep	18" Deep
24"	RIS1024W	RIS1224W	RIS1424W	RIS1624W	RIS1824W
30"	RIS1030W	RIS1230W	RIS1430W	RIS1630W	RIS1830W
36"	RIS1036W	RIS1236W	RIS1436W	RIS1636W	RIS1836W
42"	RIS1042W	RIS1242W	RIS1442W	RIS1642W	RIS1842W
48"	RIS1048W	RIS1248W	RIS1448W	RIS1648W	RIS1848W
60"	RIS1060W	RIS1260W	RIS1460W	RIS1660W	RIS1860W

Reagent Island Shelf Brackets

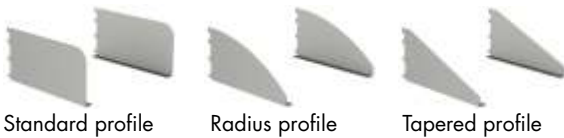

Standard profile Radius profile Tapered profile

Depth	Standard Profile	Radius Profile	Tapered Profile
10"	RIB0010	RIB3010	RIB4010
12"	RIB0012	RIB3012	RIB4012
14"	RIB0014	RIB3014	RIB4014
16"	RIB0016	RIB3016	RIB4016
18"	RIB0018	RIB3018	RIB4018

- Brackets only suitable for Reagent components.
- Pair of shelf brackets are 6" high.

Reagent Island Inverted Shelf Brackets



Tapered profile



Radius profile

Depth	Tapered Profile	Radius Profile
10"	RIB1010	RIB1110
12"	RIB1012	RIB1112
14"	RIB1014	RIB1114
16"	RIB1016	RIB1116
18"	RIB1018	RIB1118

- Brackets only suitable for Reagent components.
- Pair of shelf brackets are 4-1/4" high.

Reagent Island Shelf Angles



- Shelf angles are only suitable for steel RIS shelves.
- 2" high with a 1" return and notched for shelf brackets.

Length	Item Number
20"	RSA2120
24"	RSA2124
30"	RSA2130
36"	RSA2136
42"	RSA2142
48"	RSA2148
60"	RSA2160

Reagent Island Shelf Retainer Rods



≤ 30" wide assemblies



> 30" wide assemblies

Width	Steel Shelves		Wood Shelves		Retainer Rod Parts
	Powder Coated	Stainless Steel	Powder Coated	Stainless Steel	
24"	PRR0024-MI	SRRO024-MI	PRR0024-MIW	SRRO024-MIW	1 rod & 2 turrets
30"	PRR0030-MI	SRRO030-MI	PRR0030-MIW	SRRO030-MIW	1 rod & 2 turrets
36"	PRR0036-MI	SRRO036-MI	PRR0036-MIW	SRRO036-MIW	1 rod & 3 turrets
42"	PRR0042-MI	SRRO042-MI	PRR0042-MIW	SRRO042-MIW	1 rod & 3 turrets
48"	PRR0048-MI	SRRO048-MI	PRR0048-MIW	SRRO048-MIW	1 rod & 3 turrets
60"	PRR0060-MI	SRRO060-MI	PRR0060-MIW	SRRO060-MIW	1 rod & 3 turrets

- 1" high retainer rod (5/16" dia.) Prevents articles from falling off the shelf.
- Available in stainless steel or powder coated stainless steel and can be added to existing shelves. Ships loose.
- Threaded turrets includes hardware for mounting to shelf (shelf must have holes drilled to accept turrets).
- MI and MIW at the end of the part numbers represent option codes.

MISCELLANEOUS ITEMS

Sigma Flex™ Wall Pilasters

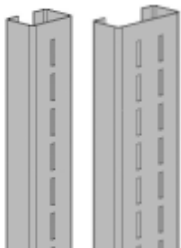

- Single Slotted Pilasters are 13/16" deep by 1-1/4" wide.
- Double Slotted Pilasters are 13/16" deep by 2-1/2" wide.
- Pilasters are adjustable in 1" increments. Accepts Sigma Flex™ shelves.
- Fastens to wall to give support structure where no services are required.
- Ensure wall is of sufficient strength to support intended load (significant blocking required).

Height	Single Sided	Double Sided
18"	FPA01018	FPA0018
24"	FPA1024	FPA0024
30"	FPA1030	FPA0030
36"	FPA1036	FPA0036
42"	FPA1042	FPA0042
48"	FPA1048	FPA0048
60"	FPA1060	FPA0060
72"	FPA1072	FPA0072
96"	FPA1096	FPA0096

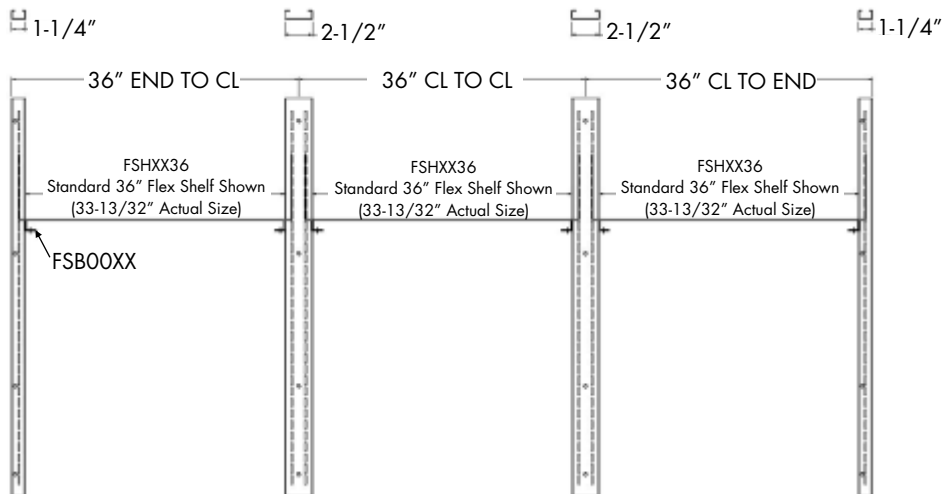

Sigma Flex™ Shelves



- Shelves suitable for Sigma Flex™ support structure or Sigma Cart™.
- Attach to shelf brackets with screws (screws not included).
- Nominal width.
- For wood shelving options see page N8.
- Add option code EW for exact width.



Steel Shelves						
Width	6" Deep	8" Deep	10" Deep	12" Deep	14" Deep	18" Deep
24"	FSH0624	FSH0824	FSH1024	FSH1224	FSH1424	FSH1824
30"	FSH0630	FSH0830	FSH1030	FSH1230	FSH1430	FSH1830
36"	FSH0636	FSH0836	FSH1036	FSH1236	FSH1436	FSH1836
42"	FSH0642	FSH0842	FSH1042	FSH1242	FSH1442	FSH1842
48"	FSH0648	FSH0848	FSH1048	FSH1248	FSH1448	FSH1848
54"	FSH0654	FSH0854	FSH1054	FSH1254	FSH1454	FSH1854
60"	FSH0660	FSH0860	FSH1060	FSH1260	FSH1460	FSH1860
66"	FSH0666	FSH0866	FSH1066	FSH1266	FSH1466	FSH1866
72"	FSH0672	FSH0872	FSH1072	FSH1272	FSH1472	FSH1872

Wood Shelves						
Width	6" Deep	8" Deep	10" Deep	12" Deep	14" Deep	18" Deep
24"	FSH0624W	FSH0824W	FSH1024W	FSH1224W	FSH1424W	FSH1824W
30"	FSH0630W	FSH0830W	FSH1030W	FSH1230W	FSH1430W	FSH1830W
36"	FSH0636W	FSH0836W	FSH1036W	FSH1236W	FSH1436W	FSH1836W
42"	FSH0642W	FSH0842W	FSH1042W	FSH1242W	FSH1442W	FSH1842W
48"	FSH0648W	FSH0848W	FSH1048W	FSH1248W	FSH1448W	FSH1848W
54"	FSH0654W	FSH0854W	FSH1054W	FSH1254W	FSH1454W	FSH1854W
60"	FSH0660W	FSH0860W	FSH1060W	FSH1260W	FSH1460W	FSH1860W

MISCELLANEOUS ITEMS

Sigma Flex™ Shelf Retainer Rods



<=30" wide assemblies



>30" wide assemblies

Width	Steel Shelves		Wood Shelves		Retainer Rod Parts
	Powder Coated	Stainless Steel	Powder Coated	Stainless Steel	
24"	PRR0024-FX	SRRO024-FX	PRR0024-FXW	SRRO024-FXW	1 rod & 2 turrets
30"	PRR0030-FX	SRRO030-FX	PRR0030-FXW	SRRO030-FXW	1 rod & 2 turrets
36"	PRR0036-FX	SRRO036-FX	PRR0036-FXW	SRRO036-FXW	1 rod & 3 turrets
42"	PRR0042-FX	SRRO042-FX	PRR0042-FXW	SRRO042-FXW	1 rod & 3 turrets
48"	PRR0048-FX	SRRO048-FX	PRR0048-FXW	SRRO048-FXW	1 rod & 3 turrets
54"	PRR0054-FX	SRRO054-FX	PRR0054-FXW	SRRO054-FXW	1 rod & 3 turrets
60"	PRR0060-FX	SRRO060-FX	PRR0060-FXW	SRRO060-FXW	1 rod & 3 turrets
66"	PRR0066-FX	SRRO066-FX	PRR0066-FXW	SRRO066-FXW	1 rod & 4 turrets
72"	PRR0072-FX	SRRO072-FX	-	-	1 rod & 4 turrets

- 1" high retainer rod (5/16" dia.) Prevents articles from falling off the shelf.
- Available in stainless steel or powder coated stainless steel and can be added to existing shelves.
- Threaded turrets includes hardware for mounting to shelf (shelf must have holes drilled to accept turrets).
- Ships loose.
- FX and FXW at the end of the part numbers represent option codes.

Sigma Flex™ Top Shelf Brackets



- Pair of top shelf brackets can be used for shelves of different materials.
- Adjustable in 1" increments.
- Only compatible with Sigma Flex™ or Sigma Cart™.

Depth	Item Number
6"	FIB0006
8"	FIB0008
10"	FIB0010
12"	FIB0012
14"	FIB0014
18"	FIB0018

Sigma Flex™ Lower Shelf Brackets



- Pair of lower shelf brackets can be used for shelves of different materials.
- Adjustable in 1" increments.
- Only compatible with Sigma Flex™ or Sigma Cart™.

Depth	Item Number
6"	FSB0006
8"	FSB0008
9"	FSB0009
10"	FSB0010
12"	FSB0012
14"	FSB0014
18"	FSB0018

Sigma Flex™ Radius Top Shelf Brackets



- Pair of radius shelf brackets can be used for shelves of different materials.
- Adjustable in 1" increments.
- Only compatible with Sigma Flex™ or Sigma Cart™.

Depth	Item Number
6"	FIB3006
8"	FIB3008
10"	FIB3010
12"	FIB3012
14"	FIB3014
18"	FIB3018

Sigma Flex™ Radius Outer Shelf Brackets



- Pair of radius outer shelf brackets can be used for shelves of different materials.
- Adjustable in 1" increments.
- Only compatible with Sigma Flex™ or Sigma Cart™.

Depth	Item Number
6"	FSB3006
8"	FSB3008
9"	FSB3009
10"	FSB3010
12"	FSB3012
14"	FSB3014
18"	FSB3018

Sigma Flex™ Tapered Top Shelf Brackets



- Pair of tapered shelf brackets can be used for shelves of different materials.
- Adjustable in 1" increments.
- Only compatible with Sigma Flex™ or Sigma Cart™.

Depth	Item Number
6"	FIB4006
8"	FIB4008
10"	FIB4010
12"	FIB4012
14"	FIB4014
18"	FIB4018

Sigma Flex™ Tapered Outer Shelf Brackets



- Pair of tapered outer shelf brackets can be used for shelves of different materials.
- Adjustable in 1" increments.
- Only compatible with Sigma Flex™ or Sigma Cart™.

Depth	Item Number
6"	FSB4006
8"	FSB4008
9"	FSB4009
10"	FSB4010
12"	FSB4012
14"	FSB4014
18"	FSB4018

MISCELLANEOUS ITEMS

Sigma Frame™ Wall Pilasters



- Pilasters only suitable for Sigma Frame™, Inverted Shelf Brackets, "SBP" and "WPA" components.
- 1-5/8" wide by 13/16" deep.
- Pilasters are adjustable in 1" increments.
- Fastens to wall to give support structure where no services are required.
- Ensure wall is of sufficient strength to support intended load (significant blocking required).

Height	Single Sided	Double Sided
18"	WPA1018	WPA0018
24"	WPA1024	WPA0024
30"	WPA1030	WPA0030
36"	WPA1036	WPA0036
42"	WPA1042	WPA0042
48"	WPA1048	WPA0048
60"	WPA1060	WPA0060
72"	WPA1072	WPA0072
96"	WPA1096	WPA0096

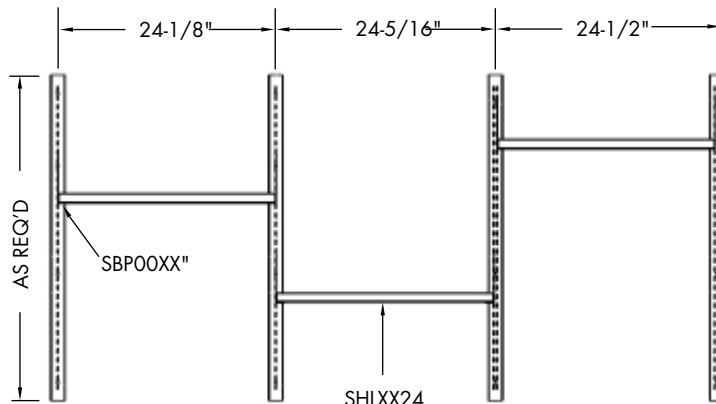

24" SHELF SIZE IS DIMENSIONED FROM PILASTER CENTER LINE
* 24" LONG SPACING EXAMPLE SHOWN

Sigma Frame™ Steel & Wood Shelves For Wall Pilasters



- Shelves are actual widths.
- Shelves suitable for Sigma Frame™.
- Add 1" angles to shelves by using option codes:
 - AR (Rear Shelf Angle welded to shelf)
 - AF (Front Shelf Angle welded to shelf)
 - AB (Rear and Front Shelf Angle welded to shelf)

Steel Shelves Width	10"Deep	12"Deep	14"Deep	16"Deep	18" Deep
24"	SHL1024	SHL1224	SHL1424	SHL1624	SHL1824
30"	SHL1030	SHL1230	SHL1430	SHL1630	SHL1830
36"	SHL1036	SHL1236	SHL1436	SHL1636	SHL1836
42"	SHL1042	SHL1242	SHL1442	SHL1642	SHL1842
48"	SHL1048	SHL1248	SHL1448	SHL1648	SHL1848
60"	SHL1060	SHL1260	SHL1460	SHL1660	SHL1860
513mm	SHL100A	SHL120A	SHL140A	SHL160A	SHL180A
1000mm	SHL100B	SHL120B	SHL140B	SHL160B	SHL180B
1512mm	SHL100C	SHL120C	SHL140C	SHL160C	SHL180C
2000mm	SHL100D	SHL120D	SHL140D	SHL160D	SHL180D



- Shelves are actual widths.
- Shelves suitable for Sigma Frame™.
- Shelves are 1" thick.
- For wood shelving options see page N8.

Wood Shelves Width	10"Deep	12"Deep	14"Deep	16"Deep	18" Deep
24"	SHL1024W	SHL1224W	SHL1424W	SHL1624W	SHL1824W
30"	SHL1030W	SHL1230W	SHL1430W	SHL1630W	SHL1830W
36"	SHL1036W	SHL1236W	SHL1436W	SHL1636W	SHL1836W
42"	SHL1042W	SHL1242W	SHL1442W	SHL1642W	SHL1842W
48"	SHL1048W	SHL1248W	SHL1448W	SHL1648W	SHL1848W
60"	SHL1060W	SHL1260W	SHL1460W	SHL1660W	SHL1860W
513mm	SHL100AW	SHL120AW	SHL140AW	SHL160AW	SHL180AW
1000mm	SHL100BW	SHL120BW	SHL140BW	SHL160BW	SHL180BW
1512mm	SHL100CW	SHL120CW	SHL140CW	SHL160CW	SHL180CW

MISCELLANEOUS ITEMS

Sigma Frame™ Shelf Retainer Rods

	Steel Shelves			Wood Shelves		Retainer Rod Parts
	Width	Powder Coated	Stainless Steel	Powder Coated	Stainless Steel	
 ≤ 30" wide assemblies	24"	PRR0024-MI	SRR0024-MI	PRR0024-MIW	SRR0024-MIW	1 rod & 2 turrets
	30"	PRR0030-MI	SRR0030-MI	PRR0030-MIW	SRR0030-MIW	1 rod & 2 turrets
	36"	PRR0036-MI	SRR0036-MI	PRR0036-MIW	SRR0036-MIW	1 rod & 3 turrets
 > 30" wide assemblies	42"	PRR0042-MI	SRR0042-MI	PRR0042-MIW	SRR0042-MIW	1 rod & 3 turrets
	48"	PRR0048-MI	SRR0048-MI	PRR0048-MIW	SRR0048-MIW	1 rod & 3 turrets
	60"	PRR0060-MI	SRR0060-MI	PRR0060-MIW	SRR0060-MIW	1 rod & 3 turrets
	513mm	PRR000A-MI	SRR000A-MI	PRR000A-MIW	SRR000A-MIW	1 rod & 2 turrets
	1000mm	PRR000B-MI	SRR000B-MI	PRR000B-MIW	SRR000B-MIW	1 rod & 3 turrets
	1512mm	PRR000C-MI	SRR000C-MI	PRR000C-MIW	SRR000C-MIW	1 rod & 3 turrets
2000mm	PRR000D-MI	SRR000D-MI	PRR000D-MIW	SRR000D-MIW	1 rod & 4 turrets	

- 1" high retainer rod (5/16" dia.) Prevents articles from falling off the shelf.
- Available in stainless steel or powder coated stainless steel and can be added to existing shelves.
- Threaded turrets includes hardware for mounting to shelf (shelf must have holes drilled to accept turrets).
- Ships loose.
- MI and MIW at the end of the part numbers represent option codes.

Sigma Frame™ Shelf Brackets For Wall Pilasters

	Depth	Standard Profile	Radius Profile	Tapered Profile
 Standard profile Radius profile Tapered profile	10"	SBP0010	SBP3010	SBP4010
	12"	SBP0012	SBP3012	SBP4012
	14"	SBP0014	SBP3014	SBP4014
	16"	SBP0016	SBP3016	SBP4016
	18"	SBP0018	SBP3018	SBP4018

- Brackets only suitable for Sigma Frame™ and "WPA" components.
- Pair of shelf brackets are 6" high.
- Add option code NN for no alignment tabs on SBP brackets.

Sigma Frame™ Inverted Shelf Brackets For Wall Pilasters

	Depth	Tapered Profile	Radius Profile
 Tapered profile Radius profile	10"	SBP1010	SBP1110
	12"	SBP1012	SBP1112
	14"	SBP1014	SBP1114
	16"	SBP1016	SBP1116
	18"	SBP1018	SBP1118

- Brackets only suitable for Reagent components.
- Pair of shelf brackets are 4-1/4" high.

Under Mount Shelf Task Lights

	Length of Light	Item Number
 <ul style="list-style-type: none"> • Order light a minimum 6" shorter than the shelf. • Low profile (.98" wide by 1.65" high) T5 fluorescent task light mounts to underside of the shelf. • Shatterproof polycarbonate lens protects the lamp. • Easily linkable in one continuous line using Flexible Connectors. 6" Flexible Connector comes standard with each light. See below to order longer Flexible Connectors. • On-off rocker switch located on the side of the fixture. • 8000 hour, cool white replaceable T5 lamp included. • UL listed. • Ships loose, includes Mott's mounting brackets. 	14"	TLW0014
	23"	TLW0023
	36"	TLW0036
	48"	TLW0048
	59"	TLW0059

Task Light Flexible Connectors

	Length	Item Number
 <ul style="list-style-type: none"> • Flexible Connector allows to easily link T5 fluorescent lights in one continuous line. • Ships loose. 	12"	LFC0012
	24"	LFC0024
	36"	LFC0036

MISCELLANEOUS ITEMS

PEGBOARDS

Epoxy Pegboards



- Black epoxy, 1" thick construction.
- Accepts 2" and 4" deep drip troughs. Must be ordered separately.
- Add option code "15" for finished back.
- 5" long, 3/8" diameter, white polypropylene pegs included. For black pegs use option code "PB" For gray pegs use option code "PG".

Phenolic Pegboards



- Black phenolic, 1" thick construction.
- Accepts 2" and 4" deep drip troughs. Must be ordered separately.
- 5" long, 3/8" diameter, white polypropylene pegs included. For black pegs use option code "PB" For gray pegs use option code "PG".

Stainless Steel Pegboards



- 20 gauge, type 304 stainless steel with #4 finish.
- Add option "ZR" for "Z" wall mounting rail.
- Provided with a 2" or 4" deep drip trough integral to the pegboard.
- Add option code "15" for stainless steel finished back.
- 5" long, 3/8" diameter, white polypropylene pegs included. For black pegs use option code "PB" For gray pegs use option code "PG".

Width & Height	Epoxy	Phenolic	Stainless Steel With 2" Deep Trough	Stainless Steel With 4" Deep Trough	Number Of Pegs
18" X 24"	EPB1824	PPB1824	SPC1824	SPB1824	23
22" X 30"	EPB2230	PPB2230	SPC2230	SPB2230	33
22" X 36"	EPB2236	PPB2236	SPC2236	SPB2236	39
24" X 30"	EPB2430	PPB2430	SPC2430	SPB2430	33
24" X 36"	EPB2436	PPB2436	SPC2436	SPB2436	39
30" X 36"	EPB3036	PPB3036	SPC3036	SPB3036	53
36" X 30"	EPB3630	PPB3630	SPC3630	SPB3630	51

Tube Pegs



Peg Color	5" Long
White	PEGW105
Black	PEGB105
Gray	PEGG105

- 5" long, 3/8" diameter.

Drip Troughs



Width	2" Deep	4" Deep
18"	DTC0218	DTC0418
22"	DTC0222	DTC0422
24"	DTC0224	DTC0424
30"	DTC0230	DTC0430
36"	DTC0236	DTC0436

- 2" and 4" deep drip troughs with 3/8" drain hole. 3 feet of clear PVC drain hose included.
- 20 gauge, type 304 stainless steel with a #4 finish.
- Mounts to the underside of pegboard.

Drain Screen Insert For Drip Troughs



Width	2" Deep	4" Deep
18"	DSIO218	DSIO418
22"	DSIO222	DSIO422
24"	DSIO224	DSIO424
30"	DSIO230	DSIO430
36"	DSIO236	DSIO436

- 2" and 4" deep drain screen inserts for drip troughs.
- 20 gauge, type 304 stainless steel with a #4 finish.

MISCELLANEOUS ITEMS

PEGBOARD ACCESSORIES

Pegboard Hanging Brackets For Sigma Flex™ Wall Pilasters



Item Number

BPB0000

- Pair of hanging brackets for pegboards, only compatible with Sigma Flex™ Wall Pilasters.
- Attaches with fasteners, mounting hardware included.
- Ships loose.

Sigma Flex™ Wall Pilasters

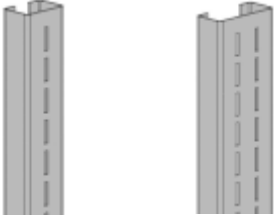

Height	Single Slotted	Double Slotted
18"	FPA1018	FPA0018
24"	FPA1024	FPA0024
30"	FPA1030	FPA0030
36"	FPA1036	FPA0036
42"	FPA1042	FPA0042
48"	FPA1048	FPA0048
60"	FPA1060	FPA0060
72"	FPA1072	FPA0072
96"	FPA1096	FPA0096

- Single Slotted Pilasters are 13/16" deep by 1-1/4" wide.
- Double Slotted Pilasters are 13/16" deep by 2-1/2" wide.
- Pilasters are adjustable in 1" increments.
- Fastens to wall to give support structure where no services are required.
- Ensure wall is of sufficient strength to support intended load (significant blocking required).

MISCELLANEOUS ITEMS

METAL FRAMING SYSTEM

Continuous Slot Metal Framing System

- Installs quickly
- Completely adjustable
- Re-usable
- Eliminates all welding, drilling and use of special tools



1. Place the spring nut anywhere along the continuous slotted channel.



2. Turn clockwise 90° to line up the grooves in the nut with the inturned edges of the channel.

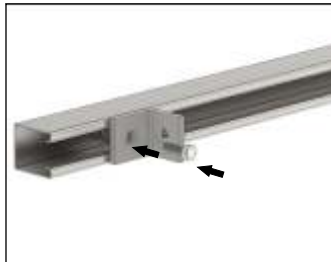

3. Inset the bolt through the fitting and into the spring nut.



4. Added channels are able to be bolted to the existing fitting by following procedure described in steps 1-3.

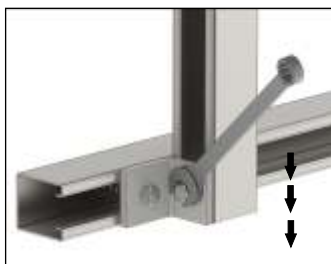

5. Using a wrench to tighten the bolt will lock the serrated teeth of the channel nut onto the inturned edges of the channel.

MISCELLANEOUS ITEMS

METAL FRAMING SYSTEM

1-5/8" x 1-5/8" Channel

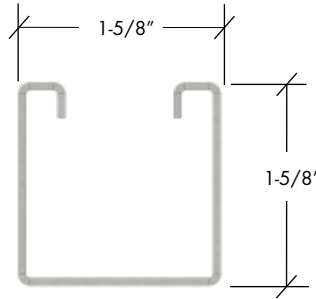

Channels are accurately and carefully cold rolled formed to size from low-carbon strip steel. Cold rolled and stainless steel are offered in 12 gauge.

1-5/8" x 13/16" Channel

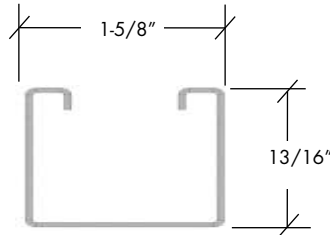

Channels are accurately and carefully cold rolled formed to size from low-carbon strip steel. Cold rolled and stainless steel are offered only 16 gauge.

Channel Details

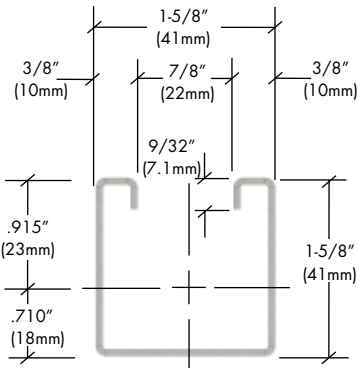

- Wt/100 Ft: 378 Lbs (281 kg/100m).
- Allowable Moment 5,070 In-Lbs (570 N*m).
- 12 gauge Nominal Thickness .105" (2.7mm).

Channels 1-5/8" x 1-5/8"

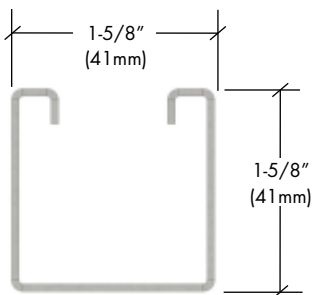

Length	12 Gauge
24"	SMF1224
48"	SMF1248
72"	SMF1272
96"	SMF1296
120"	SMF1220

- Width : 1-5/8"
- Height: 1-5/8"
- Available in powder coated steel or stainless steel.

Channels 1-5/8" x 13/16"

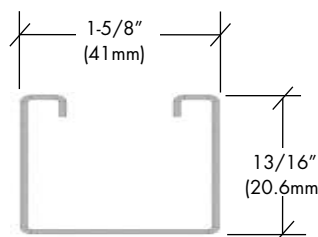

Length	12 Gauge
24"	SMF1624
48"	SMF1648
72"	SMF1672
96"	SMF1696
120"	SMF1620

- Width : 1-5/8"
- Height: 13/16"
- Available in powder coated steel or stainless steel.

MISCELLANEOUS ITEMS

METAL FRAMING SYSTEM

Channel Nuts

Channel nuts are machined from steel bars and are case hardened. Nuts are designed with shaped ends that allow them to be turned clockwise within the channel after insertion through the opening. The channel nut is held in place when the two grooves with the serrated teeth engage the inturns of the channel after the bolt is tightened. This stops any movement of the nut and bolt within the framing member. Channel nuts conform to ASTM Specification A1011 SS GR 33 (material only). Screws conform to SAE J429 GR.



Item Number

- SMFN100
- Thread: 3/8"-16
 - Thickness: 1/4"
 - For use with 1-5/8" X 13/16" Channel
 - Box of 100 pcs.



Item Number

- SMFN200
- Thread: 3/8"-16
 - Thickness: 3/8"
 - For use with 1-5/8" X 1-5/8" Channel
 - Box of 100 pcs.

Miscellaneous Hardware



Hex Head Bolt 1"

SMFB100



Hex Head Bolt 1-1/4"

- SMFB200
- Thread 3/8"-16
 - Box of 100 pcs.



Lock Washer

- SMFLW00
- Size: 3/8"
 - Box of 100 pcs.



Flat Washer

- SMFFW00
- Size: 3/8"
 - Box of 100 pcs.



Hex Nut

- SMFH00
- Size: 3/8"
 - Box of 100 pcs.



Threaded Rod

- SMFT00
- Thread: 3/8"-16
 - Length: 6'
 - Electro-galvanized

MISCELLANEOUS ITEMS

METAL FRAMING SYSTEM

Note: No modifications are possible on flat plate and 90° angle fittings.

Flat Plate Fittings

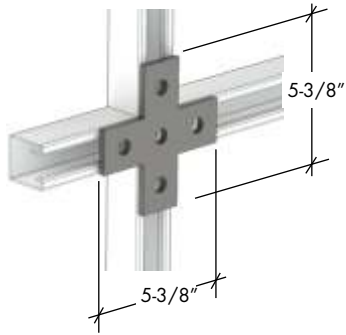

Item Number
SMFFP00
• Thickness: 1/4"
• Hole Diameter: 9/16" DIA.



Item Number
SMFFP03
• Thickness: 1/4"
• Hole Diameter: 9/16" DIA.

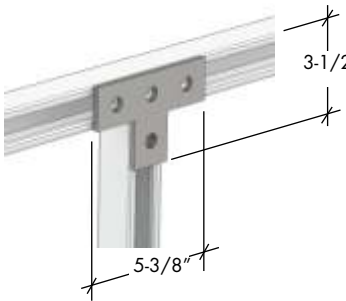

Item Number
SMFFP01
• Thickness: 1/4"
• Hole Diameter: 9/16" DIA.



Item Number
SMFFP04
• Thickness: 1/4"
• Hole Diameter: 9/16" DIA.

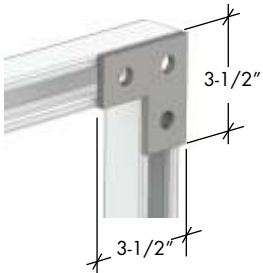

Item Number
SMFFP02
• Thickness: 1/4"
• Hole Diameter: 9/16" DIA.

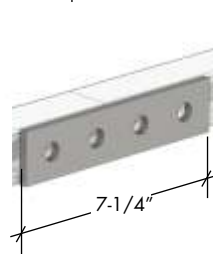

Item Number
SMFFP05
• Thickness: 1/4"
• Hole Diameter: 9/16" DIA.

90° Angle Fittings

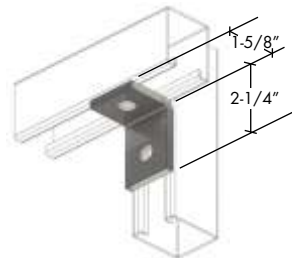

Two Hole Corner 1-5/8" x 2-1/4"
SMFAF00
• Thickness: 1/4"
• Width: 1-5/8"
• Hole Diameter: 9/16"
• Hole Spacing: 1-7/8"
• Edge Distance: 13/16"

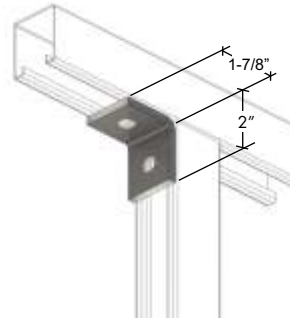

Two Hole Corner 1-7/8" x 2"
SMFAF10
• Thickness: 1/4"
• Width: 1-5/8"
• Hole Diameter: 9/16"
• Hole Spacing: 1-7/8"
• Edge Distance: 13/16"

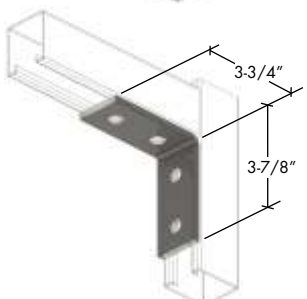

Four Hole Corner 3-3/4" x 3-7/8"
SMFAF20
• Thickness: 1/4"
• Width: 1-5/8"
• Hole Diameter: 9/16"
• Hole Spacing: 1-7/8"
• Edge Distance: 13/16"

MISCELLANEOUS ITEMS

METAL FRAMING SYSTEM

Shelf Brackets

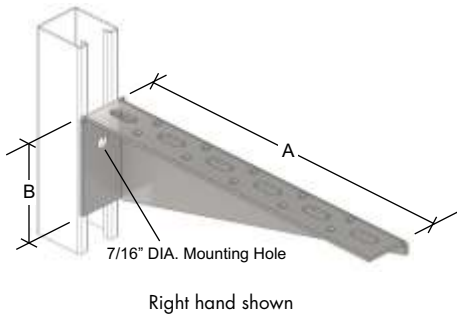

Length A	Height B	Right Hand Bracket	Left Hand Bracket
12"	3-7/16"	SMFRH12	SMFLH12
14"	3-15/16"	SMFRH14	SMFLH14
16"	4-7/16"	SMFRH16	SMFLH16
18"	4-15/16"	SMFRH18	SMFLH18
20"	5-7/16"	SMFRH20	SMFLH20
22"	5-15/16"	SMFRH22	SMFLH22

- Thickness: 12 gauge
- Number of Slots = A/2
- Number of Rows of Holes = (A/2) - 1
- No modification are possible.

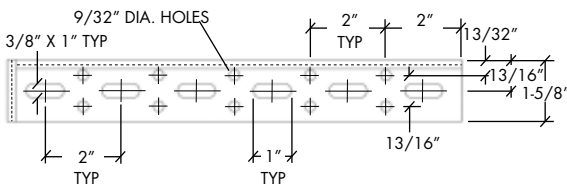

Hat Channel Shelf Brackets For Wall Struts

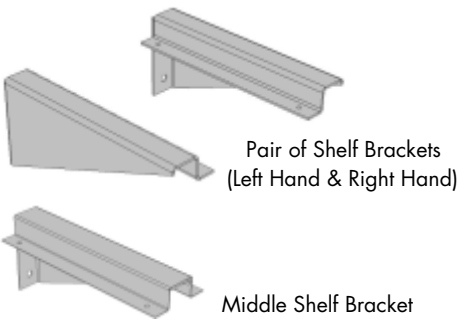

Depth	Pair of Brackets	Middle Bracket
10"	TBPO010	TBDO010
12"	TBPO012	TBDO012
14"	TBPO014	TBDO014
16"	TBPO016	TBDO016
18"	TBPO018	TBDO018

- Steel shelf brackets suitable for Wall Struts.
- 5" high.

Shelf Brackets For Wall Struts

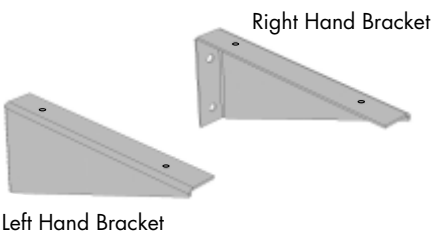

Depth	Left Hand Bracket	Right Hand Bracket
10"	TSLO010	TSRO010
12"	TSLO012	TSRO012
14"	TSLO014	TSRO014
16"	TSLO016	TSRO016
18"	TSLO018	TSRO018

- Steel shelf brackets suitable for Wall Struts.
- 5" high.

MISCELLANEOUS ITEMS

METAL FRAMING SYSTEM

Note: No modifications are possible on post bases.

Post Bases

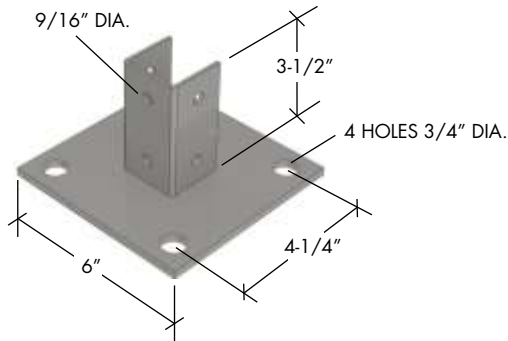

Item Number

SMFPB10

. Thickness: 1/4"

. Hole Diameter: 3/4" DIA.

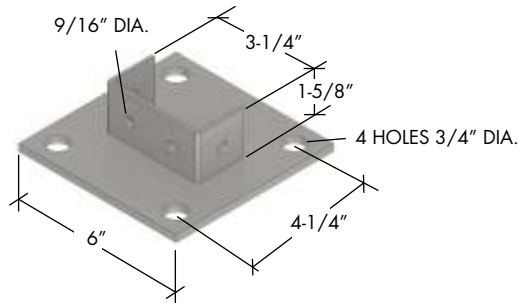

Item Number

SMFPB20

. Thickness: 1/4"

. Hole Diameter: 3/4" DIA.

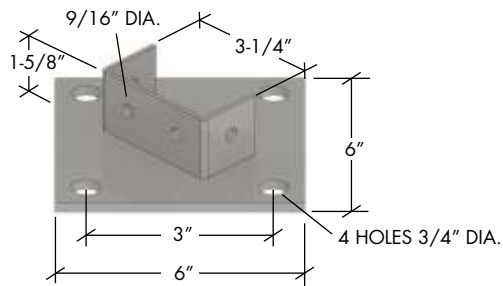

Item Number

SMFPB30

. Thickness: 1/4"

. Hole Diameter: 3/4" DIA.

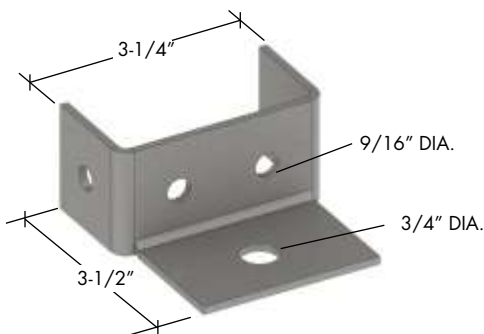

Item Number

SMFPB40

. Thickness: 1/4"

. Hole Diameter: 9/16" DIA.

MISCELLANEOUS ITEMS OPTIONS

Option Code	Description
00	Modified door/drawer configuration
01	Full extension drawer runners
02	Label holders on all doors/drawers
03	Numeric or alpha identification disks on all doors/drawers (customer details required)
07	Cut-outs for electrical and/or plumbing services (customer drawing required)
09	Stainless steel waste flap
10	One fixed drawer divider per drawer (centered in drawer)
11	Multiple drawer dividers per drawer (customer drawing required)
12	Pull out writing board - all cold rolled steel*
13	Pull out writing board - cold rolled steel & high pressure laminate writing surface*
14	Ventilation grill in toe kick base
16	Ship handles not installed
17	Nylon levelers
19	Replaces standard drawer(s) with full width drawer(s) on 5" high apron
26	200 lbs full extension drawer runners
48	Keyboard tray (replaces drawer)
79	Other customer specified base or toe kick
FCW	Front corners welded
OL	Overlay design
PFE	Pull out writing board on full extension runners*
PW	Pre-wired (option code not to be used for fume hoods, customer details required)
SK	Skid item
S01	Full extension soft close drawer runners
S26	200lbs full extension soft close drawers runners
WF	Wood fronts - see specifications
WO	Wood fronts provided and installed by others