

CASEWORK CONSTRUCTION DETAILS

Overview

Cabinets

Mott casework can meet the most demanding specification, whether it is AWI Premium or an architect's 'signature' specification. We manufacture using premium grade techniques and using materials as outlined by the architect or lab planner in the specifications of each project. A variety of veneer panels and glues are available to meet just about any environmental, appearance, or durability requirement. Most of our cabinets are available in SEFA compliant versions; contact Mott for details.

Each base cabinet has a 1" thick top front rail and 3/4" thick optional intermediate rail, 3/4" thick top and bottom back rails and are joined together with concealed hardwood dowels and NAUF glue. The front exposed edge is hardwood edgebanded in the same species as the face veneer. Wall and floor cabinets have 1" top panels and wall cabinets also have 1" bottom panels. Toe spaces are 3" deep by 4" high.

Base cabinets with doors have a full height tempered hardboard removable back panel. Drawer cabinets have no back panels (open backs) with optional split back panel. Sink cabinets have a partial back panel to facilitate plumbing. Open and glazed door wall cabinets and floor cabinets have veneered back panels.

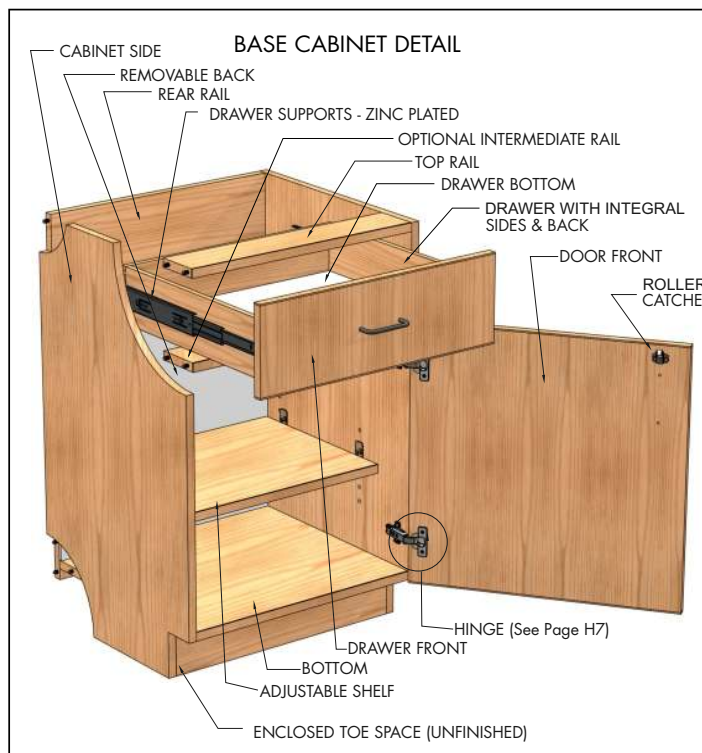

Doors & Drawers

Solid door and drawer fronts are 3/4" particleboard. Drawer bodies are NAUF, 1/2" 9-ply Baltic Birch, dovetailed at all four corners. Solid maple, powder coated cold rolled steel and stainless steel are other options available. Drawer bottoms are 1/4" hardboard or veneered panel that are let into routed grooves on all four sides of the drawer body and hot glued along the entire perimeter on the bottom. Drawer fronts and doors are edgebanded with hardwood of the same species as the face veneer.

Hardware, Drawer Suspension & Glass

Doors that are 48" high and higher have at least three hinges and doors that are less than 48" high have two hinges. Five knuckle, three knuckle barrel hinge and concealed European style hinges and a wide selection of handles available. Standard drawer suspension is 100 lbs full extension runners, optional suspension systems are available. File drawers are minimum 150lbs full extension. Glass on framed doors shall be 1/8" (3mm) float glass, and 1/4" (6mm) on all floor cases and base cabinets). Glass for unframed sliding glass doors shall be 1/4" (6mm). Framed glass held in place with a removable clear plastic retainer and sliding doors shall be set in an extruded aluminum track.

Shelves

Shelves are made from veneer core panel product of the same species specified for the face veneer. Shelves are 1" thick, adjustable on 1-1/4" increments and held in place via seismic plastic twin pin supports, other shelf clips are available. The front edge is hardwood edgebanded in the same species as the face veneer.

Table Frames & Apron Panels

Frames are 3-3/4" high and 3/4" thick lumber. Legs are 2-1/8" X 2-1/8" solid lumber with 4" high shoes. Apron frames are bracketed and securely bolted together, legs are shipped unassembled (unless otherwise noted).

Green Options

Mott is certified by Rainforest Alliance to the FSC® (FSC® C051171) Chain of Custody standard: Offering certified and sustainable materials and no added urea-formaldehyde (NAUF) products.

Quality

Our commitment to quality through our ISO Quality Management System assures the reliable, long life of your laboratory furniture.

TYPICAL WORK AREA

Details

The following details are provided to illustrate how base cabinets (see page H3 for open, sliding door and inset cabinet depth dimensions), filler panels and counter tops combine to construct a laboratory work area.

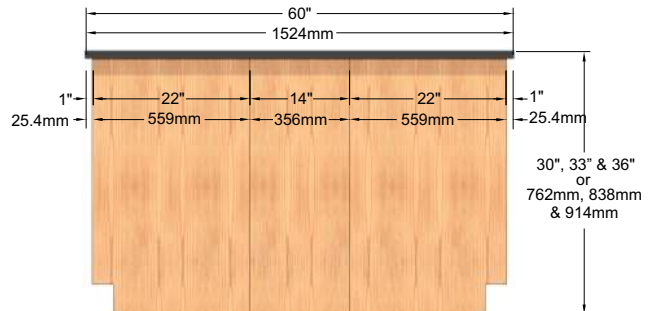
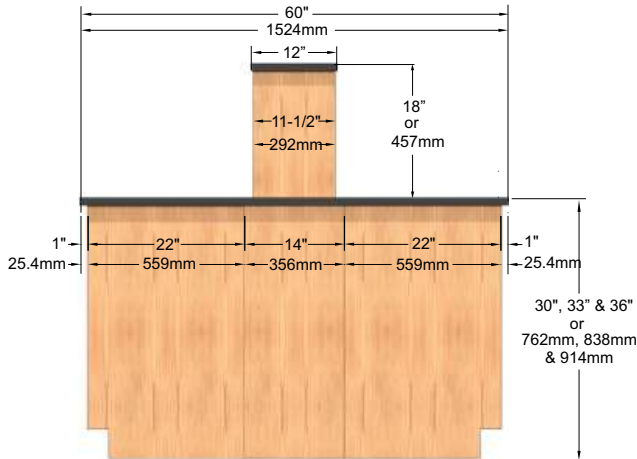

- Above is an island type configuration with 60" wide counter top, (2) 22" deep cabinets (overall depth, includes cabinet fronts), a 14" removable filler panel and 12" reagent shelf.
- The area covered by the 14" removable filler panel provides a large accessible space for required services.
- Both base cabinet side panels can also be extended to 29" deep to eliminate the use of a 14" filler and provide a continuous cabinet look, cabinet interior will remain 20-1/8" deep.

- Above is an island type configuration with 60" wide counter top, (2) 22" deep cabinets (overall depth, includes cabinet fronts), and a 14" removable filler panel.
- The area covered by the 14" removable filler panel provides a large accessible space for required services.
- Both base cabinet side panels can also be extended to 29" deep to eliminate the use of a 14" filler and provide a continuous cabinet look, cabinet interior will remain 20-1/8" deep.

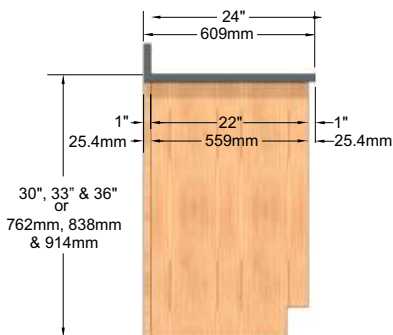

- Above is a standard base cabinet configuration with 24" deep counter top, 22" deep base cabinet (overall depth, includes cabinet fronts), and 1" filler panel.
- Base cabinet side panels can also be extended to 23" deep to eliminate the use of a 1" filler and provide a continuous cabinet look, cabinet interior will remain 20-1/8" deep.

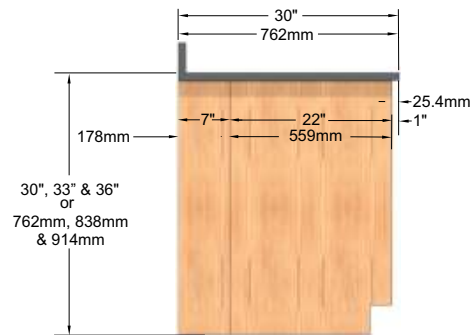

- Above is a base cabinet configuration with 30" deep counter top, 22" deep base cabinet (overall depth, includes cabinet fronts), and 7" removable filler panel.
- The area covered by the 7" removable filler panel provides accessible space for required services.
- Base cabinet side panels can also be extended to 29" deep to eliminate the use of a 7" filler and provide a continuous cabinet look, cabinet interior will remain 20-1/8" deep.

CABINET DIMENSIONS

Base Cabinets - Full Flush & Reveal Overlay

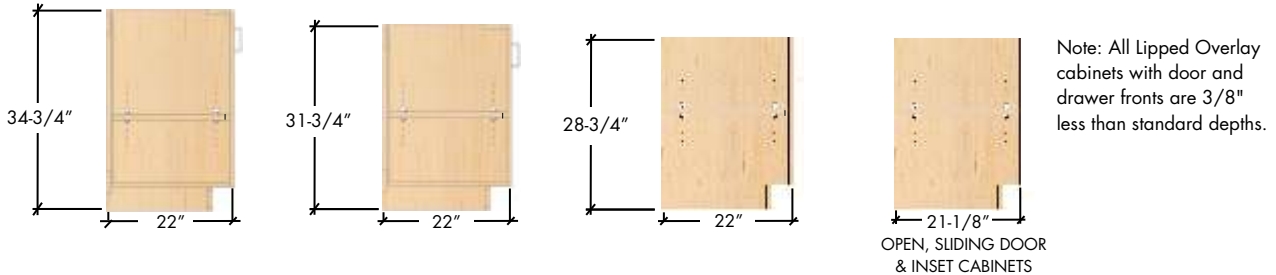

Wall Cabinets - Full Flush & Reveal Overlay

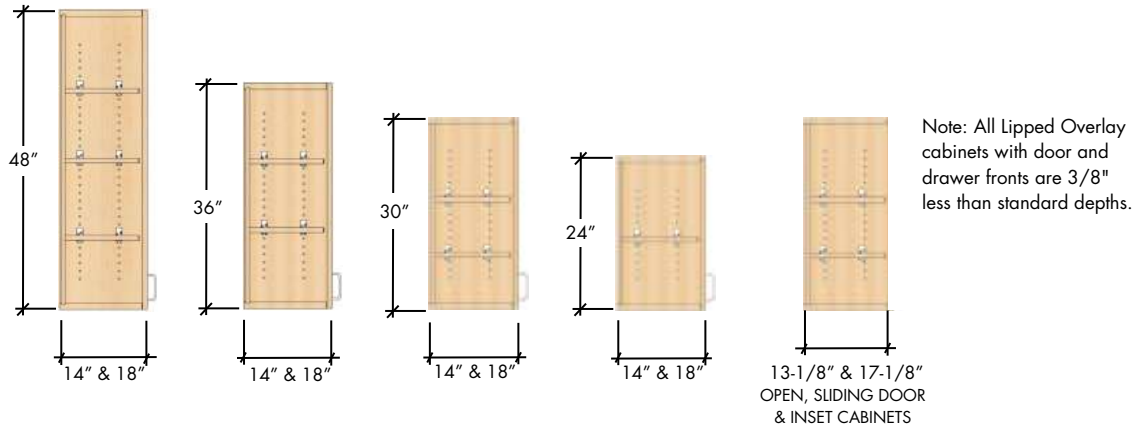

Floor Cabinets - Full Flush & Reveal Overlay

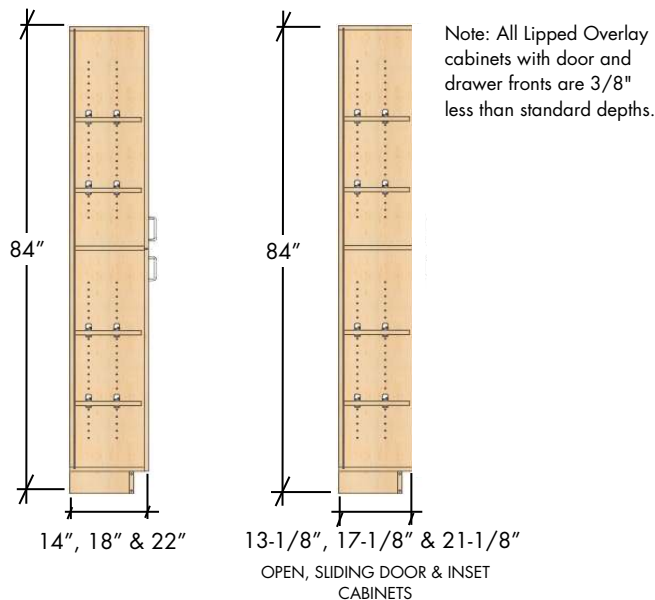

Overlay Wood Cabinet Body Depths

Open and sliding door cabinets will be constructed with the same dimensional standards as any other cabinet except that it will not have door or drawer fronts, meaning that 7/8" of the Reveal and Full Flush overlay fronts will be missing from the overall depth.

Open, sliding door and inset cabinets may be ordered 7/8" deeper so that cabinet faces line up with the doors and drawer fronts on adjacent Full Flush and Reveal cabinets. See below for ordering details.

OLD option code can be applied to open cabinets, sliding door cabinets, cabinets with inset doors, aprons, kneespace ADA sink units and gable legs. This brings the actual depth to 22" deep with a 3" deep toekick.

OLP option code can be applied to front fillers, wall fillers, ADA sink units, aprons and wall cabinet furring panels. A 7/8" panel is added to the front to make the overall depth 22".

OPTIONS
Veneer Species & Cut

- | | |
|---|---|
| <input type="checkbox"/> Red Oak - Plain Sliced | <input type="checkbox"/> Beech, European Steamed - Quarter Sliced |
| <input type="checkbox"/> Red Oak - Rift Cut | <input type="checkbox"/> Beech, European Steamed - Plain Sliced |
| <input type="checkbox"/> Maple - Plain Sliced | <input type="checkbox"/> Birch - Rotary Sliced |
| <input type="checkbox"/> Maple - Quarter Sliced | <input type="checkbox"/> Cherry - Plain Sliced |
| <input type="checkbox"/> Maple - Rotary Sliced | <input type="checkbox"/> Cherry - Rotary Sliced |
| <input type="checkbox"/> Anigre - Quarter Cut, Plain Figure | <input type="checkbox"/> Sapele, Ribbon - Quarter Sliced |
| <input type="checkbox"/> Ash - Plain Sliced | <input type="checkbox"/> Walnut - Plain Sliced |
| <input type="checkbox"/> Ash - Rift Cut | <input type="checkbox"/> Walnut - Quarter Sliced |
| <input type="checkbox"/> Bamboo, Natural - Edge Cut | <input type="checkbox"/> White Sapele, Quarter Sliced |
| <input type="checkbox"/> Bamboo, Caramelized - Edge Cut | <input type="checkbox"/> Other species & cuts available (Specify) |

Grain Match

- Book Match (Standard)
- Slip Match
- Other (Specify)

Stains

- Natural
- Cashew
- Ginger
- Toffee
- Cider
- Hazelnut
- Custom (Specify)

Standards

- AWI Premium (Standard)
- Other (specify)

Environmental

- None (Standard)
- NAUF
- FSC
- NAUF & FSC
- Other

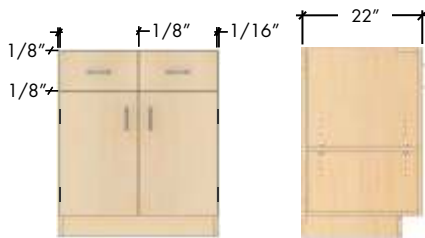
Cabinet Construction Style

- Full Flush Overlay (Standard)
Feature square-edged door and drawer fronts with tight reveals by notching around the hinge

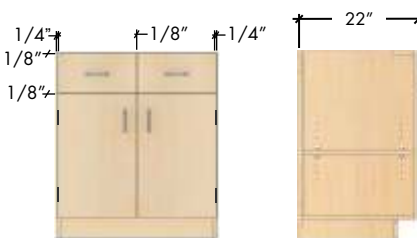

- Reveal Overlay
Feature square-edged door and drawer fronts with no hinge notching on the doors providing balanced reveals

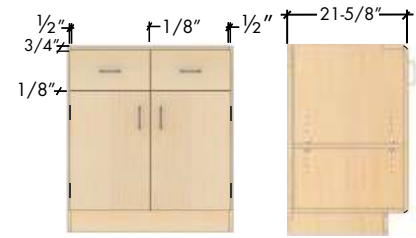

- Lipped Overlay
Feature radisused edged door and drawer fronts with a combination grain direction

Cabinet Top Frame

- Front & Back Rails (Standard)
Front horizontal and rear vertical rails



- Full Top Frame
Front, rear and side horizontal rails

Base Construction

- Integral with end panels to the floor, with toe kick, without levelers (Standard)
- Integral with end panels to the floor, with toe kick, with levelers
- Other (specify)

OPTIONS

Removable Back Panel On Base Cabinet



- One Piece Tempered Hardboard (Standard)
(No backs provided on drawer units)
- White Melamine
- Veneered



- Two Piece Tempered Hardboard
- White Melamine
- Veneered



- Other (Specify)

Cabinet Body Core Material

- Veneer Core (Standard)
- Particleboard Core
- MDF Core
- Combination Core

Door & Drawer Front Core

- Particleboard Core (Standard)
- MDF Core
- Combination Core

Cabinet Edgebanding

- Roll Type Edgeband 100% Hardwood, 1/8" Thick (Standard)
- Stick Edgeband 1/8" Thick
- Stick Edgeband 1/4" Thick

Grain Direction



- Vertical Matched (Standard)
Both drawers and doors have a vertical matched grain direction



- Combination
Drawer grain direction is horizontal and door grain direction is vertical

Cabinet Shelf Depth



- Full Depth Shelf (Standard)
Measures 3/4" shorter than the inside depth of cabinet



- Half Depth Shelf
Accommodates storage of tall apparatus in front of shelf



- Split Depth Shelf
Capable being a Half Depth and a Full Depth shelf

Base Cabinets - One shelf provided.

Wall Cabinets - 48" high or higher: three shelves provided, 30" high - 47" high: two shelves provided, 29" high or less: one shelf provided.

Floor Cabinets - Five shelves provided (one fixed, four adjustable), unless otherwise noted.

OPTIONS

Drawer Construction

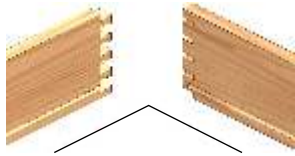

- 1/2" 9-ply, Baltic Birch, Dovetail Drawer Bodies (Standard)

- Drawer Bottoms, fully captured
- Hardboard (Standard)
 - White Melamine
 - Veneered

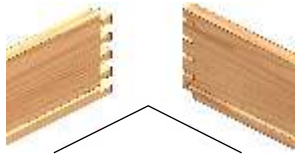

- Solid Maple, Dovetail Drawer Body

- Drawer Bottoms, fully captured
- Hardboard (Standard)
 - White Melamine
 - Veneered

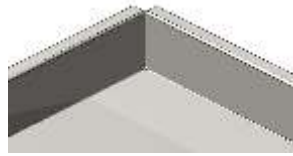

- Powder Coated Steel Drawer Bodies

One, full piece, powder coated 20 gauge, cold rolled steel with reinforcing bend on all top edges



- Stainless Steel Drawer Bodies
Drawer with integral sides and back, constructed using 20 gauge, 304 stainless steel with a #4 finish

Drawer Suspension



- Full extension, 100 lb, zinc plated steel runners (Standard)
- Full extension, 100lb with soft/self-close feature, zinc plated steel runners



- Full extension, 200lb, zinc plated steel runners
- Full extension, 200 lb, with soft/self-close feature, zinc plated steel runners



- 3/4 extension, 100lb, epoxy coated nylon tire runners

Drawer/Door Pull Direction



- Configuration 1 (Standard)
Pulls are horizontal on all drawers, and vertical on all doors



- Configuration 2
Pulls are horizontal on all drawers and doors. Floor cabinets have vertical pulls

Drawer & Door Pulls



- Option 62 (Standard)
4" Brushed Aluminum Pull
- Option 65
4" Flush Chrome plated Pull



- Option 61
4" Tubular Stainless Steel Pull
- Option 68
4" Aluminum Wire Pull
- Option 6B
4" Black Wire Pull



- Option 63
4" Chrome Pull



- Option 60
4" Black Nylon Pull

- Other (Specify)

OPTIONS

Door Hinges



- Dull Chrome Overlay Hinge (Standard) Option 20
 - Stainless Steel Overlay Hinge Option 24
 - Black Overlay Hinge Option DH2

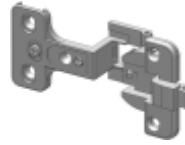

- Three Knuckle Hinge Option 27



- Euro Concealed Hinge Option 28

Door Catches



- Roller Catch (Standard)



- Magnetic Catch

Label Holder

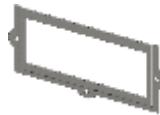

- None (Standard)
- Label Holder - One per door, one per drawer
- Label Holder - File drawers only
- Label Holder - All drawers only

Shelf Clips

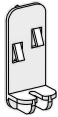

- Plastic Twin-Pin (Standard)
Seismic suited



- Steel Pin With Angle



- Recessed Mounting Pilaster and Clips

Glass



- Framed Glass Wall Cabinet
- Float Glass 1/8" (3mm) (Standard)
 - Tempered Safety Glass 1/8" (3mm)
 - Laminated Safety Glass 1/4" (6mm)

- Framed Glass Floor & Base Cabinets
- Float Glass 1/4" (6mm) (Standard)
 - Tempered Safety Glass 1/4" (6mm)
 - Laminated Safety Glass 1/4" (6mm)

Note: Floor & base cabinets not shown



- Unframed Wall, Floor & Base Cabinets With Flush Pull
- Float Glass 1/4" (6mm) (Standard)
 - Tempered Safety Glass 1/4" (6mm)
 - Laminated Safety Glass 1/4" (6mm)

Note: Floor & base cabinets not shown

Extended Ends

Extended Ends option is available in 1" increments from 1" to 9" on any unit you wish to have extended. When choosing this option change the last digit to the extended length you require. Eg: XB1 = Extended End Both of 1". This option comes standard as a finished end.



- Extended ends, both side



- Extended end, left side

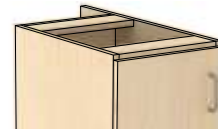

- Extended end, right side

OPTIONS

Lock & Key Options



- Option 30 (Standard)*
5-Disc Master,
removable core
- Option IK4
5-Pin Tumbler, removable
core, 3 level keying



- Option 37
Hasp Lock
(padlock not included)



- Option 37A
Hasp Lock with stainless
steel plate
(padlock not included)

- Option 31 - Provisions for standard locks on doors/drawers (holes and tabs)*
 - Option 38 - Customer specified locks on doors/drawers supplied and factory installed**
 - Option 39 - Customer specified locks on doors/drawers supplied and not factory installed **
 - Option BS - Best locks (housing only), core not provided
- *Standard lock is a disc tumbler lock. Each cabinet is keyed differently per unit unless otherwise specified.
**Provide complete specification and source for all special options ordered.

All Locks Keyed Different Per Unit

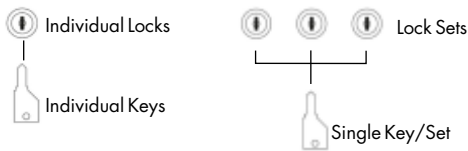

Locks are keyed different per unit from other units.
Note: This is the standard key schedule with disc tumbler lock supplied for option code 30 unless otherwise specified.

Master Keyed Locks

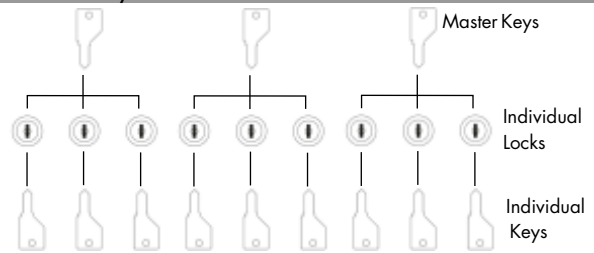

All locks are keyed different from all other locks. Each set within a group can be opened with a master key. Up to 229 key changes for disc are available.

All Locks Keyed Alike

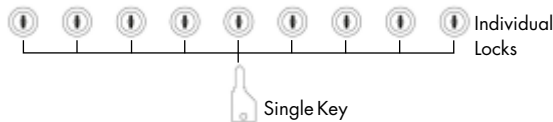

All locks are keyed alike, each lock can be opened with a single key.

Pin Locks Keyed Different, Grand Master & Master Keyed

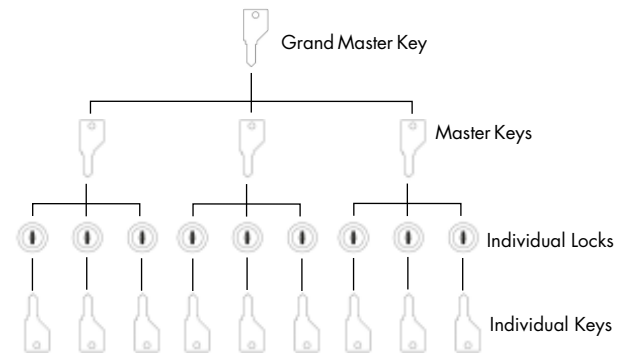

All locks are keyed different from all other locks. Each set within a group can be opened with a master key. All groups can be opened with a grand master key. 400 key changes and up to 10 master keys.

Locks Keyed Alike in Sets

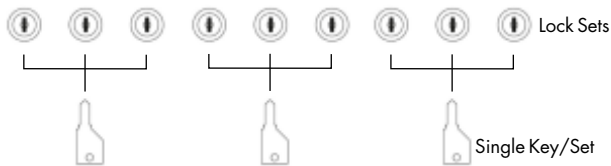

Locks are keyed alike in sets. Only one key will open one set of locks within the set. Up to 229 key changes for disc are available.

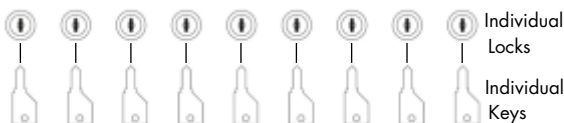

Locks are keyed different from other locks. Up to 229 key changes for disc are available.

BASE CABINETS

34-3/4" HIGH X 22" DEEP

Open Units



Width	Item Number
12"	101000W
15"	191000W
18"	111000W
24"	121000W
30"	131000W
36"	141000W
42"	181000W
48"	151000W
513mm	161000W
1000mm	171000W

• Actual depths 7/8" less than nominal.

Full Door Units



up to 24" wide



30" and wider

Width	Right Hinged	Left Hinged	# of Doors
12"	1010011W	1010211W	1
15"	1910011W	1910211W	1
18"	1110011W	1110211W	1
24"	1210011W	1210211W	1
30"	1310011W	-	2
36"	1410011W	-	2
42"	1810011W	-	2
48"	1510011W	-	2
513mm	1610011W	1610211W	1
1000mm	1710011W	-	2

Door/Drawer Units



up to 24" wide



30" and wider

Width	Right Hinged	Left Hinged	# of Doors
12"	1010022W	1010222W	1
15"	1910022W	1910222W	1
18"	1110022W	1110222W	1
24"	1210022W	1210222W	1
30"	1310022W	-	2
36"	1410022W	-	2
42"	1810022W	-	2
48"	1510022W	-	2
513mm	1610022W	1610222W	1
1000mm	1710022W	-	2



up to 24" wide



30" and wider

Width	Right Hinged	Left Hinged	# of Doors
12"	1010033W	1010233W	1
15"	1910033W	1910233W	1
18"	1110033W	1110233W	1
24"	1210033W	1210233W	1
30"	1310033W	-	2
36"	1410033W	-	2
42"	1810033W	-	2
48"	1510033W	-	2
513mm	1610033W	1610233W	1
1000mm	1710033W	-	2



Width	Item Number
30"	1310093W
36"	1410093W
42"	1810093W
48"	1510093W
1000mm	1710093W



Width	Item Number
30"	1310096W
36"	1410096W
42"	1810096W
48"	1510096W
1000mm	1710096W

BASE CABINETS

34-3/4" HIGH X 22" DEEP

Door/Drawer Units



Width	Right Hand	Left Hand
30"	1310032W	1310023W
36"	1410032W	1410023W
42"	1810032W	1810023W
48"	1510032W	1510023W
1000mm	1710032W	1710023W

- Left hand door/drawer unit shown.
- Right hand reversed.



Width	Right Hand	Left Hand
30"	1310021W	1310012W
36"	1410021W	1410012W
42"	1810021W	1810012W
48"	1510021W	1510012W
1000mm	1710021W	1710012W

- Left hand door/drawer unit shown.
- Right hand reversed.



Width	Right Hand	Left Hand
30"	1310031W	1310013W
36"	1410031W	1410013W
42"	1810031W	1810013W
48"	1510031W	1510013W
1000mm	1710031W	1710013W

- Left hand door/drawer unit shown.
- Right hand reversed.



Width	Right Hand	Left Hand
30"	1310041W	1310014W
36"	1410041W	1410014W
42"	1810041W	1810014W
48"	1510041W	1510014W
1000mm	1710041W	1710014W

- Left hand door/drawer unit shown.
- Right hand reversed.



Width	Right Hand	Left Hand
30"	1310051W	1310015W
36"	1410051W	1410015W
42"	1810051W	1810015W
48"	1510051W	1510015W
1000mm	1710051W	1710015W

- Left hand door/drawer unit shown.
- Right hand reversed.



Width	Right Hand	Left Hand
30"	1310061W	1310016W
36"	1410061W	1410016W
42"	1810061W	1810016W
48"	1510061W	1510016W
1000mm	1710061W	1710016W

- Left hand door/drawer unit shown.
- Right hand reversed.



Width	Right Hand	Left Hand
30"	1310071W	1310017W
36"	1410071W	1410017W
42"	1810071W	1810017W
48"	1510071W	1510017W
1000mm	1710071W	1710017W

- Left hand door/drawer unit shown.
- Right hand reversed.



Width	Right Hand	Left Hand
30"	1310081W	1310018W
36"	1410081W	1410018W
42"	1810081W	1810018W
48"	1510081W	1510018W
1000mm	1710081W	1710018W

- Left hand door/drawer unit shown.
- Right hand reversed.



Width	Right Hand	Left Hand
30"	1310942W	1310924W
36"	1410942W	1410924W
42"	1810942W	1810924W
48"	1510942W	1510924W
1000mm	1710942W	1710924W

- Left hand door/drawer unit shown.
- Right hand reversed.



Width	Right Hand	Left Hand
30"	1310042W	1310024W
36"	1410042W	1410024W
42"	1810042W	1810024W
48"	1510042W	1510024W
1000mm	1710042W	1710024W

- Left hand door/drawer unit shown.
- Right hand reversed.



Width	Right Hand	Left Hand
30"	1310052W	1310025W
36"	1410052W	1410025W
42"	1810052W	1810025W
48"	1510052W	1510025W
1000mm	1710052W	1710025W

- Left hand door/drawer unit shown.
- Right hand reversed.



Width	Right Hand	Left Hand
30"	1310062W	1310026W
36"	1410062W	1410026W
42"	1810062W	1810026W
48"	1510062W	1510026W
1000mm	1710062W	1710026W

- Left hand door/drawer unit shown.
- Right hand reversed.

All dimensions and sizes shown are nominal. Specifications and details are based on product information at the time of printing and may change at any time without notice. Mott Manufacturing reserves the right to change dimensions, specifications and manufacturing details at any time without notice.

BASE CABINETS

34-3/4" HIGH X 22" DEEP

Door/Drawer Units



Width	Right Hand	Left Hand
30"	1310072W	1310027W
36"	1410072W	1410027W
42"	1810072W	1810027W
48"	1510072W	1510027W
1000mm	1710072W	1710027W

- Left hand door/drawer unit shown.
- Right hand reversed.



Width	Right Hand	Left Hand
30"	1310043W	1310034W
36"	1410043W	1410034W
42"	1810043W	1810034W
48"	1510043W	1510034W
1000mm	1710043W	1710034W

- Left hand door/drawer unit shown.
- Right hand reversed.



Width	Right Hand	Left Hand
30"	1310053W	1310035W
36"	1410053W	1410035W
42"	1810053W	1810035W
48"	1510053W	1510035W
1000mm	1710053W	1710035W

- Left hand door/drawer unit shown.
- Right hand reversed.



Width	Right Hand	Left Hand
30"	1310063W	1310036W
36"	1410063W	1410036W
42"	1810063W	1810036W
48"	1510063W	1510036W
1000mm	1710063W	1710036W

- Left hand door/drawer unit shown.
- Right hand reversed.



Width	Right Hand	Left Hand
30"	1310073W	1310037W
36"	1410073W	1410037W
42"	1810073W	1810037W
48"	1510073W	1510037W
1000mm	1710073W	1710037W

- Left hand door/drawer unit shown.
- Right hand reversed.

Drawer Units



up to 24" wide



30" and wider

Width	Item Number
12"	1010044W
15"	1910044W
18"	1110044W
24"	1210044W
30"	1310044W
36"	1410044W
42"	1810044W
48"	1510044W
513mm	1610044W
1000mm	1710044W



up to 24" wide



30" and wider

Width	Item Number
12"	1010055W
15"	1910055W
18"	1110055W
24"	1210055W
30"	1310055W
36"	1410055W
42"	1810055W
48"	1510055W
513mm	1610055W
1000mm	1710055W

BASE CABINETS

34-3/4" HIGH X 22" DEEP

Door/Drawer Units



up to 24" wide



30" and wider



up to 24" wide



30" and wider



up to 24" wide



30" and wider



up to 24" wide



30" and wider



Width	Item Number
30"	1310A91W
36"	1410A91W
42"	1810A91W
48"	1510A91W
1000mm	1710A91W



Width	Item Number
30"	1310090W
36"	1410090W
42"	1810090W
48"	1510090W
1000mm	1710090W

Width	Item Number
12"	1010066W
15"	1910066W
18"	1110066W
24"	1210066W
30"	1310066W
36"	1410066W
42"	1810066W
48"	1510066W
513mm	1610066W
1000mm	1710066W

Width	Item Number
12"	1010077W
15"	1910077W
18"	1110077W
24"	1210077W
30"	1310077W
36"	1410077W
42"	1810077W
48"	1510077W
513mm	1610077W
1000mm	1710077W

Width	Item Number
12"	10100BBW
15"	19100BBW
18"	11100BBW
24"	12100BBW
30"	13100BBW
36"	14100BBW
42"	18100BBW
48"	15100BBW
513mm	16100BBW
1000mm	17100BBW

Width	Item Number
12"	1010090W
15"	1910090W
18"	1110090W
24"	1210090W
30"	13100NNW
36"	14100NNW
42"	18100NNW
48"	15100NNW
513mm	1610090W
1000mm	17100NNW

BASE CABINETS

34-3/4" HIGH X 22" DEEP

Door/Drawer Units



Width	Item Number
30"	1310097W
36"	1410097W
42"	1810097W
48"	1510097W
1000mm	1710097W



Width	Item Number
30"	1310098W
36"	1410098W
42"	1810098W
48"	1510098W
1000mm	1710098W



Width	Item Number
30"	1310091W
36"	1410091W
42"	1810091W
48"	1510091W
1000mm	1710091W



Width	Item Number
30"	1310099W
36"	1410099W
42"	1810099W
48"	1510099W
1000mm	1710099W



Width	Item Number
30"	1310B44W
36"	1410B44W
42"	1810B44W
48"	1510B44W
1000mm	1710B44W



Width	Right Hand	Left Hand
30"	1310094W	1310092W
36"	1410094W	1410092W
42"	1810094W	1810092W
48"	1510094W	1510092W
1000mm	1710094W	1710092W

- Left hand drawer unit shown.
- Right hand reversed.



Width	Item Number
30"	1310095W
36"	1410095W
42"	1810095W
48"	1510095W
1000mm	1710095W



Width	Right Hand	Left Hand
30"	1310019W	1310029W
36"	1410019W	1410029W
42"	1810019W	1810029W
48"	1510019W	1510029W
1000mm	1710019W	1710029W

- Left hand drawer unit shown.
- Right hand reversed.



Width	Item Number
30"	1310039W
36"	1410039W
42"	1810039W
48"	1510039W
1000mm	1710039W



Width	Item Number
30"	13100CCW
36"	14100CCW
42"	18100CCW
48"	15100CCW
1000mm	17100CCW

File Drawer Units



up to 24" wide



30" and wider

Width	Item Number
12"	1A10133W
15"	1910133W
18"	1110133W
24"	1210133W
30"	1310133W
36"	1410133W
42"	1810133W
48"	1510133W
513mm	1610133W
1000mm	1710133W

BASE CABINETS

34-3/4" HIGH X 22" DEEP

File Drawer Units



up to 24" wide



30" and wider



up to 24" wide



30" and wider



up to 24" wide



30" and wider



up to 24" wide



30" and wider

Width	Item Number
15"	1910100W
18"	1110100W
24"	1210100W
30"	1310100W
36"	1410100W
42"	1810100W
48"	1510100W
513mm	1610100W
1000mm	1710100W

Width	Item Number
15"	1910111W
18"	1110111W
24"	1210111W
30"	1310111W
36"	1410111W
42"	1810111W
48"	1510111W
513mm	1610111W
1000mm	1710111W

Width	Item Number
15"	1910122W
18"	1110122W
24"	1210122W
30"	1310122W
36"	1410122W
42"	1810122W
48"	1510122W
513mm	1610122W
1000mm	1710122W

Width	Item Number
15"	19101AAW
18"	11101AAW
24"	12101AAW
30"	13101AAW
36"	14101AAW
42"	18101AAW
48"	15101AAW
513mm	16101AAW
1000mm	17101AAW

Sliding Door Units



Width	Item Number
30"	1310711W
36"	1410711W
42"	1810711W
48"	1510711W
1000mm	1710711W

• Actual depth 7/8" less than nominal.

BASE CABINETS

34-3/4" HIGH X 22" DEEP

Waste/Storage Bin Units



up to 24" wide



30" and wider

Width	Item Number	# of Bins
15"	1910500W	1
18"	1110500W	1
24"	1210500W	1
30"	1310500W	2
36"	1410500W	2
42"	1810500W	2
48"	1510500W	2
513mm	1610500W	1
1000mm	1710500W	2

- Add option code 84 to order galvanized waste/storage bin.
- Tilt out door is hinged at the bottom.

Corner Units

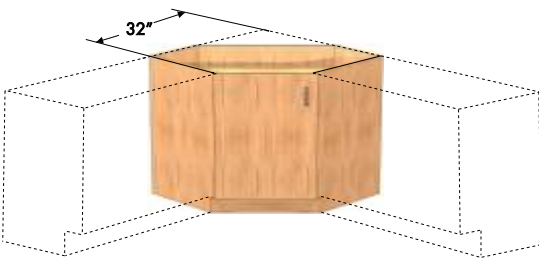
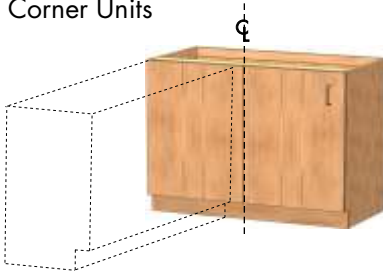

Width	Door on Right	Door on Left
30"	1310311W	1310411W
36"	1410311W	1410411W
42"	1810311W	1810411W
48"	1510311W	1510411W
1000mm	1710311W	1710411W

- Right door corner unit shown.
- Left door corner unit reversed.
- Center stile is located at the middle point.

Description	Right Hinged	Left Hinged
Full Door Unit	1017011W	1017111W
False Panel Unit	1017422W	1017922W

- Left hinge, full door corner unit shown.
- Overall depth of this unit is 22-3/4" from the front of the door to the back of the cabinet.
- Add option code 89 to order a lazy susan.

BASE CABINETS

34-3/4" HIGH X 22" DEEP

Sink Units



up to 24" wide



30" and wider

Width	Right Hinged	Left Hinged	# of Doors
12"	1013011W	1013211W	1
15"	1913011W	1913211W	1
18"	1113011W	1113211W	1
24"	1213011W	1213211W	1
30"	1313011W	-	2
36"	1413011W	-	2
42"	1813011W	-	2
48"	1513011W	-	2
513mm	1613011W	1613211W	1
1000mm	1713011W	-	2

- Add option code 90 to order Sink Hanger Supports.



up to 24" wide



30" and wider

Width	Right Hinged	Left Hinged	# of Doors
12"	1018022W	1018222W	1
15"	1918022W	1918222W	1
18"	1118022W	1118222W	1
24"	1218022W	1218222W	1
30"	1318022W	-	2
36"	1418022W	-	2
42"	1818022W	-	2
48"	1518022W	-	2
513mm	1618022W	1618222W	1
1000mm	1718022W	-	2

- Add option code 90 to order Sink Hanger Supports.

End Sink Units



Description	54" Wide	58" Wide
Full Door Unit	9900017W	9900018W
False Panel Unit	9900021W	9900022W

- Full Door End Sink Unit shown.
- Add option code 90 to order Sink Hanger Supports.

Description	54" Wide	58" Wide
Full Door Unit	9900317W	9900318W

- Full Door End Sink Unit shown.
- Add option code 90 to order Sink Hanger Supports.

Corner Sink Units

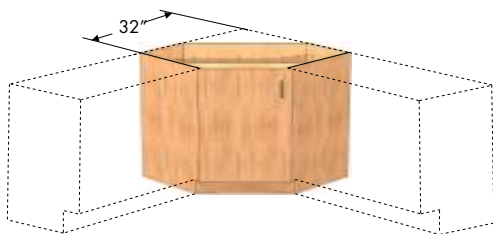

Description	Right Hinged	Left Hinged
Full Door Unit	1017211W	1017511W
False Panel Unit	1017722W	1017622W

- Left Hinge, Corner Sink Unit shown.
- Overall depth of this unit is 22-3/4" from the front of the door to the back of the cabinet.
- Add option code 90 to order Sink Hanger Supports.

BASE CABINETS

28-3/4" HIGH X 22" DEEP

Open Units



Width	Item Number
12"	102000W
15"	192000W
18"	112000W
24"	122000W
30"	132000W
36"	142000W
42"	182000W
48"	152000W
513mm	162000W
1000mm	172000W

• Actual depths 7/8" less than nominal.

Full Door Units



up to 24" wide



30" and wider

Width	Right Hinged	Left Hinged	# of Doors
12"	1020011W	1020211W	1
15"	1920011W	1920211W	1
18"	1120011W	1120211W	1
24"	1220011W	1220211W	1
30"	1320011W	-	2
36"	1420011W	-	2
42"	1820011W	-	2
48"	1520011W	-	2
513mm	1620011W	1620211W	1
1000mm	1720011W	-	2

Door/Drawer Units



up to 24" wide



30" and wider

Width	Right Hinged	Left Hinged	# of Doors
12"	1020022W	1020222W	1
15"	1920022W	1920222W	1
18"	1120022W	1120222W	1
24"	1220022W	1220222W	1
30"	1320022W	-	2
36"	1420022W	-	2
42"	1820022W	-	2
48"	1520022W	-	2
513mm	1620022W	1620222W	1
1000mm	1720022W	-	2



up to 24" wide



30" and wider

Width	Right Hinged	Left Hinged	# of Doors
12"	1020033W	1020233W	1
15"	1920033W	1920233W	1
18"	1120033W	1120233W	1
24"	1220033W	1220233W	1
30"	1320033W	-	2
36"	1420033W	-	2
42"	1820033W	-	2
48"	1520033W	-	2
513mm	1620033W	1620233W	1
1000mm	1720033W	-	2



Width	Item Number
30"	1320093W
36"	1420093W
42"	1820093W
48"	1520093W
1000mm	1720093W



Width	Item Number
30"	1320096W
36"	1420096W
42"	1820096W
48"	1520096W
1000mm	1720096W

BASE CABINETS

28-3/4" HIGH X 22" DEEP

Door/Drawer Units



Width	Right Hand	Left Hand
30"	1320032W	1320023W
36"	1420032W	1420023W
42"	1820032W	1820023W
48"	1520032W	1520023W
1000mm	1720032W	1720023W

- Left hand door/drawer unit shown.
- Right hand reversed.



Width	Right Hand	Left Hand
30"	1320021W	1320012W
36"	1420021W	1420012W
42"	1820021W	1820012W
48"	1520021W	1520012W
1000mm	1720021W	1720012W

- Left hand door/drawer unit shown.
- Right hand reversed.



Width	Right Hand	Left Hand
30"	1320031W	1320013W
36"	1420031W	1420013W
42"	1820031W	1820013W
48"	1520031W	1520013W
1000mm	1720031W	1720013W

- Left hand door/drawer unit shown.
- Right hand reversed.



Width	Right Hand	Left Hand
30"	1320041W	1320014W
36"	1420041W	1420014W
42"	1820041W	1820014W
48"	1520041W	1520014W
1000mm	1720041W	1720014W

- Left hand door/drawer unit shown.
- Right hand reversed.



Width	Right Hand	Left Hand
30"	1320051W	1320015W
36"	1420051W	1420015W
42"	1820051W	1820015W
48"	1520051W	1520015W
1000mm	1720051W	1720015W

- Left hand door/drawer unit shown.
- Right hand reversed.



Width	Right Hand	Left Hand
30"	1320061W	1320016W
36"	1420061W	1420016W
42"	1820061W	1820016W
48"	1520061W	1520016W
1000mm	1720061W	1720016W

- Left hand door/drawer unit shown.
- Right hand reversed.



Width	Right Hand	Left Hand
30"	1320942W	1320924W
36"	1420942W	1420924W
42"	1820942W	1820924W
48"	1520942W	1520924W
1000mm	1720942W	1720924W

- Left hand door/drawer unit shown.
- Right hand reversed.



Width	Right Hand	Left Hand
30"	1320042W	1320024W
36"	1420042W	1420024W
42"	1820042W	1820024W
48"	1520042W	1520024W
1000mm	1720042W	1720024W

- Left hand door/drawer unit shown.
- Right hand reversed.



Width	Right Hand	Left Hand
30"	1320052W	1320025W
36"	1420052W	1420025W
42"	1820052W	1820025W
48"	1520052W	1520025W
1000mm	1720052W	1720025W

- Left hand door/drawer unit shown.
- Right hand reversed.



Width	Right Hand	Left Hand
30"	1320062W	1320026W
36"	1420062W	1420026W
42"	1820062W	1820026W
48"	1520062W	1520026W
1000mm	1720062W	1720026W

- Left hand door/drawer unit shown.
- Right hand reversed.

BASE CABINETS

28-3/4" HIGH X 22" DEEP

Door/Drawer Units



Width	Right Hand	Left Hand
30"	1320043W	1320034W
36"	1420043W	1420034W
42"	1820043W	1820034W
48"	1520043W	1520034W
1000mm	1720043W	1720034W

- Left hand door/drawer unit shown.
- Right hand reversed.



Width	Right Hand	Left Hand
30"	1320053W	1320035W
36"	1420053W	1420035W
42"	1820053W	1820035W
48"	1520053W	1520035W
1000mm	1720053W	1720035W

- Left hand door/drawer unit shown.
- Right hand reversed.



Width	Right Hand	Left Hand
30"	1320063W	1320036W
36"	1420063W	1420036W
42"	1820063W	1820036W
48"	1520063W	1520036W
1000mm	1720063W	1720036W

- Left hand door/drawer unit shown.
- Right hand reversed.

Drawer Units



up to 24" wide



30" and wider

Width	Item Number
15"	1920044W
18"	1120044W
24"	1220044W
30"	1320044W
36"	1420044W
42"	1820044W
48"	1520044W
513mm	1620044W
1000mm	1720044W



up to 24" wide



30" and wider

Width	Item Number
15"	1920055W
18"	1120055W
24"	1220055W
30"	1320055W
36"	1420055W
42"	1820055W
48"	1520055W
513mm	1620055W
1000mm	1720055W



up to 24" wide



30" and wider

Width	Item Number
15"	1920066W
18"	1120066W
24"	1220066W
30"	1320066W
36"	1420066W
42"	1820066W
48"	1520066W
513mm	1620066W
1000mm	1720066W

BASE CABINETS

28-3/4" HIGH X 22" DEEP

Drawer Units



Width	Item Number
30"	1320097W
36"	1420097W
42"	1820097W
48"	1520097W
1000mm	1720097W



Width	Item Number
30"	1320098W
36"	1420098W
42"	1820098W
48"	1520098W
1000mm	1720098W



Width	Item Number
30"	1320091W
36"	1420091W
42"	1820091W
48"	1520091W
1000mm	1720091W



Width	Item Number
30"	1320099W
36"	1420099W
42"	1820099W
48"	1520099W
1000mm	1720099W



Width	Item Number
30"	1320094W
36"	1420094W
42"	1820094W
48"	1520094W
1000mm	1720094W



Width	Item Number
30"	1320092W
36"	1420092W
42"	1820092W
48"	1520092W
1000mm	1720092W



Width	Item Number
30"	1320095W
36"	1420095W
42"	1820095W
48"	1520095W
1000mm	1720095W



Width	Item Number
30"	1320B44W
36"	1420B44W
42"	1820B44W
48"	1520B44W
1000mm	1720B44W

File Drawer Units



up to 24" wide



30" and wider

Width	Item Number
15"	1920122W
18"	1120122W
24"	1220122W
30"	1320122W
36"	1420122W
42"	1820122W
48"	1520122W
513mm	1620122W
1000mm	1720122W



up to 24" wide



30" and wider

Width	Item Number
15"	1920177W
18"	1120177W
24"	1220177W
30"	1320177W
36"	1420177W
42"	1820177W
48"	1520177W
513mm	1620177W
1000mm	1720177W

All dimensions and sizes shown are nominal. Specifications and details are based on product information at the time of printing and may change at any time without notice. Mott Manufacturing reserves the right to change dimensions, specifications and manufacturing details at any time without notice.

BASE CABINETS

28-3/4" HIGH X 22" DEEP

File Drawer Units



up to 24" wide



30" and wider

Width	Item Number
15"	1920188W
18"	1120188W
24"	1220188W
30"	1320188W
36"	1420188W
42"	1820188W
48"	1520188W
513mm	1620188W
1000mm	1720188W

Sliding Door Units



Width	Item Number
30"	1320711W
36"	1420711W
42"	1820711W
48"	1520711W
1000mm	1720711W

- Actual depth 7/8" less than nominal.

Waste/Storage Bin Units



up to 24" wide



30" and wider

Width	Item Number	# of Bins
15"	1920500W	1
18"	1120500W	1
24"	1220500W	1
30"	1320500W	2
36"	1420500W	2
42"	1820500W	2
48"	1520500W	2
513mm	1620500W	1
1000mm	1720500W	2

- Add option code 84 to order galvanized waste/storage bin.
- Tilt out door is hinged at the bottom.

Corner Units

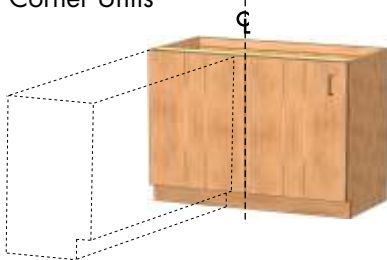

Width	Door on Right	Door on Left
30"	1320311W	1320411W
36"	1420311W	1420411W
42"	1820311W	1820411W
48"	1520311W	1520411W
1000mm	1720311W	1720411W

- Right door corner unit shown.
- Left door corner unit reversed.
- Center stile is located at the middle point.

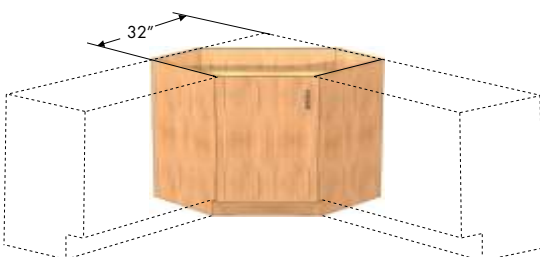

Description	Right Hinged	Left Hinged
Full Door Unit	1027011W	1027111W
False Panel Unit	1027422W	1027922W

- Left hinge, full door corner unit shown.
- Overall depth of this unit is 22-3/4" from the front of the door to the back of the cabinet.
- Add option code 89 to order a lazy susan.

BASE CABINETS

28-3/4" HIGH X 22" DEEP

Sink Units



up to 24" wide



30" and wider



up to 24" wide



30" and wider

Width	Right Hinged	Left Hinged	# of Doors
12"	1023011W	1023211W	1
15"	1923011W	1923211W	1
18"	1123011W	1123211W	1
24"	1223011W	1223211W	1
30"	1323011W	-	2
36"	1423011W	-	2
42"	1823011W	-	2
48"	1523011W	-	2
513mm	1623011W	1623211W	1
1000mm	1723011W	-	2

- Add Option Code 90 to order Sink Hanger Supports.

Width	Right Hinged	Left Hinged	# of Doors
12"	1028022W	1028222W	1
15"	1928022W	1928222W	1
18"	1128022W	1128222W	1
24"	1228022W	1228222W	1
30"	1328022W	-	2
36"	1428022W	-	2
42"	1828022W	-	2
48"	1528022W	-	2
513mm	1628022W	1628222W	1
1000mm	1728022W	-	2

- Add option code 90 to order Sink Hanger Supports.

End Sink Units



Description	54" Wide	58" Wide
Full Door Unit	9900019W	9900020W
False Panel Unit	9900023W	9900024W

- Full Door End Sink Unit shown.
- Add option code 90 to order Sink Hanger Supports.

Description	54" Wide	58" Wide
Full Door Unit	9980319W	9980320W

- Full Door End Sink Unit shown.
- Add option code 90 to order Sink Hanger Supports.

Sink Support Kit



Width	18" Deep Cabinet	22" Deep Cabinet
12"	SSW0012	SSW1012
15"	SSW0015	SSW1015
18"	SSW0018	SSW1018
24"	SSW0024	SSW1024
30"	SSW0030	SSW1030
36"	SSW0036	SSW1036
42"	SSW0042	SSW1042
48"	SSW0048	SSW1048
54"	SSW0054	SSW1054
58"	SSW0058	SSW1058

Description	Corner Sink Unit
Corner Unit	SSW0000

- Metal frame to support and position an undermount sink.
- Sink Support Kit for corner unit not exactly as shown.

BASE CABINETS

31-3/4" HIGH X 22" DEEP

Open Units



Width	Item Number
12"	108000W
15"	198000W
18"	118000W
24"	128000W
30"	138000W
36"	148000W
42"	188000W
48"	158000W
513mm	168000W
1000mm	178000W

• Actual depths 7/8" less than nominal.

Full Door Units



up to 24" wide



30" and wider

Width	Right Hinged	Left Hinged	# of Doors
12"	1080011W	1080211W	1
15"	1980011W	1980211W	1
18"	1180011W	1180211W	1
24"	1280011W	1280211W	1
30"	1380011W	-	2
36"	1480011W	-	2
42"	1880011W	-	2
48"	1580011W	-	2
513mm	1680011W	1680211W	1
1000mm	1780011W	-	2

Door/Drawer Units



up to 24" wide



30" and wider

Width	Right Hinged	Left Hinged	# of Doors
12"	1080022W	1080222W	1
15"	1980022W	1980222W	1
18"	1180022W	1180222W	1
24"	1280022W	1280222W	1
30"	1380022W	-	2
36"	1480022W	-	2
42"	1880022W	-	2
48"	1580022W	-	2
513mm	1680022W	1680222W	1
1000mm	1780022W	-	2



Width	Item Number
30"	1380093W
36"	1480093W
42"	1880093W
48"	1580093W
1000mm	1780093W



Width	Right Hand	Left Hand
30"	1380942W	1380924W
36"	1480942W	1480924W
42"	1880942W	1880924W
48"	1580942W	1580924W
1000mm	1780942W	1780924W

• Left hand door/drawer unit shown.
• Right hand reversed.



Width	Right Hand	Left Hand
30"	1380042W	1380024W
36"	1480042W	1480024W
42"	1880042W	1880024W
48"	1580042W	1580024W
1000mm	1780042W	1780024W

• Left hand door/drawer unit shown.
• Right hand reversed.

BASE CABINETS

31-3/4" HIGH X 22" DEEP

Drawer Units



up to 24" wide



30" and wider

Width	Item Number
15"	1980090W
18"	1180090W
24"	1280090W
30"	13800NNW
36"	14800NNW
42"	18800NNW
48"	15800NNW
513mm	1680090W
1000mm	17800NNW



up to 24" wide



30" and wider

Width	Item Number
12"	1080044W
15"	1980044W
18"	1180044W
24"	1280044W
30"	1380044W
36"	1480044W
42"	1880044W
48"	1580044W
513mm	1680044W
1000mm	1780044W



up to 24" wide



30" and wider

Width	Item Number
15"	1980055W
18"	1180055W
24"	1280055W
30"	1380055W
36"	1480055W
42"	1880055W
48"	1580055W
513mm	1680055W
1000mm	1780055W



Width	Item Number
30"	1380090W
36"	1480090W
42"	1880090W
48"	1580090W
1000mm	1780090W



Width	Item Number
30"	1380097W
36"	1480097W
42"	1880097W
48"	1580097W
1000mm	1780097W



Width	Item Number
30"	1380099W
36"	1480099W
42"	1880099W
48"	1580099W
1000mm	1780099W

BASE CABINETS

31-3/4" HIGH X 22" DEEP

File Drawer Units



up to 24" wide



30" and wider

Width	Item Number
15"	1980100W
18"	1180100W
24"	1280100W
30"	1380100W
36"	1480100W
42"	1880100W
48"	1580100W
513mm	1680100W
1000mm	1780100W



up to 24" wide



30" and wider

Width	Item Number
15"	1980111W
18"	1180111W
24"	1280111W
30"	1380111W
36"	1480111W
42"	1880111W
48"	1580111W
513mm	1680111W
1000mm	1780111W

Sliding Door Units



Width	Item Number
30"	1380711W
36"	1480711W
42"	1880711W
48"	1580711W
1000mm	1780711W

• Actual depth 7/8" less than nominal.

Sink Units



up to 24" wide



30" and wider

Width	Right Hinged	Left Hinged	# of Doors
12"	1083011W	1083211W	1
15"	1983011W	1983211W	1
18"	1183011W	1183211W	1
24"	1283011W	1283211W	1
30"	1383011W	-	2
36"	1483011W	-	2
42"	1883011W	-	2
48"	1583011W	-	2
513mm	1683011W	1683211W	1
1000mm	1783011W	-	2

• Add option code 90 to order Sink Hanger Supports.



up to 24" wide



30" and wider

Width	Right Hinged	Left Hinged	# of Doors
12"	1088022W	1088222W	1
15"	1988022W	1988222W	1
18"	1188022W	1188222W	1
24"	1288022W	1288222W	1
30"	1388022W	-	2
36"	1488022W	-	2
42"	1888022W	-	2
48"	1588022W	-	2
513mm	1688022W	1688222W	1
1000mm	1788022W	-	2

BASE CABINETS

31-3/4" HIGH X 22" DEEP

End Sink Units



Description	54" Wide	58" Wide
Full Door Unit	9980017W	9980018W
False Panel Unit	9980021W	9980022W

- Full Door End Sink Unit shown.
- Add option code 90 to order Sink Hanger Supports.

Description	54" Wide	58" Wide
Full Door Unit	9980317W	9980318W

- Full Door End Sink Unit shown.
- Add option code 90 to order Sink Hanger Supports.

Corner Sink Units

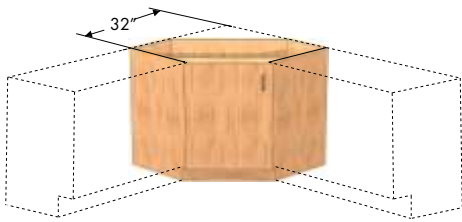

Description	Right Hinged	Left Hinged
Full Door Unit	1087211W	1087511W
False Panel Unit	1087722W	1087622W

- Left Hinge, Corner Sink Unit shown.
- Overall depth of this unit is 22-3/4" from the front of the door to the back of the cabinet.
- Add option code 90 to order Sink Hanger Supports.

Pocket Door Sink Units



Base bottom in down position

Base bottom in knee space position

Width	Item Number
30"	138KS22W
36"	148KS22W
42"	188KS22W
48"	158KS22W
1000mm	178KS22W

- Incorporates pocket doors and fold-up base to convert from sink cabinet design to knee space design.

BASE CABINETS

31-3/4" HIGH X 22" DEEP

Knee Space Sink Cabinets

- Gable Legs are 3/4".
- Knee Space ships unassembled.
- Accommodates a 6" deep sink.
- 30" wide cabinets are not ADA compliant.
- See dotted line in figure to the right for ADA requirements.

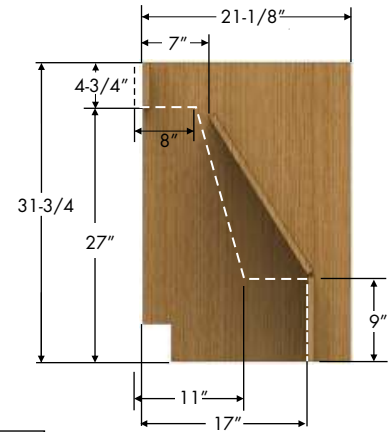

Note: Dotted line represents ADA requirements.



Width	Item Number
30"	13K3011W
33"	13K3311W
36"	14K3011W
42"	18K3011W
48"	15K3011W
1000mm	17K3011W



Width	Item Number
30"	13KP011W
36"	14KP011W
42"	18KP011W
48"	15KP011W
1000mm	17KP011W



Width	Item Number
30"	13KL011W
36"	14KL011W
42"	18KL011W
48"	15KL011W
1000mm	17KL011W



Width	Item Number
30"	13KR011W
36"	14KR011W
42"	18KR011W
48"	15KR011W
1000mm	17KR011W

BASE CABINETS OPTIONS

Option Code	Description
00	Modified door/drawer configuration
02	Label holders on all doors/drawers
03	Numeric or alpha identification disks on all doors/drawers (customer details required)
04	Standard louver configuration on doors (6 louvers at 3" wide x 5-1/2" long)
05	Non-standard louver configuration on doors (customer drawing required)
07	Cut-outs for electrical and/or plumbing services (customer drawing required)
08	Security proof panel
09	Stainless steel waste flap
10	One fixed drawer divider per drawer (centered in drawer)
11	Multiple drawer dividers per drawer (customer drawing required)
12	Pull out writing board - all cold rolled steel*
13	Pull out writing board - cold rolled steel & high pressure laminate writing surface*
14	Ventilation grill in toe kick base
15	Finished back on cabinet
16	Ship handles not installed
17	Nylon levelers
18	Horizontally mounted handles
19	Full width drawer on 5" high apron
26	200 lbs full extension drawer runners
40	One extra cabinet shelf
41	Two extra cabinet shelves
42	One interior cabinet shelf on full extension runners (replaces fixed shelf)
43	Two interior cabinet shelves on full extension runners (replaces fixed shelf)
44	Three interior cabinet shelves on full extension runners (replaces fixed shelf)
48	Keyboard tray (replaces drawer)
70	Front toe kick
71	Toe kick - front & left side
72	Toe kick - front & right side
73	Toe kick - front & 2 sides
74	Toe kick - front & back
75	Toe kick - front, back & 2 sides
76	Replace toe kick with 4 legs
77	Replace toe kick with 4 casters
78	Replace toe kick with customer specified casters
79	Other customer specified base or toe kick
84	Stainless steel bin insert
85	PVC bin insert
89	Lazy susan storage unit for corner cabinets
90	Sink supports - for under counter mounted sinks
AD	Add - a - drawer design (6" high construction)
C25	Replace toe kick with caster, 250lbs each
DC2	Magnetic Door Catch
F2	Welded finished top and back
F26	File drawer on 200lb full extension runners
101	Full extension runners with interlock
126	200lbs full extension runners with interlock
LA	Bilingual label (French/English)
LF	Longitudinal file
NB	No base, on cabinet to sit on floor, levelers included
NC	No base, on cabinet to sit on 4" high curb, levelers not included
NF	No cabinet floor and toe kick is integral with door
OLD	Actual depth
PC	Foot pedal cutouts centered
PL	Foot pedal cutout left hand side
PR	Foot pedal cutout right hand side
PW	Pre-wired (option code not to be used for fume hoods) (customer details required)

BASE CABINET OPTIONS

Option Code	Description
PFE	Pull out writing board on full extension runners*
RB	Removable back on drawer cabinet
SK	Skid item
S01	Full extension soft close drawer runners
S26	200lbs full extension soft close drawers runners
T1	Replace one shelf with one pull out tray on full extension runners with 2" high lip
T2	Replace two shelves with two pull out trays on full extension runners with 2" high lip
T3	Replace three shelves with three pull out trays on full extension runners with 2" high lip

Notes: *30" wide cabinets and above receive 2 pull out writing boards unless it's a full width drawer cabinet.

WALL CABINETS

24" HIGH X 14" DEEP

Open Units



Width	Item Number
18"	5170010W
24"	5270010W
30"	5370010W
36"	5470010W
42"	5670010W
48"	5570010W
513mm	5970010W
1000mm	5870010W

• Actual depth 7/8" less than nominal.

Hinged Framed Door Units



up to 24" wide



30" and wider

Width	Right Hinged	Left Hinged	# of Doors
18"	5170030W	5171030W	1
24"	5270030W	5271030W	1
30"	5370030W	-	2
36"	5470030W	-	2
42"	5670030W	-	2
48"	5570030W	-	2
513mm	5970030W	5971030W	1
1000mm	5870030W	-	2

Hinged Door Units



up to 24" wide



30" and wider

Width	Right Hinged	Left Hinged	# of Doors
18"	5170060W	5171060W	1
24"	5270060W	5271060W	1
30"	5370060W	-	2
36"	5470060W	-	2
42"	5670060W	-	2
48"	5570060W	-	2
513mm	5970060W	5971060W	1
1000mm	5870060W	-	2

Sliding Glass Door Units



Width	Item Number
30"	5370020W
36"	5470020W
42"	5670020W
48"	5570020W
1000mm	5870020W

• Actual depth 7/8" less than nominal.

Sliding Framed Door Units



Width	Item Number
30"	5370040W
36"	5470040W
42"	5670040W
48"	5570040W
1000mm	5870040W

• Actual depth 7/8" less than nominal.

Sliding Door Units



Width	Item Number
30"	5370050W
36"	5470050W
42"	5670050W
48"	5570050W
1000mm	5870050W

• Actual depth 7/8" less than nominal.

Hinged Framed Door Corner Units



Width	Door on Right	Door on Left
30"	5370330W	5370430W
36"	5470330W	5470430W
42"	5670330W	5670430W
48"	5570330W	5570430W
1000mm	5870330W	5870430W

• Right door corner unit shown. Left door reversed.

• Blind portion of cabinet is 14" wide on these units.

WALL CABINETS

24" HIGH X 14" DEEP

Hinged Door Corner Units



Width	Door on Right	Door on Left
30"	5370360W	5370460W
36"	5470360W	5470460W
42"	5670360W	5670460W
48"	5570360W	5570460W
1000mm	5870360W	5870460W

- Right door corner unit shown. Left door reversed.
- Blind portion of cabinet is 14" wide on these units.

WALL CABINETS

30" HIGH X 14" DEEP

Open Units



Width	Item Number
18"	5110010W
24"	5210010W
30"	5310010W
36"	5410010W
42"	5610010W
48"	5510010W
513mm	5910010W
1000mm	5810010 W

- Actual depth is 7/8" less than nominal.

Hinged Framed Door Units



up to 24" wide



30" and wider

Width	Right Hinged	Left Hinged	# of Doors
18"	5110030W	5111030W	1
24"	5210030W	5211030W	1
30"	5310030W	-	2
36"	5410030W	-	2
42"	5610030W	-	2
48"	5510030W	-	2
513mm	5910030W	5911030W	1
1000mm	5810030W	-	2

Hinged Door Units



up to 24" wide



30" and wider

Width	Right Hinged	Left Hinged	# of Doors
18"	5110060W	5111060W	1
24"	5210060W	5211060W	1
30"	5310060W	-	2
36"	5410060W	-	2
42"	5610060W	-	2
48"	5510060W	-	2
513mm	5910060W	5911060W	1
1000mm	5810060W	-	2

Sliding Glass Door Units



Width	Item Number
30"	5310020W
36"	5410020W
42"	5610020W
48"	5510020W
1000mm	5810020W

- Actual depth 7/8" less than nominal.

Sliding Framed Glass Door Units



Width	Item Number
30"	5310040W
36"	5410040W
42"	5610040W
48"	5510040W
1000mm	5810040W

- Actual depth 7/8" less than nominal.

WALL CABINETS

30" HIGH X 14" DEEP

Sliding Door Units



Width	Item Number
30"	5310050W
36"	5410050W
42"	5610050W
48"	5510050W
1000mm	5810050W

- Actual depth 7/8" less than nominal.

Hinged Framed Door Corner Units



Width	Door on Right	Door on Left
30"	5310330W	5310430W
36"	5410330W	5410430W
42"	5610330W	5610430W
48"	5510330W	5510430W
1000mm	5810330W	5810430W

- Right door corner unit shown. Left door reversed.
- Blind portion of cabinet is 14" wide on these units.

Hinged Door Corner Units

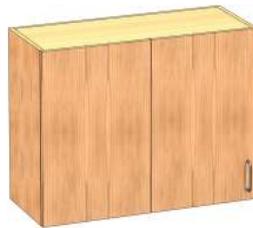

Width	Door on Right	Door on Left
30"	5310360W	5310460W
36"	5410360W	5410460W
42"	5610360W	5610460W
48"	5510360W	5510460W
1000mm	5810360W	5810460W

- Right door corner unit shown. Left door reversed.
- Blind portion of cabinet is 14" wide on these units.

WALL CABINETS

36" HIGH X 14" DEEP

Open Units



Width	Item Number
18"	5120010W
24"	5220010W
30"	5320010W
36"	5420010W
42"	5620010W
48"	5520010W
513mm	5920010W
1000mm	5820010W

- Actual depth 7/8" less than nominal.

Hinged Framed Glass Door Units



up to 24" wide



30" and wider

Width	Right Hinged	Left Hinged	# of Doors
18"	5120030W	5121030W	1
24"	5220030W	5221030W	1
30"	5320030W	-	2
36"	5420030W	-	2
42"	5620030W	-	2
48"	5520030W	-	2
513mm	5920030W	5921030W	1
1000mm	5820030W	-	2

Hinged Door Units



up to 24" wide



30" and wider

Width	Right Hinged	Left Hinged	# of Doors
18"	5120060W	5121060W	1
24"	5220060W	5221060W	1
30"	5320060W	-	2
36"	5420060W	-	2
42"	5620060W	-	2
48"	5520060W	-	2
513mm	5920060W	5921060W	1
1000mm	5820060W	-	2

WALL CABINETS

36" HIGH X 14" DEEP

Sliding Glass Door Units



Width	Item Number
30"	5320020W
36"	5420020W
42"	5620020W
48"	5520020W
1000mm	5820020W

- Actual depth 7/8" less than nominal.

Sliding Framed Door Units



Width	Item Number
30"	5320040W
36"	5420040W
42"	5620040W
48"	5520040W
1000mm	5820040W

- Actual depth 7/8" less than nominal.

Sliding Door Units



Width	Item Number
30"	5320050W
36"	5420050W
42"	5620050W
48"	5520050W
1000mm	5820050W

- Actual depth 7/8" less than nominal.

Hinged Framed Door Corner Units



Width	Door on Right	Door on Left
30"	5320330W	5320430W
36"	5420330W	5420430W
42"	5620330W	5620430W
48"	5520330W	5520430W
1000mm	5820330W	5820430W

- Right door corner unit shown. Left door reversed.
- Blind portion of cabinet is 14" wide on these units.

Hinged Door Corner Units

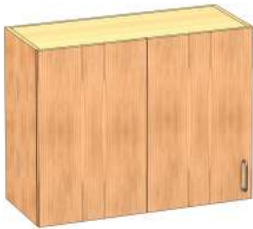

Width	Door on Right	Door on Left
30"	5320360W	5320460W
36"	5420360W	5420460W
42"	5620360W	5620460W
48"	5520360W	5520460W
1000mm	5820360W	5820460W

- Right door corner unit shown. Left door reversed.
- Blind portion of cabinet is 14" wide on these units.

WALL CABINETS

48" HIGH X 14" DEEP

Open Units



Width	Item Number
18"	5130010W
24"	5230010W
30"	5330010W
36"	5430010W
42"	5630010W
48"	5530010W
513mm	5930010W
1000mm	5830010W

- Actual depth 7/8" less than nominal.

WALL CABINETS

48" HIGH X 14" DEEP

Hinged Framed Door Units



Width	Right Hinged	Left Hinged	# of Doors
18"	5130030W	5131030W	1
24"	5230030W	5231030W	1
30"	5330030W	-	2
36"	5430030W	-	2
42"	5630030W	-	2
48"	5530030W	-	2
513mm	5930030W	5931030W	1
1000mm	5830030W	-	2

up to 24" wide

30" and wider

Hinged Door Units



Width	Right Hinged	Left Hinged	# of Doors
18"	5130060W	5131060W	1
24"	5230060W	5231060W	1
30"	5330060W	-	2
36"	5430060W	-	2
42"	5630060W	-	2
48"	5530060W	-	2
513mm	5930060W	5931060W	1
1000mm	5830060W	-	2

up to 24" wide

30" and wider

Sliding Glass Door Units



Width	Item Number
30"	5330020W
36"	5430020W
42"	5630020W
48"	5530020W
1000mm	5830020W

- Actual depth 7/8" less than nominal.

Sliding Framed Door Units



Width	Item Number
30"	5330040W
36"	5430040W
42"	5630040W
48"	5530040W
1000mm	5830040W

- Actual depth 7/8" less than nominal.

Sliding Door Units



Width	Item Number
30"	5330050W
36"	5430050W
42"	5630050W
48"	5530050W
1000mm	5830050W

- Actual depth 7/8" less than nominal.

Hinged Framed Door Corner Units



Width	Door on Right	Door on Left
30"	5330330W	5330430W
36"	5430330W	5430430W
42"	5630330W	5630430W
48"	5530330W	5530430W
1000mm	5830330W	5830430W

- Right door corner unit shown. Left door reversed.
- Blind portion of cabinet is 14" wide on these units.

WALL CABINETS

48" HIGH X 14" DEEP

Hinged Door Corner Units



Width	Door on Right	Door on Left
30"	5330360W	5330460W
36"	5430360W	5430460W
42"	5630360W	5630460W
48"	5530360W	5530460W
1000mm	5830360W	5830460W

- Right door corner unit shown. Left door reversed.
- Blind portion of cabinet is 14" wide on these units.

WALL CABINETS

24" HIGH X 18" DEEP

Open Units



Width	Item Number
18"	5180010W
24"	5280010W
30"	5380010W
36"	5480010W
42"	5680010W
48"	5580010W
513mm	5980010W
1000mm	5880010W

- Actual depth 7/8" less than nominal.

Hinged Framed Door Units



up to 24" wide



30" and wider

Width	Right Hinged	Left Hinged	# of Doors
18"	5180030W	5181030W	1
24"	5280030W	5281030W	1
30"	5380030W	-	2
36"	5480030W	-	2
42"	5680030W	-	2
48"	5580030W	-	2
513mm	5980030W	5981030W	1
1000mm	5880030W	-	2

Hinged Door Units



up to 24" wide



30" and wider

Width	Right Hinged	Left Hinged	# of Doors
18"	5180060W	5181060W	1
24"	5280060W	5281060W	1
30"	5380060W	-	2
36"	5480060W	-	2
42"	5680060W	-	2
48"	5580060W	-	2
513mm	5980060W	5981060W	1
1000mm	5880060W	-	2

Sliding Glass Door Units



Width	Item Number
30"	5380020W
36"	5480020W
42"	5680020W
48"	5580020W
1000mm	5880020W

- Actual depth 7/8" less than nominal.

Sliding Framed Door Units



Width	Item Number
30"	5380040W
36"	5480040W
42"	5680040W
48"	5580040W
1000mm	5880040W

- Actual depth 7/8" less than nominal.

WALL CABINETS

24" HIGH X 18" DEEP

Sliding Door Units



Width	Item Number
30"	5380050W
36"	5480050W
42"	5680050W
48"	5580050W
1000mm	5880050W

- Actual depth is 7/8" less than nominal.

Hinged Framed Door Corner Units



Width	Door on Right	Door on Left
30"	5380330W	5380430W
36"	5480330W	5480430W
42"	5680330W	5680430W
48"	5580330W	5580430W
1000mm	5880330W	5880430W

- Right door corner unit shown. Left door reversed.
- Blind portion of cabinet is 18" wide on these units.

Hinged Door Corner Units



Width	Door on Right	Door on Left
30"	5380360W	5380460W
36"	5480360W	5480460W
42"	5680360W	5680460W
48"	5580360W	5580460W
1000mm	5880360W	5880460W

- Right door corner unit shown. Left door reversed.
- Blind portion of cabinet is 18" wide on these units.

WALL CABINETS

30" HIGH X 18" DEEP

Open Units



Width	Item Number
18"	5140010W
24"	5240010W
30"	5340010W
36"	5440010W
42"	5640010W
48"	5540010W
513mm	5940010W
1000mm	5840010W

- Actual depth 7/8" less than nominal.

Hinged Framed Door Units



up to 24" wide



30" and wider

Width	Right Hinged	Left Hinged	# of Doors
18"	5140030W	5141030W	1
24"	5240030W	5241030W	1
30"	5340030W	-	2
36"	5440030W	-	2
42"	5640030W	-	2
48"	5540030W	-	2
513mm	5940030W	5941030W	1
1000mm	5840030W	-	2

Hinged Door Units



up to 24" wide



30" and wider

Width	Right Hinged	Left Hinged	# of Doors
18"	5140060W	5141060W	1
24"	5240060W	5241060W	1
30"	5340060W	-	2
36"	5440060W	-	2
42"	5640060W	-	2
48"	5540060W	-	2
513mm	5940060W	5941060W	1
1000mm	5840060W	-	2

WALL CABINETS

30" HIGH X 18" DEEP

Sliding Glass Door Units



Width	Item Number
30"	5340020W
36"	5440020W
42"	5640020W
48"	5540020W
1000mm	5840020W

- Actual depth 7/8" less than nominal.

Sliding Framed Door Units



Width	Item Number
30"	5340040W
36"	5440040W
42"	5640040W
48"	5540040W
1000mm	5840040W

- Actual depth 7/8" less than nominal.

Sliding Door Units



Width	Item Number
30"	5340050W
36"	5440050W
42"	5640050W
48"	5540050W
1000mm	5840050W

- Actual depth 7/8" less than nominal.

Hinged Framed Door Corner Units



Width	Door on Right	Door on Left
30"	5340330W	5340430W
36"	5440330W	5440430W
42"	5640330W	5640430W
48"	5540330W	5540430W
1000mm	5840330W	5840430W

- Right door corner unit shown. Left door reversed.
- Blind portion of cabinet is 18" wide on these units.

Hinged Door Corner Units



Width	Door on Right	Door on Left
30"	5340360W	5340460W
36"	5440360W	5440460W
42"	5640360W	5640460W
48"	5540360W	5540460W
1000mm	5840360W	5840460W

- Right door corner unit shown. Left door reversed.
- Blind portion of cabinet is 18" wide on these units.

WALL CABINETS

36" HIGH X 18" DEEP

Open Units



Width	Item Number
18"	5150010W
24"	5250010W
30"	5350010W
36"	5450010W
42"	5650010W
48"	5550010W
513mm	5950010W
1000mm	5850010W

- Actual depth 7/8" less than nominal.

Hinged Framed Door Units



Width	Right Hinged	Left Hinged	# of Doors
18"	5150030W	5151030W	1
24"	5250030W	5251030W	1
30"	5350030W	-	2
36"	5450030W	-	2
42"	5650030W	-	2
48"	5550030W	-	2
513mm	5950030W	5951030W	1
1000mm	5850030W	-	2

up to 24" wide

30" and wider

WALL CABINETS

36" HIGH X 18" DEEP

Hinged Door Units



up to 24" wide



30" and wider

Width	Right Hinged	Left Hinged	# of Doors
18"	5150060W	5151060W	1
24"	5250060W	5251060W	1
30"	5350060W	-	2
36"	5450060W	-	2
42"	5650060W	-	2
48"	5550060W	-	2
513mm	5950060W	5951060W	1
1000mm	5850060W	-	2

Sliding Glass Door Units



Width	Item Number
30"	5350020W
36"	5450020W
42"	5650020W
48"	5550020W
1000mm	5850020W

- Actual depth 7/8" less than nominal.

Sliding Framed Door Units



Width	Item Number
30"	5350040W
36"	5450040W
42"	5650040W
48"	5550040W
1000mm	5850040W

- Actual depth 7/8" less than nominal.

Sliding Door Units



Width	Item Number
30"	5350050W
36"	5450050W
42"	5650050W
48"	5550050W
1000mm	5850050W

- Actual depth 7/8" less than nominal.

Hinged Framed Door Corner Units



Width	Door on Right	Door on Left
30"	5350330W	5350430W
36"	5450330W	5450430W
42"	5650330W	5650430W
48"	5550330W	5550430W
1000mm	5850330W	5850430W

- Right door corner unit shown. Left door reversed.
- Blind portion of cabinet is 18" wide on these units.

Hinged Door Corner Units



Width	Door on Right	Door on Left
30"	5350360W	5350460W
36"	5450360W	5450460W
42"	5650360W	5650460W
48"	5550360W	5550460W
1000mm	5850360W	5850460W

- Right door corner unit shown. Left door reversed.
- Blind portion of cabinet is 18" wide on these units.

WALL CABINETS

48" HIGH X 18" DEEP

Open Units



Width	Item Number
18"	5160010W
24"	5260010W
30"	5360010W
36"	5460010W
42"	5660010W
48"	5560010W
513mm	5960010W
1000mm	5860010W

- Actual depth 7/8" less than nominal.

WALL CABINETS

48" HIGH X 18" DEEP

Hinged Framed Door Units



up to 24" wide

30" and wider

Width	Right Hinged	Left Hinged	# of Doors
18"	5160030W	5161030W	1
24"	5260030W	5261030W	1
30"	5360030W	-	2
36"	5460030W	-	2
42"	5660030W	-	2
48"	5560030W	-	2
513mm	5960030W	5961030W	1
1000mm	5860030W	-	2

Hinged Door Units

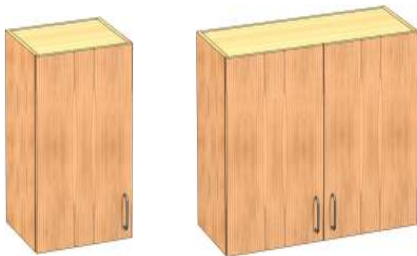

up to 24" wide

30" and wider

Width	Right Hinged	Left Hinged	# of Doors
18"	5160060W	5161060W	1
24"	5260060W	5261060W	1
30"	5360060W	-	2
36"	5460060W	-	2
42"	5660060W	-	2
48"	5560060W	-	2
513mm	5960060W	5961060W	1
1000mm	5860060W	-	2

Sliding Glass Door Units



Width	Item Number
30"	5360020W
36"	5460020W
42"	5660020W
48"	5560020W
1000mm	5860020W

- Actual depth 7/8" less than nominal.

Sliding Framed Door Units



Width	Item Number
30"	5360040W
36"	5460040W
42"	5660040W
48"	5560040W
1000mm	5860040W

- Actual depth 7/8" less than nominal.

Sliding Door Units



Width	Item Number
30"	5360050W
36"	5460050W
42"	5660050W
48"	5560050W
1000mm	5860050W

- Actual depth 7/8" less than nominal.

Hinged Framed Door Corner Units



Width	Door on Right	Door on Left
30"	5360330W	5360430W
36"	5460330W	5460430W
42"	5660330W	5660430W
48"	5560330W	5560430W
1000mm	5860330W	5860430W

- Right door corner unit shown. Left door reversed.
- Blind portion of cabinet is 18" wide on these units.

Hinged Door Corner Units



Width	Door on Right	Door on Left
30"	5360360W	5360460W
36"	5460360W	5460460W
42"	5660360W	5660460W
48"	5560360W	5560460W
1000mm	5860360W	5860460W

- Right door corner unit shown. Left door reversed.
- Blind portion of cabinet is 18" wide on these units.

WALL CABINETS

14"/18" DEEP

Hinged Framed Door Corner Units

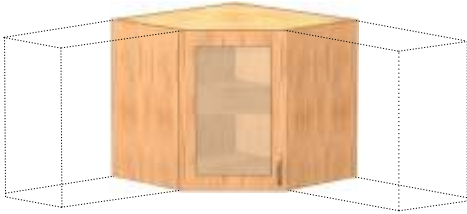

Width	Right Hinged	Left Hinged	Depth
24"	5070030W	5071030W	14"
30"	5010030W	5011030W	14"
36"	5020030W	5021030W	14"
48"	5030030W	5031030W	14"
24"	5080030W	5081030W	18"
30"	5040030W	5041030W	18"
36"	5050030W	5051030W	18"
48"	5060030W	5061030W	18"

Hinged Door Corner Units

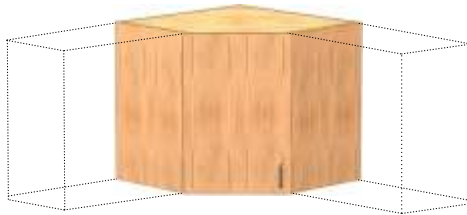

Width	Right Hinged	Left Hinged	Depth
24"	5070060W	5071060W	14"
30"	5010060W	5011060W	14"
36"	5020060W	5021060W	14"
48"	5030060W	5031060W	14"
24"	5080060W	5081060W	18"
30"	5040060W	5041060W	18"
36"	5050060W	5051060W	18"
48"	5060060W	5061060W	18"

Wall Cabinet Hanger Rails

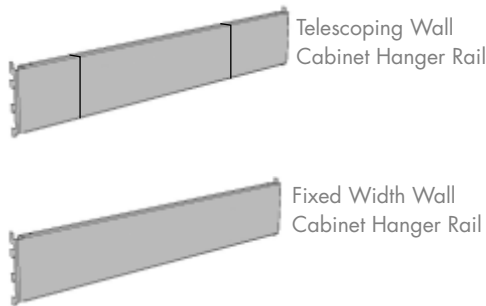

Width	Sigma Flex™		Sigma Frame™	
	Telescoping Rail	Fixed Width Rail	Telescoping Rail	Fixed Width Rail
24"	TWR0024	FWR0024	AWR0024	SWR0024
30"	TWR0030	FWR0030	AWR0030	SWR0030
36"	TWR0036	FWR0036	AWR0036	SWR0036
42"	TWA0042	FWR0042	AWA0042	SWR0042
48"	TWR0048	FWR0048	AWR0048	SWR0048
54"	TWR0054	FWR0054	AWR0054	SWR0054
60"	TWR0060	FWR0060	AWR0060	SWR0060
72"	TWR0072	FWR0072	AWR0072	SWR0072

- Wall Cabinet Hanger Rails are required to hang above-counter storage cabinets.
- Order rails to match width of support structure frame (Telescoping Rails are not suitable for cabinets smaller than 24" wide).
- Telescoping Rail is adjustable up to 5".
- Wall cabinets must be ordered with "J" Mounting Rails to hang on hanger rails.

Wall Cabinet "J" Mounting Rails



Width	Item Number
24"	JR00024
30"	JR00030
36"	JR00036
42"	JR00042
48"	JR00048
54"	JR00054
60"	JR00060
66"	JR00066
72"	JR00072

- A "J" Mounting Rail is required to hang metal above-counter storage cabinets on to Sigma Flex™ or Sigma Frame™ products.
- Order "J" rails to match width of support structure frame and Wall Cabinet Hanger Rail.
- "J" Rail ships loose.

WALL CABINET OPTIONS

Option Code	Description
00	Modified door/drawer configuration
02	Label holders on all doors/drawers
03	Numeric or alpha identification disks on all doors/drawers (customer details required)
09	Stainless steel waste flap
16	Ship handles not installed
18	Horizontally mounted handles
40	One extra cabinet shelf
41	Two extra cabinet shelves
45	DuoLite safety glass
46	Tempered glass
47	Customer specified glass
4A	Glass Tint 44% (Grey Smoke)
DS	Double sided wall cabinet
DC2	Magnetic door catch
OLD	Actual depth
SK	Skid item
SL	Seismic lip

FLOOR CABINETS

84" HIGH X 14" DEEP

Open Units



Width	Item Number
18"	6110010W
24"	6210010W
30"	6310010W
36"	6410010W
42"	6610010W
48"	6510010W
513mm	6910010W
1000mm	6810010W

- Actual depth 7/8" less than nominal.
- Fixed center shelf.

Hinged Framed Door Units



up to 24" wide

30" and wider

Width	Right Hinged	Left Hinged	# of Doors
18"	6110030W	6110230W	2
24"	6210030W	6210230W	2
30"	6310030W	-	4
36"	6410030W	-	4
42"	6610030W	-	4
48"	6510030W	-	4
513mm	6910030W	6910230W	2
1000mm	6810030W	-	4

- Add option code 80 to order full height doors.
- Fixed center shelf.

Hinged Door Units



up to 24" wide

30" and wider

Width	Right Hinged	Left Hinged	# of Doors
18"	6110060W	6110260W	2
24"	6210060W	6210260W	2
30"	6310060W	-	4
36"	6410060W	-	4
42"	6610060W	-	4
48"	6510060W	-	4
513mm	6910060W	6910260W	2
1000mm	6810060W	-	4

- Add option code 80 to order full height doors.
- Fixed center shelf.

Sliding Glass Door Units



Width	Item Number
30"	6310020W
36"	6410020W
42"	6610020W
48"	6510020W
1000mm	6810020W

- Add option code 80 to order full height doors.
- Fixed center shelf.
- Actual depth 7/8" less than nominal.

Sliding Framed Door Units



Width	Item Number
30"	6310040W
36"	6410040W
42"	6610040W
48"	6510040W
1000mm	6810040W

- Add option code 80 to order full height doors.
- Fixed center shelf.
- Actual depth 7/8" less than nominal.

FLOOR CABINETS

84" HIGH X 14" DEEP

Sliding Door Units



Width	Item Number
30"	6310050W
36"	6410050W
42"	6610050W
48"	6510050W
1000mm	6810050W

- Add option code 80 to order full height doors.
- Fixed center shelf.
- Actual depth is 7/8" less than nominal.

FLOOR CABINETS

84" HIGH X 18" DEEP

Open Units



Width	Item Number
18"	6120010W
24"	6220010W
30"	6320010W
36"	6420010W
42"	6620010W
48"	6520010W
513mm	6920010W
1000mm	6820010W

- Actual depth 7/8" less than nominal.
- Fixed center shelf

Hinged Framed Door Units



up to 24" wide

30" and wider

Width	Right Hinged	Left Hinged	# of Doors
18"	6120030W	6120230W	2
24"	6220030W	6220230W	2
30"	6320030W	-	4
36"	6420030W	-	4
42"	6620030W	-	4
48"	6520030W	-	4
513mm	6920030W	6920230W	2
1000mm	6820030W	-	4

- Add option code 80 to order full height doors.
- Fixed center shelf.

Hinged Door Units



up to 24" wide

30" and wider

Width	Right Hinged	Left Hinged	# of Doors
18"	6120060W	6120260W	2
24"	6220060W	6220260W	2
30"	6320060W	-	4
36"	6420060W	-	4
42"	6620060W	-	4
48"	6520060W	-	4
513mm	6920060W	6920260W	2
1000mm	6820060W	-	4

- Add option code 80 to order full height doors.
- Fixed center shelf.

FLOOR CABINETS

84" HIGH X 18" DEEP

Sliding Glass Door Units



Width	Item Number
30"	6320020W
36"	6420020W
42"	6620020W
48"	6520020W
1000mm	6820020W

- Add option code 80 to order full height doors.
- Fixed center shelf.
- Actual depth 7/8" less than nominal.

Sliding Framed Door Units



Width	Item Number
30"	6320040W
36"	6420040W
42"	6620040W
48"	6520040W
1000mm	6820040W

- Add option code 80 to order full height doors.
- Fixed center shelf.
- Actual depth 7/8" less than nominal.

Sliding Door Units



Width	Item Number
30"	6320050W
36"	6420050W
42"	6620050W
48"	6520050W
1000mm	6820050W

- Add option code 80 to order full height doors.
- Fixed center shelf.
- Actual depth is 7/8" less than nominal.

FLOOR CABINETS

84" HIGH X 22" DEEP

Open Units



Width	Item Number
18"	6130010W
24"	6230010W
30"	6330010W
36"	6430010W
42"	6630010W
48"	6530010W
513mm	6930010W
1000mm	6830010W

- Actual depth 7/8" less than nominal.
- Fixed center shelf

Hinged Framed Door Units



Width	Right Hinged	Left Hinged	# of Doors
18"	6130030W	6130230W	2
24"	6230030W	6230230W	2
30"	6330030W	-	4
36"	6430030W	-	4
42"	6630030W	-	4
48"	6530030W	-	4
513mm	6930030W	6930230W	2
1000mm	6830030W	-	4

- Add option code 80 to order full height doors.
- Fixed center shelf.

up to 24" wide

30" and wider

FLOOR CABINETS

84" HIGH X 22" DEEP

Hinged Door Units



up to 24" wide



30" and wider

Width	Right Hinged	Left Hinged	# of Doors
18"	6130060W	6130260W	2
24"	6230060W	6230260W	2
30"	6330060W	-	4
36"	6430060W	-	4
42"	6630060W	-	4
48"	6530060W	-	4
513mm	6930060W	6930260W	2
1000mm	6830060W	-	4

- Add option code 80 to order full height doors.
- Fixed center shelf.

Sliding Glass Door Units



Width	Item Number
30"	6330020W
36"	6430020W
42"	6630020W
48"	6530020W
1000mm	6830020W

- Add option code 80 to order full height doors.
- Fixed center shelf.
- Actual depth 7/8" less than nominal.

Sliding Framed Door Units



Width	Item Number
30"	6330040W
36"	6430040W
42"	6630040W
48"	6530040W
1000mm	6830040W

- Add option code 80 to order full height doors.
- Fixed center shelf.
- Actual depth 7/8" less than nominal.

Sliding Door Units



Width	Item Number
30"	6330050W
36"	6430050W
42"	6630050W
48"	6530050W
1000mm	6830050W

- Add option code 80 to order full height doors.
- Fixed center shelf.
- Actual depth is 7/8" less than nominal.

WARDROBE CABINETS

84" HIGH X 22" DEEP

Wardrobe Units



up to 24" wide



30" and wider

Width	Right Hinged	Left Hinged	# of Doors
15"	6A35060W	6A35260W	1
18"	6135060W	6135260W	1
24"	6235060W	6235260W	1
30"	6335060W	-	2
36"	6435060W	-	2
42"	6635060W	-	2
48"	6535060W	-	2

- Wardrobe Units have solid hinged double doors and include one stationary shelf and a clothes rod.
- Units must have a minimum depth of 22" to hold hangers.
- Mirror is not included.

WARDROBE CABINETS

84" HIGH X 22" DEEP

Wardrobe Units



Width	Item Number
30"	6335660W
36"	6435660W
42"	6635660W
48"	6535660W

- Wardrobe Units have solid hinged double doors and include one fixed shelf with attached clothes rod on the left side with one fixed top shelf and four adjustable shelves on the right side.
- Units must have a minimum depth of 22" to hold hangers.
- Mirror is not included.



Width	Item Number
30"	6335760W
36"	6435760W
42"	6635760W
48"	6535760W

- Wardrobe Units have solid hinged double doors and include one fixed shelf with attached clothes rod on the right side with one fixed top shelf and four adjustable shelves on the left side.
- Units must have a minimum depth of 22" to hold hangers.
- Mirror is not included.

INSTRUMENT STORAGE CABINETS

84" HIGH X 18" DEEP

Instrument Storage Units



up to 24" wide



30" and wider

Width	Right Hinged	Left Hinged	# of Doors
18"	61200A0W	61202A0W	2
24"	62200A0W	62202A0W	2
30"	63200A0W	-	4
36"	64200A0W	-	4
42"	66200A0W	-	4
48"	65200A0W	-	4
513mm	69200A0W	69202A0W	2
1000mm	68200A0W	-	4

- The upper section on the Instrument Storage Units have hinged framed glass doors with three adjustable shelves inside.
- The lower section is 34-3/4" high, with hinged solid doors and one adjustable shelf inside.



Width	Item Number
30"	63200B0W
36"	64200B0W
42"	66200B0W
48"	65200B0W
1000mm	68200B0W

- The upper section on the Instrument Storage Units have sliding framed glass doors with three adjustable shelves inside.
- The lower section is 34-3/4" high, with hinged solid doors, one adjustable shelf inside and two pull-out boards.



Width	Item Number
30"	63200C0W
36"	64200C0W
42"	66200C0W
48"	65200C0W
1000mm	68200C0W

- The upper section on the Instrument Storage Units have sliding framed glass doors with three adjustable shelves inside.
- The lower section is 34-3/4" high, with sliding solid doors, one adjustable shelf inside and two pull-out boards.

INSTRUMENT STORAGE CABINETS

84" HIGH X 18" DEEP

Instrument Storage Units



Width	Right Hinged	Left Hinged
24"	6227030W	6227230W

- 24" wide Instrument Storage Units have a hinged framed glass door with 15 compartments.
- Unit comes with four adjustable shelves.



Width	Item Number
36"	6427030W
48"	6527030W

- Instrument Storage Units have hinged framed glass double doors. 36" wide unit has 20 compartments. 48" wide unit has 30 compartments.
- Unit comes with four adjustable shelves.

TOTE TRAY STORAGE CABINETS

84" HIGH X 22" DEEP

Tote Tray Storage Units



Width	Item Number
48"	6530061W

- Holds 64 totes at 19" deep by 10-1/2" wide by 3-1/2" high.
- Fixed center shelf.
- Add option code 80 to order full height doors.
- Totes not included.



Item Number
PTT0001

- One piece, tan polystyrene tote.
- 19" deep by 10-1/2" wide by 3-1/2" high.
- Tote comes with label holder on front.



Width	Item Number
48"	6530062W

- Holds 48 totes at 19" deep by 13-3/4" wide by 4-3/8" high.
- Fixed center shelf.
- Add option code 80 to order full height doors.
- Totes not included.



Item Number
PTT0002

- One piece, tan polystyrene tote.
- 19-1/4" deep by 13-5/8" wide by 4-1/4" high.
- Tote comes with label holder on front.

FLOOR CABINET OPTIONS

Option Code	Description
00	Modified door/drawer configuration
02	Label holders on all doors/drawers
03	Numeric or alpha identification disks on all doors/drawers (customer details required)
04	Standard louver configuration on doors (6 louvers at 3" wide x 5-1/2" long)
05	Non-standard louver configuration on doors (customer drawing required)
07	Cut-outs for electrical and/or plumbing services (customer drawing required)
09	Stainless steel waste flap
15	Finished back on cabinet
16	Ship handles not installed
17	Nylon levelers
18	Horizontally mounted handles
42	One interior cabinet shelf on full extension runners (replaces fixed shelf)
43	Two interior cabinet shelves on full extension runners (replaces fixed shelf)
44	Three interior cabinet shelves on full extension runners (replaces fixed shelf)
45	DuoLite safety glass
46	Tempered glass
47	Customer specified glass
4A	Glass Tint 44% (Grey Smoke)
70	Front toe kick
71	Toe kick - front & left side
72	Toe kick - front & right side
73	Toe kick - front & 2 sides
74	Toe kick - front & back
75	Toe kick - front, back & 2 sides
76	Replace toe kick with 4 legs
79	Other customer specified base or toe kick
80	Full height doors
DC2	Magnetic Door Catch
F2	Finished top and bottom
NB	No base, on cabinet to sit on floor, levelers included
NC	No base, on cabinet to sit on 4" high curb, levelers not included
NF	No cabinet floor and toe kick is integral with door
OLD	Actual depth
PDC	Positive door catch
T1	Replace one shelf with one pull out tray on full extension runners with 2" high lip
T2	Replace two shelves with two pull out trays on full extension runners with 2" high lip
T3	Replace three shelves with three pull out trays on full extension runners with 2" high lip

ACID STORAGE CABINETS

34-3/4" HIGH X 18"/22" DEEP

See page L10 for vent hole locations.

Acid Storage Units (18" Deep)



up to 24" wide



30" and wider

Width	Right Hinged	Left Hinged	# of Doors
15"	1931011W	1931211W	1
18"	1131011W	1131211W	1
24"	1231011W	1231211W	1
30"	1331011W	-	2
36"	1431011W	-	2
42"	1831011W	-	2
48"	1531011W	-	2
513mm	1631011W	1631211W	1
1000mm	1731011W	-	2

- Molded liner and shelf are chemically resistant.
- Add option code VK to order a Corrugated Polyolefin Vent Kit for these units.
- Add option code 82 to change liner to a FRP liner.



up to 24" wide



30" and wider

Width	Right Hinged	Left Hinged	# of Doors
15"	1936022W	1936222W	1
18"	1136022W	1136222W	1
24"	1236022W	1236222W	1
30"	1336022W	-	2
36"	1436022W	-	2
42"	1836022W	-	2
48"	1536022W	-	2
513mm	1636022W	1636222W	1
1000mm	1736022W	-	2

- Molded liner and shelf are chemically resistant.
- False panels are 7-1/2" high.
- Add option code VK to order a Corrugated Polyolefin Vent Kit for these units.
- Add option code 82 to change liner to a FRP liner.

Acid Storage Units (22" Deep)



up to 24" wide



30" and wider

Width	Right Hinged	Left Hinged	# of Doors
15"	1911011W	1911211W	1
18"	1111011W	1111211W	1
24"	1211011W	1211211W	1
30"	1311011W	-	2
36"	1411011W	-	2
42"	1811011W	-	2
48"	1511011W	-	2
513mm	1611011W	1611211W	1
1000mm	1711011W	-	2

- Molded liner and shelf are chemically resistant.
- Add option code VK to order a Corrugated Polyolefin Vent Kit for these units.
- Add option code 82 to change liner to a FRP liner.



up to 24" wide



30" and wider

Width	Right Hinged	Left Hinged	# of Doors
15"	1916022W	1916222W	1
18"	1116022W	1116222W	1
24"	1216022W	1216222W	1
30"	1316022W	-	2
36"	1416022W	-	2
42"	1816022W	-	2
48"	1516022W	-	2
513mm	1616022W	1616222W	1
1000mm	1716022W	-	2

- Molded liner and shelf are chemically resistant.
- False panels are 7-1/2" high.
- Add option code VK to order a Corrugated Polyolefin Vent Kit for these units.
- Add option code 82 to change liner to a FRP liner.

ACID STORAGE CABINETS

28-3/4" HIGH X 18"/22" DEEP

See page L10 for vent hole locations.

Acid Storage Units (18" Deep)



up to 24" wide



30" and wider

Width	Right Hinged	Left Hinged	# of Doors
15"	1941011W	1941211W	1
18"	1141011W	1141211W	1
24"	1241011W	1241211W	1
30"	1341011W	-	2
36"	1441011W	-	2
42"	1841011W	-	2
48"	1541011W	-	2
513mm	1641011W	1641211W	1
1000mm	1741011W	-	2

- Molded liner and shelf are chemically resistant.
- Add option code VK to order a Corrugated Polyolefin Vent Kit for these units.
- Add option code 82 to change liner to a FRP liner.



up to 24" wide



30" and wider

Width	Right Hinged	Left Hinged	# of Doors
15"	1946022W	1946222W	1
18"	1146022W	1146222W	1
24"	1246022W	1246222W	1
30"	1346022W	-	2
36"	1446022W	-	2
42"	1846022W	-	2
48"	1546022W	-	2
513mm	1646022W	1646222W	1
1000mm	1746022W	-	2

- Molded liner and shelf are chemically resistant.
- False panels are 7-1/2" high.
- Add option code VK to order a Corrugated Polyolefin Vent Kit for these units.
- Add option code 82 to change liner to a FRP liner.

Acid Storage Units (22" Deep)



up to 24" wide



30" and wider

Width	Right Hinged	Left Hinged	# of Doors
15"	1921011W	1921211W	1
18"	1121011W	1121211W	1
24"	1221011W	1221211W	1
30"	1321011W	-	2
36"	1421011W	-	2
42"	1821011W	-	2
48"	1521011W	-	2
513mm	1621011W	1621211W	1
1000mm	1721011W	-	2

- Molded liner and shelf are chemically resistant.
- Add option code VK to order a Corrugated Polyolefin Vent Kit for these units.
- Add option code 82 to change liner to a FRP liner.



up to 24" wide



30" and wider

Width	Right Hinged	Left Hinged	# of Doors
15"	1926022W	1926222W	1
18"	1126022W	1126222W	1
24"	1226022W	1226222W	1
30"	1326022W	-	2
36"	1426022W	-	2
42"	1826022W	-	2
48"	1526022W	-	2
513mm	1626022W	1626222W	1
1000mm	1726022W	-	2

- Molded liner and shelf are chemically resistant.
- False panels are 7-1/2" high.
- Add option code VK to order a Corrugated Polyolefin Vent Kit for these units.
- Add option code 82 to change liner to a FRP liner.

ACID STORAGE CABINETS

31-3/4" HIGH X 22" DEEP

See page L10 for vent hole locations.

Acid Storage Units



up to 24" wide



30" and wider

Width	Right Hinged	Left Hinged	# of Doors
15"	1981011W	1981211W	1
18"	1181011W	1181211W	1
24"	1281011W	1281211W	1
30"	1381011W	-	2
36"	1481011W	-	2
42"	1881011W	-	2
48"	1581011W	-	2
513mm	1681011W	1681211W	1
1000mm	1781011W	-	2

- Molded liner and shelf are chemically resistant.
- Add option code VK to order a Corrugated Polyolefin Vent Kit for these units.
- Add option code 82 to change liner to a FRP liner.



up to 24" wide



30" and wider

Width	Right Hinged	Left Hinged	# of Doors
15"	1986022W	1986222W	1
18"	1186022W	1186222W	1
24"	1286022W	1286222W	1
30"	1386022W	-	2
36"	1486022W	-	2
42"	1886022W	-	2
48"	1586022W	-	2
513mm	1686022W	1686222W	1
1000mm	1786022W	-	2

- Molded liner and shelf are chemically resistant.
- False panels are 7-1/2" high.
- Add option code VK to order a Corrugated Polyolefin Vent Kit for these units.
- Add option code 82 to change liner to a FRP liner.

SPECIALTY CABINETS

84" HIGH X 18"/22" DEEP

Acid Storage Units



Width	18" Deep	22" Deep
30"	6322480W	6332480W
36"	6422480W	6432480W
42"	6622480W	6632480W
48"	6522480W	6532480W

- Unit includes four adjustable chemically resistant shelves, one fixed center shelf and a 4" high x 4" diameter stub for exhaust duct connection located 4-3/8" from rear of cabinet.
- This unit comes with Fiber Reinforced Polyester (FRP) lining.
- Add option code 04 to add a standard louver configuration to this unit.

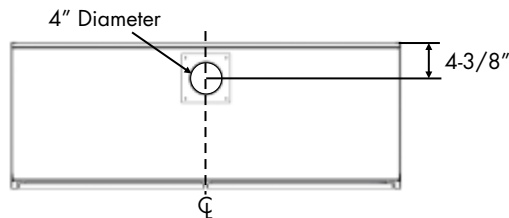

SOLVENT CABINETS

34-3/4" HIGH X 18"/22" DEEP

See page L10 for vent hole locations.

Solvent Units (18" Deep)



up to 24" wide



30" and wider

Width	Right Hinged	Left Hinged	# of Doors
15"	1932011W	1932111W	1
18"	1132011W	1132111W	1
24"	1232011W	1232111W	1
30"	1332011W	-	2
36"	1432011W	-	2
42"	1832011W	-	2
48"	1532011W	-	2
513mm	1632011W	1632111W	1
1000mm	1732011W	-	2

- Add option code 83 to order Self Closing doors. Cabinets over 24" wide will not be UL listed when option code 83 is added.
- Add option code "FL" to order a fusible link on Solvent cabinets with self-closing doors.



up to 24" wide



30" and wider

Width	Right Hinged	Left Hinged	# of Doors
15"	1932022W	1932122W	1
18"	1132022W	1132122W	1
24"	1232022W	1232122W	1
30"	1332022W	-	2
36"	1432022W	-	2
42"	1832022W	-	2
48"	1532022W	-	2
513mm	1632022W	1632122W	1
1000mm	1732022W	-	2

- Add option code 83 to order Self Closing doors. Cabinets over 24" wide will not be UL listed when option code 83 is added.
- Add option code "FL" to order a fusible link on Solvent cabinets with self-closing doors.
- Upper apron assemblies are 6" high. If Variac is required, upper apron increases in height, contact Mott for details.
- Not UL approved with electrical installed. Dimensional modifications may invalidate the UL listing - contact Mott for more information.

Solvent Units (22" Deep)



up to 24" wide



30" and wider

Width	Right Hinged	Left Hinged	# of Doors
15"	1912011W	1912111W	1
18"	1112011W	1112111W	1
24"	1212011W	1212111W	1
30"	1312011W	-	2
36"	1412011W	-	2
42"	1812011W	-	2
48"	1512011W	-	2
513mm	1612011W	1612111W	1
1000mm	1712011W	-	2

- Add option code 83 to order Self Closing doors. Cabinets over 24" wide will not be UL listed when option code 83 is added.
- Add option code "FL" to order a fusible link on Solvent cabinets with self-closing doors.



up to 24" wide



30" and wider

Width	Right Hinged	Left Hinged	# of Doors
15"	1912022W	1912122W	1
18"	1112022W	1112122W	1
24"	1212022W	1212122W	1
30"	1312022W	-	2
36"	1412022W	-	2
42"	1812022W	-	2
48"	1512022W	-	2
513mm	1612022W	1612122W	1
1000mm	1712022W	-	2

- Add option code 83 to order Self Closing doors. Cabinets over 24" wide will not be UL listed when option code 83 is added.
- Add option code "FL" to order a fusible link on Solvent cabinets with self-closing doors.
- Upper apron assemblies are 6" high. If Variac is required, upper apron increases in height, contact Mott for details.
- Not UL approved with electrical installed. Dimensional modifications may invalidate the UL listing - contact Mott for more information.

SOLVENT CABINETS

28-3/4" HIGH X 18"/22" DEEP

See page L10 for vent hole locations.

Solvent Units (18" Deep)



up to 24" wide



30" and wider

Width	Right Hinged	Left Hinged	# of Doors
15"	1942011W	1942111W	1
18"	1142011W	1142111W	1
24"	1242011W	1242111W	1
30"	1342011W	-	2
36"	1442011W	-	2
42"	1842011W	-	2
48"	1542011W	-	2
513mm	1642011W	1642111W	1
1000mm	1742011W	-	2

- Add option code 83 to order Self Closing doors. Cabinets over 24" wide will not be UL listed when option code 83 is added.
- Add option code "FL" to order a fusible link on Solvent cabinets with self-closing doors.

Solvent Units (22" Deep)



up to 24" wide



30" and wider

Width	Right Hinged	Left Hinged	# of Doors
15"	1922011W	1922111W	1
18"	1122011W	1122111W	1
24"	1222011W	1222111W	1
30"	1322011W	-	2
36"	1422011W	-	2
42"	1822011W	-	2
48"	1522011W	-	2
513mm	1622011W	1622111W	1
1000mm	1722011W	-	2

- Add option code 83 to order Self Closing doors. Cabinets over 24" wide will not be UL listed when option code 83 is added.
- Add option code "FL" to order a fusible link on Solvent cabinets with self-closing doors.

SOLVENT CABINETS

31-3/4" HIGH X 22" DEEP

Solvent Units



up to 24" wide



30" and wider

Width	Right Hinged	Left Hinged	# of Doors
15"	1982011W	1982111W	1
18"	1182011W	1182111W	1
24"	1282011W	1282111W	1
30"	1382011W	-	2
36"	1482011W	-	2
42"	1882011W	-	2
48"	1582011W	-	2
513mm	1682011W	1682111W	1
1000mm	1782011W	-	2

- Add option code 83 to order Self Closing doors. Cabinets over 24" wide will not be UL listed when option code 83 is added.
- Add option code "FL" to order a fusible link on Solvent cabinets with self-closing doors.

PUMP STORAGE CABINETS

34-3/4" HIGH X 18"/22" DEEP

See page L10 for vent hole locations.

Pump Storage Cabinets (18" Deep)



up to 24" wide



30" and wider

Width	Right Hinged	Left Hinged	# of Doors
15"	193P011W	193P211W	1
18"	113P011W	113P211W	1
24"	123P011W	123P211W	1
30"	133P011W	-	2
36"	143P011W	-	2
42"	183P011W	-	2
48"	153P011W	-	2
513mm	163P011W	163P211W	1
1000mm	173P011W	-	2

- See "Note 1" on page L8.
- Add option code PF for optional pump storage cabinet fan.



up to 24" wide



30" and wider

Width	Right Hinged	Left Hinged	# of Doors
15"	193P022W	193P222W	1
18"	113P022W	113P222W	1
24"	123P022W	123P222W	1
30"	133P022W	-	2
36"	143P022W	-	2
42"	183P022W	-	2
48"	153P022W	-	2
513mm	163P022W	163P222W	1
1000mm	173P022W	-	2

- See "Note 2" on page L8.
- Add option code PF for optional pump storage cabinet fan.

Pump Storage Cabinets (22" Deep)



up to 24" wide



30" and wider

Width	Right Hinged	Left Hinged	# of Doors
15"	191P011W	191P211W	1
18"	111P011W	111P211W	1
24"	121P011W	121P211W	1
30"	131P011W	-	2
36"	141P011W	-	2
42"	181P011W	-	2
48"	151P011W	-	2
513mm	161P011W	161P211W	1
1000mm	171P011W	-	2

- See "Note 1" on page L8.
- Add option code PF for optional pump storage cabinet fan.



up to 24" wide



30" and wider

Width	Right Hinged	Left Hinged	# of Doors
15"	191P022W	191P222W	1
18"	111P022W	111P222W	1
24"	121P022W	121P222W	1
30"	131P022W	-	2
36"	141P022W	-	2
42"	181P022W	-	2
48"	151P022W	-	2
513mm	161P022W	161P222W	1
1000mm	171P022W	-	2

- See "Note 2" on page L8.
- Add option code PF for optional pump storage cabinet fan.

PUMP STORAGE CABINETS

28-3/4" HIGH X 18"/22" DEEP

See page L10 for vent hole locations.

Pump Storage Cabinets (18" Deep)



up to 24" wide



30" and wider

Width	Right Hinged	Left Hinged	# of Doors
15"	194P011W	194P211W	1
18"	114P011W	114P211W	1
24"	124P011W	124P211W	1
30"	134P011W	-	2
36"	144P011W	-	2
42"	184P011W	-	2
48"	154P011W	-	2
513mm	164P011W	164P211W	1
1000mm	174P011W	-	2

- See "Note 1" on page L8.
- Add option code PF for optional pump storage cabinet fan.



up to 24" wide



30" and wider

Width	Right Hinged	Left Hinged	# of Doors
15"	194P022W	194P222W	1
18"	114P022W	114P222W	1
24"	124P022W	124P222W	1
30"	134P022W	-	2
36"	144P022W	-	2
42"	184P022W	-	2
48"	154P022W	-	2
513mm	164P022W	164P222W	1
1000mm	174P022W	-	2

- See "Note 2" on page L8.
- Add option code PF for optional pump storage cabinet fan.

Pump Storage Cabinets (22" Deep)



up to 24" wide



30" and wider

Width	Right Hinged	Left Hinged	# of Doors
15"	192P011W	192P211W	1
18"	112P011W	112P211W	1
24"	122P011W	122P211W	1
30"	132P011W	-	2
36"	142P011W	-	2
42"	182P011W	-	2
48"	152P011W	-	2
513mm	162P011W	162P211W	1
1000mm	172P011W	-	2

- See "Note 1" on page L8.
- Add option code PF for optional pump storage cabinet fan.



up to 24" wide



30" and wider

Width	Right Hinged	Left Hinged	# of Doors
15"	192P022W	192P222W	1
18"	112P022W	112P222W	1
24"	122P022W	122P222W	1
30"	132P022W	-	2
36"	142P022W	-	2
42"	182P022W	-	2
48"	152P022W	-	2
513mm	162P022W	162P222W	1
1000mm	172P022W	-	2

- See "Note 2" on page L8.
- Add option code PF for optional pump storage cabinet fan.

PUMP STORAGE CABINETS

31-3/4" HIGH X 22" DEEP

See page L10 for vent hole locations.

Pump Storage Cabinets



up to 24" wide



30" and wider

Width	Right Hinged	Left Hinged	# of Doors
15"	198P011W	198P211W	1
18"	118P011W	118P211W	1
24"	128P011W	128P211W	1
30"	138P011W	-	2
36"	148P011W	-	2
42"	188P011W	-	2
48"	158P011W	-	2
513mm	168P011W	168P211W	1
1000mm	178P011W	-	2

Note 1:

- Pump Storage Cabinets with full doors are insulated with sound absorption foam for noise reduction.
- Vent hose connection and 120V/20 amp (15 amp in Canada) duplex receptacle is located on the rear of the cabinet and includes 8 feet of electrical whip.
- Cabinets come complete with a pull-out shelf and removable access panel at the back of the cabinet.
- Add option code PF for optional pump cabinet fan.
- Vibration isolators are available, contact Mott Manufacturing for details.
- Fan information: 115 VAC, 120 X 120 X 38mm, 81 CFM



up to 24" wide



30" and wider

Width	Right Hinged	Left Hinged	# of Doors
15"	198P022W	198P222W	1
18"	118P022W	118P222W	1
24"	128P022W	128P222W	1
30"	138P022W	-	2
36"	148P022W	-	2
42"	188P022W	-	2
48"	158P022W	-	2
513mm	168P022W	168P222W	1
1000mm	178P022W	-	2

Note 2:

- Pump Storage Cabinets with a false panel are insulated with sound absorption foam for noise reduction.
- Vent hose connection is located on the rear of these cabinets.
- These cabinets are supplied with switch and outlet pre-wired to junction box on back panel and includes 8 feet of electrical whip.
- False panels on these cabinets are 7-1/2" high.
- Switch shown on the false panel controls interior 120V/20amp (15 amp in Canada) duplex receptacle for remote ON/OFF control.
- Cabinets come complete with a pull-out shelf and removable access panel at the back of the cabinet.
- Add option code PF for optional pump cabinet fan.
- Vibration isolators are available, contact Mott Manufacturing for details.
- Fan information: 115 VAC, 120 X 120 X 38mm, 81 CFM

CONTROL PANEL CABINETS

34-3/4" HIGH X 22" DEEP

Control Panel Units



up to 24" wide



30" and wider

Width	Right Hinged	Left Hinged	# of Doors
12"	1015022W	1015222W	1
15"	1915022W	1915222W	1
18"	1115022W	1115222W	1
24"	1215022W	1215222W	1
30"	1315022W	-	2
36"	1415022W	-	2
42"	1815022W	-	2
48"	1515022W	-	2
513mm	1615022W	1615222W	1
1000mm	1715022W	-	2

CONTROL PANEL CABINETS

28-3/4" HIGH X 22" DEEP

Control Panel Units



up to 24" wide



30" and wider

Width	Right Hinged	Left Hinged	# of Doors
12"	1025022W	1025222W	1
15"	1925022W	1925222W	1
18"	1125022W	1125222W	1
24"	1225022W	1225222W	1
30"	1325022W	-	2
36"	1425022W	-	2
42"	1825022W	-	2
48"	1525022W	-	2
513mm	1625022W	1625222W	1
1000mm	1725022W	-	2

CONTROL PANEL CABINETS

31-3/4" HIGH X 22" DEEP

Control Panel Units



up to 24" wide



30" and wider

Width	Right Hinged	Left Hinged	# of Doors
12"	1085022W	1085222W	1
15"	1985022W	1985222W	1
18"	1185022W	1185222W	1
24"	1285022W	1285222W	1
30"	1385022W	-	2
36"	1485022W	-	2
42"	1885022W	-	2
48"	1585022W	-	2
513mm	1685022W	1685222W	1
1000mm	1785022W	-	2

ACID/SOLVENT/PUMP CABINETS

CONSTRUCTION DETAILS

Acid Cabinet Details

Molded polyethylene liner (molded liners are removable) and shelf are chemically resistant on Acid cabinets. Removable liner is held in place with capped stainless steel screws and has a vent connection. 3/16" thick fiberglass reinforced polyester liner is provided on tall Acid cabinets and an available option on base cabinets. Cabinets are marked "ACID" - in red letters.

Note: Acid Cabinets must be vented. Mott recommends venting acid cabinets with a Polyolefin Vent Kit (PVSS for Molded Tub liner cabinets or PVSA for FRP liner cabinets - see fume hood section). Vent location applies to 28-3/4", 31-3/4" and 34-3/4" height cabinets.

Cabinet Vent Hole Location

Vent hole location for all Acid Cabinets.

2"Dia Female National Pipe Thread vent connection on cabinets with Molded Tub Liners and 1-1/2" Plain Hole on cabinets with FRP Liners.

Acid Cabinet Rear View

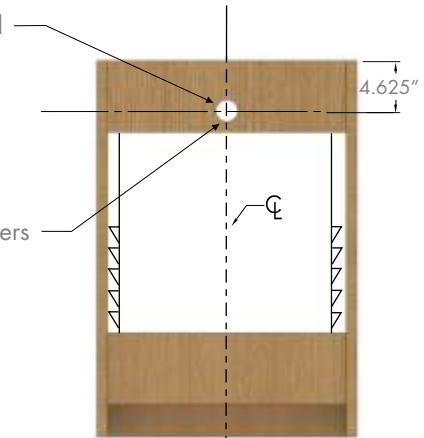

Solvent Cabinet Details

Solvent Storage cabinets are approved to UL1275, and meet National Fire Protection Association standards. The floor of the cabinet has a 2" deep liquid tight spill containment pan. Doors are mounted on continuous hinges with a three point locking self latching handle. Each cabinet has two 2" diameter vents in the rear of the cabinet, complete with flame arrestor and vent covers. Each cabinet has one chemically resistant shelf. Optional self closing doors and self closing/latching doors with a fusible link are also available. Cabinets are marked "FLAMMABLE KEEP FIRE AWAY" - in red letters.

Note: NFPA30 does not require Solvent cabinets to be vented. Do not vent Solvent Cabinets to fume hood. If cabinet must be vented use fireproof pipe. Contact Mott for details. Vent location applies to 28-3/4", 31-3/4", 34-3/4" height cabinets.

Solvent Cabinet Rear View

2"Dia Female National Pipe Thread in two places as shown

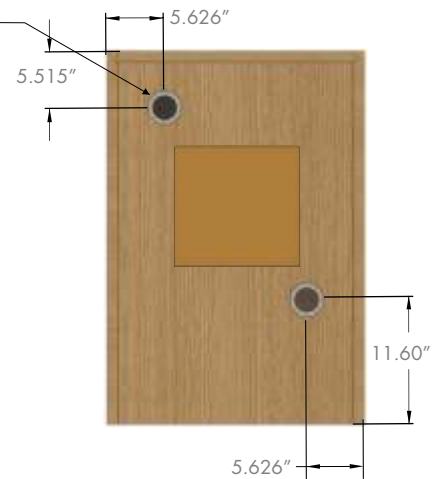

Pump Storage Cabinet Details

Pump cabinets are insulated with 1" thick acoustic foam which provides sound absorption and noise reduction over a wide range of frequencies. Foam is attached to the interior of the cabinet including the door by an adhesive backing on the foam. The foam is fire resistant and complies with MVSS 302 AND UL94 HF-1 requirements. Two vent holes are incorporated in the cabinet back for connections to centralized lab exhaust systems. Custom vent cutouts are available. Back access panel is easily removable to provide convenient access to venting or electrical connections after installation. One 120 Volt / 20 Amp (15 Amp in Canada) electrical duplex receptacle provides power to the vacuum pump (final power connection required). The switch that controls receptacles is located on the front panel on False Panel Units; Full height Door Units are typically wired through the fume hood.

Pump Storage Cabinet Rear View

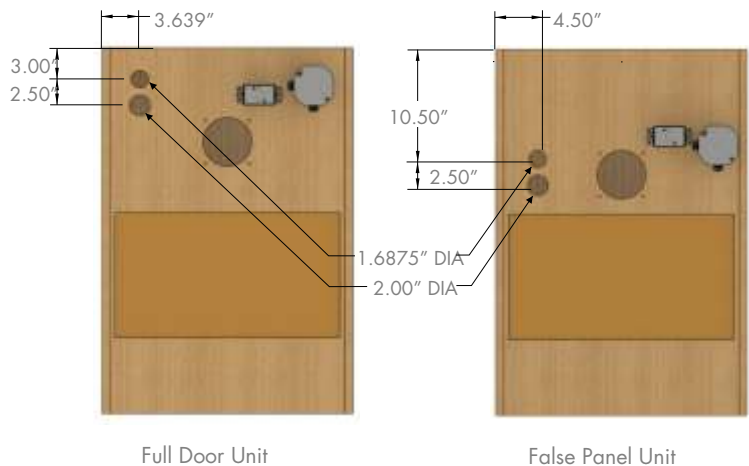

All dimensions and sizes shown are nominal. Specifications and details are based on product information at the time of printing and may change at any time without notice. Mott Manufacturing reserves the right to change dimensions, specifications and manufacturing details at any time without notice.

SPECIALTY CABINET OPTIONS

Option Code	Description
00	Modified door/drawer configuration
02	Label holders on all doors/drawers
03	Numeric or alpha identification disks on all doors/drawers (customer details required)
04	Standard louver configuration on doors (6 louvers at 3" wide x 5-1/2" long)
05	Non-standard louver configuration on doors (customer drawing required)
07	Cut-outs for electrical and/or plumbing services (customer drawing required)
14	Ventilation grill in toe kick base
15	Finished back on cabinet
16	Ship handles not installed
17	Nylon levelers
18	Horizontally mounted handles
40	One extra cabinet shelf
41	Two extra cabinet shelves
42	One interior cabinet shelf on full extension runners (replaces fixed shelf)
43	Two interior cabinet shelves on full extension runners (replaces fixed shelf)
44	Three interior cabinet shelves on full extension runners (replaces fixed shelf)
70	Front toe kick
71	Toe kick - front & left side
72	Toe kick - front & right side
73	Toe kick - front & 2 sides
74	Toe kick - front & back
75	Toe kick - front, back & 2 sides
76	Replace toe kick with 4 legs
77	Replace toe kick with 4 casters
78	Replace toe kick with customer specified casters
79	Other customer specified base or toe kick
82	FRP liner for acid cabinets
83	Self closing and latching doors for solvent cabinet
CL	Corrosive label
C25	Replace toe kick with casters, 250lbs each
F2	Finished top and back
FL	Fusible link with self closer for insulated solvent unit *
LA	Bilingual label (French/English)
NB	No base, cabinet to sit on floor, levelers included
NC	No base, cabinet to sit on 4" high curb, levelers not included
NF	No cabinet floor and toe kick is integral with door
NFD	Pump cabinet unit with no cabinet floor and toe kick is integral with door, dolly included
OLD	Actual depth
PF	Pump cabinet fan
PC	Foot pedal cutouts centered
PL	Foot pedal cutout left hand side
PR	Foot pedal cutout right hand side
PP	Pre-plumbed (option code not for fume hoods) (customer details required)
PW	Pre-wired (option code not for fume hoods) (customer details required)
SK	Skid item
SP	Silk screen printing (to replace standard labels on acid and/or flammable cabinets)
T1	Replace one shelf with one pull out tray on full extension runners with 2" high lip
VK	Corrugated polyolefin vent kit for acid cabinets
VS	Vent holes on side of cabinet

Note: *Designed for use on solvent cabinets with self-closing and latching doors (option code 83).
A fusible link holds doors open during use and melts at 165° F to automatically close doors in the event of a fire.

SUSPENDED CABINETS

24" HIGH X 22" DEEP

Open Units



Width	Item Number
15"	195000W
18"	115000W
24"	125000W
30"	135000W
36"	145000W
42"	185000W
48"	155000W
513mm	165000W
1000mm	175000W

- Actual depths 7/8" less than nominal.

Full Door Units



up to 24" wide



30" and wider

Width	Right Hinged	Left Hinged	# of Doors
15"	1950011W	1950211W	1
18"	1150011W	1150211W	1
24"	1250011W	1250211W	1
30"	1350011W	-	2
36"	1450011W	-	2
42"	1850011W	-	2
48"	1550011W	-	2
513mm	1650011W	1650211W	1
1000mm	1750011W	-	2

- Cabinets receive one shelf.

Door/Drawer Units



up to 24" wide



30" and wider

Width	Right Hinged	Left Hinged	# of Doors
15"	1950022W	1950222W	1
18"	1150022W	1150222W	1
24"	1250022W	1250222W	1
30"	1350022W	-	2
36"	1450022W	-	2
42"	1850022W	-	2
48"	1550022W	-	2
513mm	1650022W	1650222W	1
1000mm	1750022W	-	2

- Cabinets up to 24" wide receive one shelf.
- Cabinets 25" and wider do not have a shelf.



Width	Right Hand	Left Hand
30"	1350041W	1350014W
36"	1450041W	1450014W
42"	1850041W	1850014W
48"	1550041W	1550014W
1000mm	1750041W	1750014 W

- Left hand Door/Drawer Unit shown.
- Right hand Door/Drawer Units are reverse of what is shown.
- Cabinets receive one shelf.

Sliding Door Units



Width	Item Number
30"	1350711W
36"	1450711W
42"	1850711W
48"	1550711W
1000mm	1750711W

- Actual depths 7/8" less than nominal.
- Cabinets receive one shelf.

SUSPENDED CABINETS

24" HIGH X 22" DEEP

Drawer Units



up to 24" wide



30" and wider

Width	Item Number
15"	1950044W
18"	1150044W
24"	1250044W
30"	1350044W
36"	1450044W
42"	1850044W
48"	1550044W
513mm	1650044W
1000mm	1750044W



up to 24" wide



30" and wider

Width	Item Number
15"	1950055W
18"	1150055W
24"	1250055W
30"	1350055W
36"	1450055W
42"	1850055W
48"	1550055W
513mm	1650055W
1000mm	1750055W



up to 24" wide



30" and wider

Width	Item Number
15"	1950066W
18"	1150066W
24"	1250066W
30"	1350066W
36"	1450066W
42"	1850066W
48"	1550066W
513mm	1650066W
1000mm	1750066W



Width	Item Number
30"	1350097W
36"	1450097W
42"	1850097W
48"	1550097W
1000mm	1750097W



Width	Item Number
30"	1350098W
36"	1450098W
42"	1850098W
48"	1550098W
1000mm	1750098W

SUSPENDED CABINETS

24" HIGH X 22" DEEP

File Drawer Units



up to 24" wide



30" and wider



up to 24" wide



30" and wider



up to 24" wide



30" and wider

Width	Item Number
15"	1950122W
18"	1150122W
24"	1250122W
30"	1350122W
36"	1450122W
42"	1850122W
48"	1550122W
513mm	1650122W
1000mm	1750122W

Width	Item Number
15"	1950177W
18"	1150177W
24"	1250177W
30"	1350177W
36"	1450177W
42"	1850177W
48"	1550177W
513mm	1650177W
1000mm	1750177W

Width	Item Number
15"	1950188W
18"	1150188W
24"	1250188W
30"	1350188W
36"	1450188W
42"	1850188W
48"	1550188W
513mm	1650188W
1000mm	1750188W

Sink Units



up to 24" wide



30" and wider

Width	Right Hinged	Left Hinged	# of Doors
15"	1953011W	1953211W	1
18"	1153011W	1153211W	1
24"	1253011W	1253211W	1
30"	1353011W	-	2
36"	1453011W	-	2
42"	1853011W	-	2
48"	1553011W	-	2
513mm	1653011W	1653211W	1
1000mm	1753011W	-	2

• Add option code 90 to order Sink Hanger Supports.

Acid Storage Units



up to 24" wide



30" and wider

Width	Right Hinged	Left Hinged	# of Doors
15"	1951011W	1951211W	1
18"	1151011W	1151211W	1
24"	1251011W	1251211W	1
30"	1351011W	-	2
36"	1451011W	-	2
42"	1851011W	-	2
48"	1551011W	-	2
513mm	1651011W	1651211W	1
1000mm	1751011W	-	2

- Cabinet receives a molded liner and one chemically resistant shelf.
- Add option code VK to order a Corrugated Polyolefin Vent Kit for these units.
- Note: Acid Cabinets must be vented. Mott recommends venting acid cabinets with a Polyolefin Vent Kit (PVSA for FRP lined cabinets).

SUSPENDED CABINETS

24" HIGH X 22" DEEP

Solvent Storage Units



up to 24" wide



30" and wider

Width	Right Hinged	Left Hinged	# of Doors
15"	1952011W	1952211W	1
18"	1152011W	1152211W	1
24"	1252011W	1252211W	1
30"	1352011W	-	2
36"	1452011W	-	2
42"	1852011W	-	2
48"	1552011W	-	2
513mm	1652011W	1652211W	1
1000mm	1752011W	-	2

- Solvent Units are designed to meet OSHA and NFPA 30 standards.
- Add option code 83 to order Self Closing/Latching doors.
- Add option code "FL" to order Self Closing/latching doors with a fusible link.
- See page L10 for Solvent cabinet details.

SUSPENDED CABINETS

18" HIGH X 22" DEEP

Open Units



Width	Item Number
15"	1960000W
18"	1160000W
24"	1260000W
30"	1360000W
36"	1460000W
42"	1860000W
48"	1560000W
513mm	1660000W
1000mm	1760000W

- Actual depths 7/8" less than nominal.

Full Door Unit



up to 24" wide



30" and wider

Width	Right Hinged	Left Hinged	# of Doors
15"	1960011W	1960211W	1
18"	1160011W	1160211W	1
24"	1260011W	1260211W	1
30"	1360011W	-	2
36"	1460011W	-	2
42"	1860011W	-	2
48"	1560011W	-	2
513mm	1660011W	1660211W	1
1000mm	1760011W	-	2

Door/Drawer Units



up to 24" wide



30" and wider

Width	Right Hinged	Left Hinged	# of Doors
15"	1960022W	1960222W	1
18"	1160022W	1160222W	1
24"	1260022W	1260222W	1
30"	1360022W	-	2
36"	1460022W	-	2
42"	1860022W	-	2
48"	1560022W	-	2
513mm	1660022W	1660222W	1
1000mm	1760022W	-	2



Width	Right Hinged	Left Hinged
30"	1360041W	1360014W
36"	1460041W	1460014W
42"	1860041W	1860014W
48"	1560041W	1560014W
1000mm	1760041W	1760014W

- Right hand Door/Drawer Unit shown. Left hand reversed.

SUSPENDED CABINETS

18" HIGH X 22" DEEP

Drawer Units



up to 24" wide



30" and wider

Width	Item Number
15"	1960044W
18"	1160044W
24"	1260044W
30"	1360044W
36"	1460044W
42"	1860044W
48"	1560044W
513mm	1660044W
1000mm	1760044W

File Drawer Units



up to 24" wide



30" and wider

Width	Item Number
15"	1960177W
18"	1160177W
24"	1260177W
30"	1360177W
36"	1460177W
42"	1860177W
48"	1560177W
513mm	1660177W
1000mm	1760177W

Sink Units



up to 24" wide



30" and wider

Width	Right Hinged	Left Hinged	# of Doors
15"	1963011W	1963211W	1
18"	1163011W	1163211W	1
24"	1263011W	1263211W	1
30"	1363011W	-	2
36"	1463011W	-	2
42"	1863011W	-	2
48"	1563011W	-	2
513mm	1663011W	1663211W	1
1000mm	1763011W	-	2

- Add option code 90 to order Sink Hanger Supports.

Hanging Rails



Width	Item Number
15"	HR00015
18"	HR00018
24"	HR00024
30"	HR00030
36"	HR00036
42"	HR00042
48"	HR00048
513mm	HR00020
1000mm	HR00040

- Pair of hanging rails only suitable for wood suspended cabinets.

SUSPENDED CABINET OPTIONS

Option Code	Description
00	Modified door/drawer configuration
02	Label holders on all doors/drawers
03	Numeric or alpha identification disks on all doors/drawers (customer details required)
04	Standard louver configuration on doors (6 louvers at 3" wide x 5-1/2" long)
05	Non-standard louver configuration on doors (customer drawing required)
07	Cut-outs for electrical and/or plumbing services (customer drawing required)
08	Security proof panel
09	Stainless steel waste flap
10	One fixed drawer divider per drawer (centered in drawer)
11	Multiple drawer dividers per drawer (customer drawing required)
12	Pull out writing board - all cold rolled steel*
13	Pull out writing board - high pressure laminate writing surface*
15	Finished back on cabinet
16	Ship handles not installed
18	Horizontally mounted handles
26	200 lbs full extension drawer runners
40	One extra cabinet shelf
41	Two extra cabinet shelves
42	One interior cabinet shelf on full extension runners (replaces fixed shelf)
43	Two interior cabinet shelves on full extension runners (replaces fixed shelf)
44	Three interior cabinet shelves on full extension runners (replaces fixed shelf)
48	Keyboard tray (replace drawer)
82	FRP liner for acid cabinets
83	Self closing and latching doors for solvent cabinet
90	Sink supports - for under counter mounted sinks
BL	"Base" label (use this option code to replace standard label on acid cabinets)
CL	Corrosive label
DC2	Magnetic Door Catch
F2	Finished top and back
FL	Fusible link with self closer for insulated unit**
LA	Bilingual label (French/English)
LF	Longitudinal file
OLD	Actual depth
PP	Pre-plumbed (option code not to be used for fume hoods)(customer details required)
PW	Pre-wired (option code not to be used for fume hoods) (customer details required)
PDC	Positive door catch
PFE	Pull out writing board on full extension runners*
RB	Removable back on drawer cabinet
SK	Skid item
SP	Silk screen printing (to replace standard labels on acid and/or flammable cabinets)
VK	Corrugated polyolefin vent kit for acid cabinets
VS	Vent holes on side of cabinet
T1	Replace one shelf with one pull out tray on full extension runners with 2" high lip
T2	Replace two shelves with two pull out trays on full extension runners with 2" high lip
T3	Replace three shelves with three pull out trays on full extension runners with 2" high lip

Notes: *30" wide cabinets and above receive 2 pull out writing boards unless it's a full width drawer cabinet.

Note: **Designed for use on solvent cabinets with self-closing and latching doors (option code 83). A fusible link holds doors open during use and melts at 165° F to automatically close doors in the event of a fire.

MISCELLANEOUS ITEMS

Front Filler Panels



- The Front Filler Panel is used to close a space between two base cabinets.
- Filler panels can be ordered in 1" increments, up to 24" wide. Change the last two digits to the dimension required.

Width	Standing Ht.	Sitting Ht.	ADA Ht.	84" High
1"	FFC1001W	FFC2001W	FFC8001W	FFC3001W
2"	FFC1002W	FFC2002W	FFC8002W	FFC3002W
4"	FFC1004W	FFC2004W	FFC8004W	FFC3004W
6"	FFC1006W	FFC2006W	FFC8006W	FFC3006W
8"	FFC1008W	FFC2008W	FFC8008W	FFC3008W
10"	FFC1010W	FFC2010W	FFC8010W	FFC3010W
12"	FFC1012W	FFC2012W	FFC8012W	FFC3012W
24"	FFC1024W	FFC2024W	FFC8024W	FFC3024W

Corner Filler Panels



- The Corner Filler Panel is used to close a corner space between two base cabinets.

Width & Depth	Standing Ht.	Sitting Ht.	ADA Ht.
1" x 1"	CFC1001W	CFC2001W	CFC8001W
2" x 2"	CFC1002W	CFC2002W	CFC8002W
4" x 4"	CFC1004W	CFC2004W	CFC8004W
6" x 6"	CFC1006W	CFC2006W	CFC8006W

End Cover Panels



- End Cover Channels are fixed width and are used to close spaces between the back of a base cabinet and a wall.
- Filler panels can be ordered in 1" increments, up to 24" wide. Change the last two digits to the dimension required.

Width	Standing Ht.	Sitting Ht.	ADA Ht.	84" High
1"	ECC1001W	ECC2001W	ECC5001W	ECC3001W
2"	ECC1002W	ECC2002W	ECC5002W	ECC3002W
4"	ECC1004W	ECC2004W	ECC5004W	ECC3004W
7"	ECC1007W	ECC2007W	ECC5007W	ECC3007W
13"	ECC1013W	ECC2013W	ECC5013W	ECC3013W
14"	ECC1014W	ECC2014W	ECC5014W	ECC3014W
120mm	ECC100AW	ECC200AW	ECC500AW	ECC300AW

MISCELLANEOUS ITEMS

Front Wall Filler - 14" Deep



- The Wall Filler is used to close a space between two wall cabinets.
- Filler panels can be ordered in 1" increments, up to 24" wide. Change the last two digits to the dimension required.
- Depth dimensions are nominal.

Width	24" High	30" High	36" High	48" High
1"	WFP5301W	WFP6301W	WFP7301W	WFP8301W
2"	WFP5302W	WFP6302W	WFP7302W	WFP8302W
3"	WFP5303W	WFP6303W	WFP7303W	WFP8303W
4"	WFP5304W	WFP6304W	WFP7304W	WFP8304W
6"	WFP5306W	WFP6306W	WFP7306W	WFP8306W
8"	WFP5308W	WFP6308W	WFP7308W	WFP8308W
10"	WFP5310W	WFP6310W	WFP7310W	WFP8310W
12"	WFP5312W	WFP6312W	WFP7312W	WFP8312W
15"	WFP5315W	WFP6315W	WFP7315W	WFP8315W
18"	WFP5318W	WFP6318W	WFP7318W	WFP8318W
24"	WFP5324W	WFP6324W	WFP7324W	WFP8324W

Front Wall Fillers - 18" Deep



- The Wall Filler is used to close a space between two wall cabinets.
- Filler panels can be ordered in 1" increments, up to 24" wide. Change the last two digits to the dimension required.
- Depth dimensions are nominal.

Width	24" High	30" High	36" High	48" High
1"	WFP5201W	WFP6201W	WFP7201W	WFP8201W
2"	WFP5202W	WFP6202W	WFP7202W	WFP8202W
3"	WFP5203W	WFP6203W	WFP7203W	WFP8203W
4"	WFP5204W	WFP6204W	WFP7204W	WFP8204W
6"	WFP5206W	WFP6206W	WFP7206W	WFP8206W
8"	WFP5208W	WFP6208W	WFP7208W	WFP8208W
10"	WFP5210W	WFP6210W	WFP7210W	WFP8210W
12"	WFP5212W	WFP6212W	WFP7212W	WFP8212W
15"	WFP5215W	WFP6215W	WFP7215W	WFP8215W
18"	WFP5218W	WFP6218W	WFP7218W	WFP8218W
24"	WFP5224W	WFP6224W	WFP7224W	WFP8224W

Light Valances

- Light valances are to be fastened to the bottom of a wall cabinet. Available with left side, right side, or both returns.
- Light valances are 3" high with horizontal wood grain.

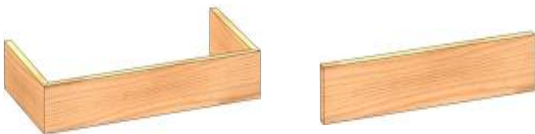

- Light valance returns are 7/8" shorter in depth than the standard depth of the cabinet.
- Front Only Light Valance to be fastened to the bottom of a wall cabinet.

Width	Right & Left Side Return		Front Only
	14" Return	18" Return	
18"	VPS3018W	VPS4018W	VPF1018W
24"	VPS3024W	VPS4024W	VPF1024W
30"	VPS3030W	VPS4030W	VPF1030W
36"	VPS3036W	VPS4036W	VPF1036W
42"	VPS3042W	VPS4042W	VPF1042W
48"	VPS3048W	VPS4048W	VPF1048W
60"	VPS3060W	VPS4060W	VPF1060W
72"	VPS3072W	VPS4072W	VPF1072W
96"	VPS3096W	VPS4096W	VPF1096W



- Left hand return Light Valance shown.
- Right hand return Light Valances are reverse of what is shown.

Width	Right Side Return		Left Side Return	
	14" Return	18" Return	14" Return	18" Return
18"	VPR3018W	VPR4018W	VPL3018W	VPL4018W
24"	VPR3024W	VPR4024W	VPL3024W	VPL4024W
30"	VPR3030W	VPR4030W	VPL3030W	VPL4030W
36"	VPR3036W	VPR4036W	VPL3036W	VPL4036W
42"	VPR3042W	VPR4042W	VPL3042W	VPL4042W
48"	VPR3048W	VPR4048W	VPL3048W	VPL4048W
60"	VPR3060W	VPR4060W	VPL3060W	VPL4060W
72"	VPR3072W	VPR4072W	VPL3072W	VPL4072W
96"	VPR3096W	VPR4096W	VPL3096W	VPL4096W

MISCELLANEOUS ITEMS

Front Rails



- Front Rails are commonly used to finish a space at a sitting area when a full frame apron is not required.
- Sides are not edge banded.

Width	2" High	3-3/4" High
15"	FRB0015W	FRA0015W
18"	FRB0018W	FRA0018W
24"	FRB0024W	FRA0024W
30"	FRB0030W	FRA0030W
36"	FRB0036W	FRA0036W
42"	FRB0042W	FRA0042W
48"	FRB0048W	FRA0048W
54"	FRB0054W	FRA0054W
60"	FRB0060W	FRA0060W
66"	FRB0066W	FRA0066W
72"	FRB0072W	FRA0072W
513mm	FRB000AW	FRA000AW
1000mm	FRB000BW	FRA000BW

Front Rail Service Covers



Width	Standing Height	Sitting Height	ADA Height
15"	SCP1015W	SCP2015W	SCP5015W
18"	SCP1018W	SCP2018W	SCP5018W
24"	SCP1024W	SCP2024W	SCP5024W
30"	SCP1030W	SCP2030W	SCP5030W
36"	SCP1036W	SCP2036W	SCP5036W
42"	SCP1042W	SCP2042W	SCP5042W
48"	SCP1048W	SCP2048W	SCP5048W
54"	SCP1054W	SCP2054W	SCP5054W
60"	SCP1060W	SCP2060W	SCP5060W
66"	SCP1066W	SCP2066W	SCP5066W
513mm	SCP100AW	SCP2100AW	SCP500AW
1000mm	SCP100BW	SCP200BW	SCP500BW

- Front Rail Service Cover panels are used to conceal open spaces and services where front rails are in place
- Attaches to adjacent cabinets and meets the underside of the work surface.
- Assembly includes single angles for attachment to adjacent cabinets. Upper panel is removable to allow access to the services. The lower panel stays fixed in order to apply covered base.

Apron Service Covers



Width	Standing Height	Sitting Height	ADA Height
15"	SCP3015W	SCP4015W	SCP6015W
18"	SCP3018W	SCP4018W	SCP6018W
24"	SCP3024W	SCP4024W	SCP6024W
30"	SCP3030W	SCP4030W	SCP6030W
36"	SCP3036W	SCP4036W	SCP6036W
42"	SCP3042W	SCP4042W	SCP6042W
48"	SCP3048W	SCP4048W	SCP6048W
54"	SCP3054W	SCP4054W	SCP6054W
60"	SCP3060W	SCP4060W	SCP6060W
66"	SCP3066W	SCP4066W	SCP6066W
513mm	SCP300AW	SCP400AW	SCP600AW
1000mm	SCP300BW	SCP400BW	SCP600BW

- Apron Service Cover panels are used to conceal open spaces and services below aprons.
- Attaches to adjacent cabinets and meets the underside of the bottom of the apron.
- Assembly includes single angles for attachment to adjacent cabinets. Upper panel is removable to allow access to the services. The lower panel stays fixed in order to apply covered base.

MISCELLANEOUS ITEMS

Apron Units - 22" Deep



Width	Plain Front	With Drawers	With Book Compartments	# of Drawers	# of Compartments
24"	AUC0124W	AUA0124W	AUB0124W	1	1
30"	AUC0130W	AUA0130W	AUB0130W	1	2
36"	AUC0136W	AUA0136W	AUB0136W	1	2
42"	AUC0142W	AUA0142W	AUB0142W	1	2
48"	AUC0148W	AUA0148W	AUB0148W	2	3
54"	AUC0154W	AUA0154W	AUB0154W	2	3
60"	AUC0160W	AUA0160W	AUB0160W	2	4
66"	AUC0166W	AUA0166W	AUB0166W	2	4
72"	AUC0172W	AUA0172W	AUB0172W	2	4
513mm	AUC010AW	AUA010AW	AUB010AW	1	1
1000mm	AUC010BW	AUA010BW	AUB010BW	1	2

- Aprons provide a work area from a seated position.
- Aprons are available plain or with drawers or with book compartments.
- Aprons are 3-3/4" high.
- Book compartments have an interior depth of 16".
- Actual depth 7/8" less than nominal.

Apron Units 28" Deep



Width	Plain Front	With Drawers	With Book Compartments	# of Drawers	# of Compartments
24"	AUC0424W	AUA0424W	AUB0424W	1	1
30"	AUC0430W	AUA0430W	AUB0430W	1	2
36"	AUC0436W	AUA0436W	AUB0436W	1	2
42"	AUC0442W	AUA0442W	AUB0442W	1	2
48"	AUC0448W	AUA0448W	AUB0448W	2	3
54"	AUC0454W	AUA0454W	AUB0454W	2	3
60"	AUC0460W	AUA0460W	AUB0460W	2	4
66"	AUC0466W	AUA0466W	AUB0466W	2	4
72"	AUC0472W	AUA0472W	AUB0472W	2	4
513mm	AUC040AW	AUA040AW	AUB040AW	1	1
1000mm	AUC040BW	AUA040BW	AUB040BW	1	2

- Aprons provide a work area from a seated position.
- Aprons are available plain, or with drawers or with book compartments.
- Aprons are 3-3/4" high.
- Book compartments have an interior depth of 16".
- Actual depth 7/8" less than nominal.

Arched Rail Apron Units



Width	22" Deep	28" Deep
24"	AUC0224W	AUC0324W
30"	AUC0230W	AUC0330W
36"	AUC0236W	AUC0336W
42"	AUC0242W	AUC0342W
48"	AUC0248W	AUC0348W
54"	AUC0254W	AUC0354W
60"	AUC0260W	AUC0360W
66"	AUC0266W	AUC0366W
72"	AUC0272W	AUC0372W
513mm	AUC020AW	AUC030AW
1000mm	AUC020BW	AUC030BW

- Arched aprons provide a work area from a seated position.
- 2" high front and rear rails.
- Actual depth 7/8" less than nominal.

MISCELLANEOUS ITEMS

Support Legs

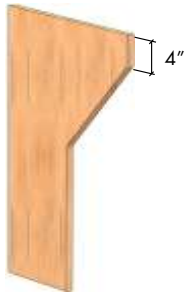

Depth	Standing Height	Sitting Height	ADA Height
28"	GLD1028W	GLD2028W	GLD3028W
29"	GLD1029W	GLD2029W	GLD3029W
34"	GLD1034W	GLD2034W	GLD3034W
35"	GLD1035W	GLD2035W	GLD3035W
46"	GLD1046W	GLD2046W	GLD3046W
52"	GLD1052W	GLD2052W	GLD3052W
58"	GLD1058W	GLD2058W	GLD3058W

- Legs are used to support Island counter tops or Aprons where base cabinets are not required.
- 3/4" thick.
- Nominal depths shown in chart.
- Actual depths 1-3/4" less than nominal.

Depth	Standing Height	Sitting Height	ADA Height
22"	GLA1022W	GLA2022W	GLA3022W
23"	GLA1023W	GLA2023W	GLA3023W
29"	GLA1029W	GLA2029W	GLA3029W
35"	GLA1035W	GLA2035W	GLA3035W

- Legs are used to support counter tops or Aprons where base cabinets are not required.
- Lower portion depth is half of overall depth.
- 3/4" thick.
- Nominal depths shown in chart.
- Actual depths 7/8" less than nominal.

Gable Legs



Depth	Standing Height	Sitting Height	ADA Height
22"	GLS1022W	GLS2022W	GLS3022W
23"	GLS1023W	GLS2023W	GLS3023W
29"	GLS1029W	GLS2029W	GLS3029W
35"	GLS1035W	GLS2035W	GLS3035W

- Gable Legs are used to support counter tops or Aprons where base cabinets are not required.
- Complete with finished wood cleats.
- 3/4" thick.
- Nominal depths shown in chart.
- Actual depths 7/8" less than nominal.

Table Legs



Height	Item Number
28-3/4"	3200000W
34-3/4"	3100000W
31-3/4"	3500000W

- Table Legs are used to support counter tops where base cabinets are not present.
- Leveling bolts and 4" high shoes are included.
- 2-1/8" wide by 2-1/8" deep.

MISCELLANEOUS ITEMS

Full Access Island Service Drops

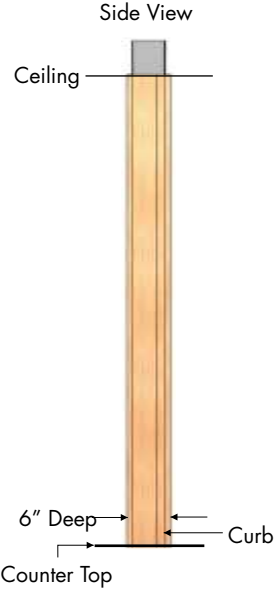
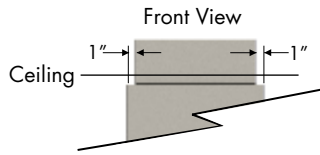

Height	Item Number
68"	SDP1368W
73"	SDP1373W
78"	SDP1378W
90"	SDP1390W

- Use to carry utilities from the counter top up through the ceiling.
- Service Drop offers full height (from counter top to ceiling) access to services.
- Front panel attaches with Keku clips.

Full Access Wall Service Drops

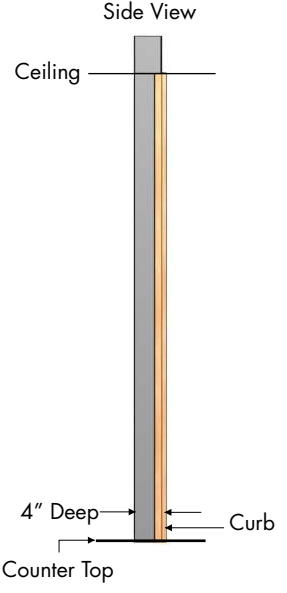
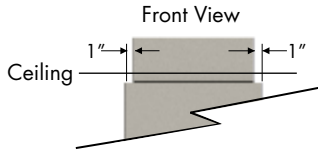

Height	Item Number
68"	SDP1468W
73"	SDP1473W
78"	SDP1478W
90"	SDP1490W

- Use to carry utilities from the counter top up through the ceiling.
- Service Drop offers full height (from counter top to ceiling) access to services.
- Front panel attaches with Keku clips.
- Designed to fit on a 22" wide x 5" high x 4" deep curb.

All dimensions and sizes shown are nominal. Specifications and details are based on product information at the time of printing and may change at any time without notice. Mott Manufacturing reserves the right to change dimensions, specifications and manufacturing details at any time without notice.

MISCELLANEOUS ITEMS

Service Drops



Top View

Height	6" Deep		8" Deep	
	12" Wide	24" Wide	12" Wide	24" Wide
78"	SDP3078W	SDP4078W	SDP1078W	SDP2078W
90"	SDP3090W	SDP4090W	SDP1090W	SDP2090W

- Use to carry utilities from the counter top up through the ceiling.
- For Wall and Island applications.
- Each assembly consists of two 12" high fixed upper and lower panels and a removable center panel.
- 78" high service drop has 54" center lift off panel.
- 90" high service drop has 66" center lift off panel.

Sigma Flex™ Wood Shelves



Width	Wood Shelves					
	6"Depth	8"Depth	10"Depth	12"Depth	14" Deep	18" Deep
24"	FSH0624W	FSH0824W	FSH1024W	FSH1224W	FSH1424W	FSH1824W
30"	FSH0630W	FSH0830W	FSH1030W	FSH1230W	FSH1430W	FSH1830W
36"	FSH0636W	FSH0836W	FSH1036W	FSH1236W	FSH1436W	FSH1836W
42"	FSH0642W	FSH0842W	FSH1042W	FSH1242W	FSH1442W	FSH1842W
48"	FSH0648W	FSH0848W	FSH1048W	FSH1248W	FSH1448W	FSH1848W
54"	FSH0654W	FSH0854W	FSH1054W	FSH1254W	FSH1454W	FSH1854W
60"	FSH0660W	FSH0860W	FSH1060W	FSH1260W	FSH1460W	FSH1860W

- Shelf suitable for any Sigma Flex™ support structure or Sigma Cart™.
- Attach to shelf brackets with screws (screws not included).
- Nominal width.
- For wood shelving options see page N8.

Sigma Flex™ Shelf Retainer Rods



≤ 30" wide assemblies



>30" wide assemblies

Width	Wood Shelves		Retainer Rod Parts
	Powder Coated	Stainless Steel	
24"	PRR0024-FXW	SRR0024-FXW	1 rod & 2 turrets
30"	PRR0030-FXW	SRR0030-FXW	1 rod & 2 turrets
36"	PRR0036-FXW	SRR0036-FXW	1 rod & 3 turrets
42"	PRR0042-FXW	SRR0042-FXW	1 rod & 3 turrets
48"	PRR0048-FXW	SRR0048-FXW	1 rod & 3 turrets
54"	PRR0054-FXW	SRR0054-FXW	1 rod & 3 turrets
60"	PRR0060-FXW	SRR0060-FXW	1 rod & 3 turrets
66"	PRR0066-FXW	SRR0066-FXW	1 rod & 4 turrets

- 1" high retainer rod (5/16" dia.) Prevents articles from falling off the shelf.
- Available in stainless steel or powder coated stainless steel and can be added to existing shelves.
- Threaded turrets includes hardware for mounting to shelf (shelf must have holes drilled to accept turrets).
- Ships loose.
- FXW at the end of the part numbers represents an option code.

MISCELLANEOUS ITEMS

Wood Shelving Options



Height	Back Lip	Front Lip	Back & Front Lip
1"	ARW1	AFW1	ABW1
2"	ARW2	AFW2	ABW2
3"	ARW3	AFW3	ABW3
4"	ARW4	AFW4	ABW4

- Height of the lip is measured from the top of the shelf to the top of the lip. Lip is 3/4" thick.
- Shelves are 1" thick.

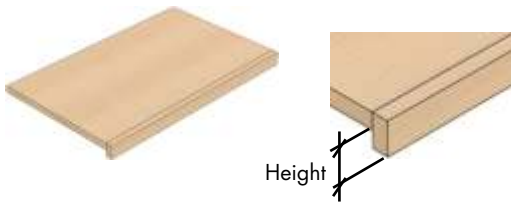

Height	Front Valance
1"	FV1
2"	FV2
3"	FV3
4"	FV4

- Height of the valance is measured from the bottom of the shelf to the bottom of the valance. Valance is 3/4" thick.
- Shelves are 1" thick.



Height	Bookends
4"	BE4
5"	BE5
6"	BE6

- Height of the bookends are measured from the top of the shelf to the top of the bookends. Bookends are 3/4" thick.
- Shelves are 1" thick.



Height	Bookends with Raised Lip at Back
4"	3BE4
5"	3BE5
6"	3BE6

- Height of the bookends and rear lip are measured from the top of the shelf to the top of the bookends or lip. Bookends and rear lip are 3/4" thick.
- Shelves are 1" thick.



Bookend with Raised Lip at Back Bookend Height	Raised Lip at Back		
	1"H	2"H	3"H
4"	BR41	BR42	BR43
5"	BR51	BR52	BR53
6"	BR61	BR62	BR63

- Height of the bookends and rear lip are measured from the top of the shelf to the top of the bookends or lip. Bookends and rear lip are 3/4" thick.
- Shelves are 1" thick.

MISCELLANEOUS ITEMS

Finished Back Panels



Width	Standing Height	Sitting Height	ADA Height
15"	FBP1015W	FBP2015W	FBP6015W
18"	FBP1018W	FBP2018W	FBP6018W
24"	FBP1024W	FBP2024W	FBP6024W
30"	FBP1030W	FBP2030W	FBP6030W
36"	FBP1036W	FBP2036W	FBP6036W
42"	FBP1042W	FBP2042W	FBP6042W
48"	FBP1048W	FBP2048W	FBP6048W

- Finished Back Panels are used to close off the back of a base cabinet when the back is in plain view.

Extended Finished Back Panels



Width	Standing Height			Sitting Height			ADA Height		
	6"Return	8"Return	12"Return	6"Return	8"Return	12"Return	6"Return	8"Return	12"Return
15"	FEA1506W	FEA1508W	FEA1512W	FEC1506W	FEC1508W	FEC1512W	FED1506W	FED1508W	FED1512W
18"	FEA1806W	FEA1808W	FEA1812W	FEC1806W	FEC1808W	FEC1812W	FED1806W	FED1808W	FED1812W
24"	FEA2406W	FEA2408W	FEA2412W	FEC2406W	FEC2408W	FEC2412W	FED2406W	FED2408W	FED2412W
30"	FEA3006W	FEA3008W	FEA3012W	FEC3006W	FEC3008W	FEC3012W	FED3006W	FED3008W	FED3012W
36"	FEA3606W	FEA3608W	FEA3612W	FEC3606W	FEC3608W	FEC3612W	FED3606W	FED3608W	FED3612W
42"	FEA4206W	FEA4208W	FEA4212W	FEC4206W	FEC4208W	FEC4212W	FED4206W	FED4208W	FED4212W
48"	FEA4806W	FEA4808W	FEA4812W	FEC4806W	FEC4808W	FEC4812W	FED4806W	FED4808W	FED4812W
60"	FEA6006W	FEA6008W	FEA6012W	FEC6006W	FEC6008W	FEC6012W	FED6006W	FED6008W	FED6012W
72"	FEA7206W	FEA7208W	FEA7212W	FEC7206W	FEC7208W	FEC7212W	FED7206W	FED7208W	FED7212W

- Extended Finished Back Panels are used to close off the back of a base cabinet when the back is in plain view.

Wall Cabinet Furring Panels



Width	14" Deep	18" Deep	22" Deep
18"	FPS1018W	FPS2018W	FPS3018W
24"	FPS1024W	FPS2024W	FPS3024W
30"	FPS1030W	FPS2030W	FPS3030W
36"	FPS1036W	FPS2036W	FPS3036W
42"	FPS1042W	FPS2042W	FPS3042W
48"	FPS1048W	FPS2048W	FPS3048W
60"	FPS1060W	FPS2060W	FPS3060W
72"	FPS1072W	FPS2072W	FPS3072W
96"	FPS1096W	FPS2096W	FPS3096W
1000mm	FPS100BW	FPS200BW	FPS300BW

- Wall Cabinet Furring Panels are used to close off the area between the top of a wall cabinet and the ceiling.
- Wall Cabinet Furring Panels are 7/8" shorter in depth than the standard depth of the cabinet.
- 24" high.
- Depth dimensions are nominal.

MISCELLANEOUS ITEMS

Double Sided Student Workstation

- Double Sided Student Workstations are designed to be used from both sides.
- Dimensions of 58" wide by 46" deep are available in sitting height (28-3/4") and standing height (34-3/4").
- Cabinet configurations are identical on each side of the assembly and are separated by 10" wide filler and include two pass through book compartments.
- Standing height workstations cabinets are 30" wide by 36" high by 18" deep.
- Sitting height workstations cabinets are 30" wide by 30" high by 18" deep.
- A variety of assemblies are available with different cabinet configurations. Please contact Mott for details.
- Counter tops are not included.

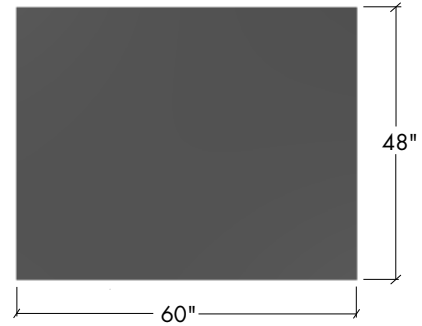

Required Counter Top Detail

Height	Item Number
28-3/4"	DSW0200W
34-3/4"	DSW0100W



Height	Item Number
28-3/4"	DSW0220W
34-3/4"	DSW0120W



Height	Item Number
28-3/4"	DSW0210W
34-3/4"	DSW0110W

MISCELLANEOUS ITEMS

Double Sided Student Workstation

- Double Sided Student Workstations are designed to be used from both sides.
- Dimensions of 58" wide by 46" deep are available in sitting height (28-3/4") and standing height (34-3/4").
- Cabinet configurations are identical on each side of the assembly and are separated by 10" wide filler and include two pass through book compartments.
- Standing height workstations cabinets are 30" wide by 36" high by 18" deep.
- Sitting height workstations cabinets are 30" wide by 30" high by 18" deep.
- A variety of assemblies are available with different cabinet configurations. Please contact Mott for details.
- Counter tops are not included.

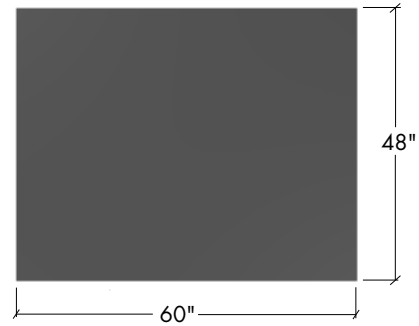

Required Counter Top Detail

Height	Item Number
28-3/4"	DSW0230W
34-3/4"	DSW0130W



Height	Item Number
28-3/4"	DSW0231W
34-3/4"	DSW0131W



Height	Item Number
28-3/4"	DSW0232W
34-3/4"	DSW0132W

MISCELLANEOUS ITEMS

Quad Student Workstation

- Quad Student Workstations are designed to be used from all sides.
- Dimensions of 58" wide by 58" deep are available in sitting height (28-3/4") and standing height (34-3/4").
- Cabinet configurations are identical on each side of the assembly and include accessible center space.
- Cabinet dimensions are 24" wide by 20" high by 15" deep.
- Quantity of four (one per side) 120volt, 20 amperage electrical receptacles are optional.
- A variety of assemblies are available with different cabinet configurations. Please contact Mott for details.
- Cabinets have a removable back in order to access a 19" wide by 10-1/4" high cutout in pedestal.
- Counter tops are not included.



Workstation with electrical receptacles shown

Height	Plain	With Electrical
28-3/4" High	QSW0200W	QSWE200W
34-3/4" High	QSW0100W	QSWE100W

Height	Plain	With Electrical
28-3/4" High	QSW0220W	QSWE220W
34-3/4" High	QSW0120W	QSWE120W

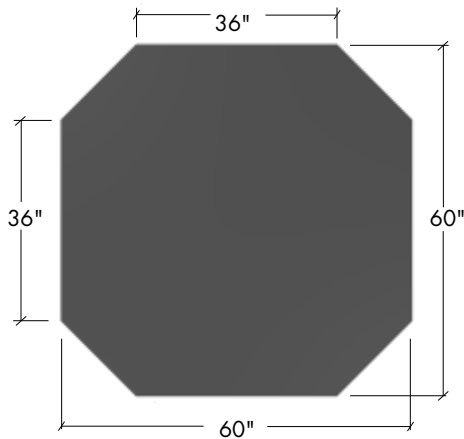

Required Counter Top Detail

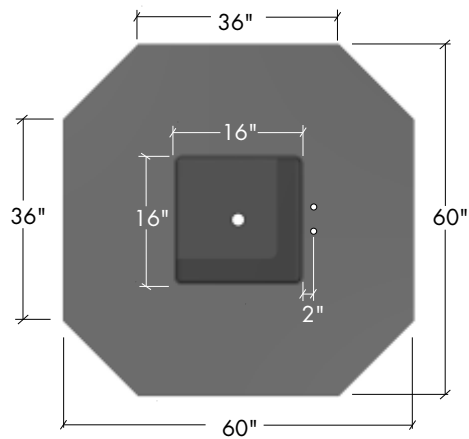

Required Counter with Sink Top Detail

- Maximum sink size is 16" x 16" with fixture holes located 2" from any side of the sink edge to center of fixture hole.

MISCELLANEOUS ITEMS

Quad Student Workstation

- Quad Student Workstations are designed to be used from all sides.
- Dimensions of 58" wide by 58" deep are available in sitting height (28-3/4") and standing height (34-3/4").
- Cabinet configurations are identical on each side of the assembly and include accessible center space.
- Cabinet dimensions are 24" wide by 20" high by 15" deep.
- Quantity of four (one per side) 120volt, 20 amperage electrical receptacles are optional.
- A variety of assemblies are available with different cabinet configurations. Please contact Mott for details.
- Cabinets have a removable back in order to access a 19" wide by 10-1/4" high cutout in pedestal.
- Counter tops are not included.



Workstation with electrical receptacles shown

Height	Plain	With Electrical
28-3/4" High	QSW0212W	QSWE212W
34-3/4" High	QSW0112W	QSWE112W

Height	Plain	With Electrical
28-3/4" High	QSW0211W	QSWE211W
34-3/4" High	QSW0110W	QSWE110W

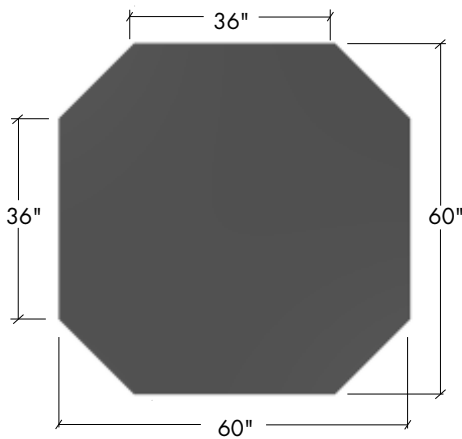

Required Counter Top Detail

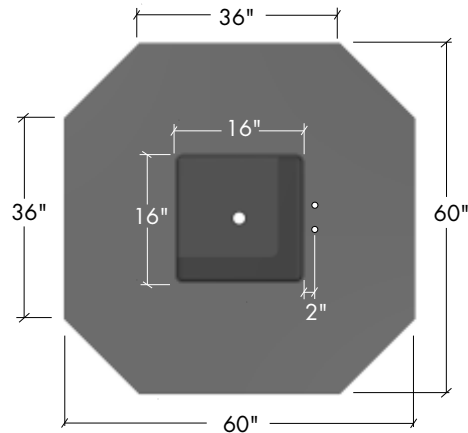

Required Counter with Sink Top Detail

- Maximum sink size is 16" x 16" with fixture holes located 2" from any side of the sink edge to center of fixture hole.

MISCELLANEOUS ITEMS

Two & Four Student Cabinet Storage Workstations

These are samples of some of the student storage workstations Mott offers. A variety of assemblies are available with different cabinet configurations in various dimensions. For additional information and help in planning contact Mott Manufacturing.



Demonstration Stations

These are samples of some of the demonstration workstations Mott offers. A variety of assemblies are available with different cabinet configurations in various dimensions. For additional information and help in planning contact Mott Manufacturing.



MISCELLANEOUS ITEMS OPTIONS

Option Code	Description
00	Modified door/drawer configuration
01	Full extension drawer runners
02	Label holders on all doors/drawers
03	Numeric or alpha identification disks on all doors/drawers (customer details required)
07	Cut-outs for electrical and/or plumbing services (customer drawing required)
09	Stainless steel waste flap
10	One fixed drawer divider per drawer (centered in drawer)
11	Multiple drawer dividers per drawer (customer drawing required)
12	Pull out writing board - all cold rolled steel*
13	Pull out writing board - cold rolled steel & high pressure laminate writing surface*
14	Ventilation grill in toe kick base
16	Ship handles not installed
17	Nylon levelers
19	Replaces standard drawer(s) with full width drawer(s) on 5" high apron
26	200 lbs full extension drawer runners
48	Keyboard tray (replaces drawer)
71	Toe kick - front & left side
79	Other customer specified base or toe kick
OLD	Actual Depth
PFE	Pull out writing board on full extension runners*
PW	Pre-wired (option code not to be used for fume hoods, customer details required)
SK	Skid item
S01	Full extension soft close drawer runners
S26	200lbs full extension soft close drawers runners