

STEEL CASEWORK MISCELLANEOUS ITEMS - BASE FILLER PANELS

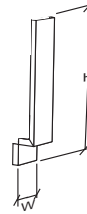

Front Filler Scribes - Standing Height

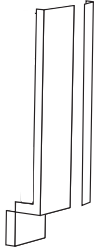

- The Front Filler Scribe is used to close a space between a base cabinet and a wall.
- A double angle is provided to enclose the raw edge of the panel.
- Filler panels can be ordered in 1" increments, up to 24" wide. Change the last two digits to the dimension required.
- 34-3/4" high right hand shown.

Width	Right Hand	Left Hand
1"	FFR1001	FFL1001
2"	FFR1002	FFL1002
4"	FFR1004	FFL1004
6"	FFR1006	FFL1006
8"	FFR1008	FFL1008
10"	FFR1010	FFL1010
12"	FFR1012	FFL1012

Front Filler Scribes - Sitting Height



- The Front Filler Scribe is used to close a space between a base cabinet and a wall.
- A double angle is provided to enclose the raw edge of the panel.
- Filler panels can be ordered in 1" increments, up to 24" wide. Change the last two digits to the dimension required.
- 28-3/4" high right hand shown.

Width	Right Hand	Left Hand
1"	FFR2001	FFL2001
2"	FFR2002	FFL2002
4"	FFR2004	FFL2004
6"	FFR2006	FFL2006
8"	FFR2008	FFL2008
10"	FFR2010	FFL2010
12"	FFR2012	FFL2012

Front Filler Scribes - ADA Height



- The Front Filler Scribe is used to close a space between a base cabinet and a wall.
- A double angle is provided to enclose the raw edge of the panel.
- Filler panels can be ordered in 1" increments, up to 24" wide. Change the last two digits to the dimension required.
- 31-3/4" high right hand shown.

Width	Right Hand	Left Hand
1"	FFR8001	FFL8001
2"	FFR8002	FFL8002
4"	FFR8004	FFL8004
6"	FFR8006	FFL8006
8"	FFR8008	FFL8008
10"	FFR8010	FFL8010
12"	FFR8012	FFL8012

Front Filler Panels



- The Front Filler Panel is used to close a space between two base cabinets.
- Available in sitting height (28-3/4"), ADA height (31-3/4") and standing height (34-3/4").
- Filler panels can be ordered in 1" increments, up to 24" wide. Change the last two digits to the dimension required.

Width	Sitting Hgt	Standing Hgt	ADA Hgt
1"	FFC2001	FFC1001	FFC8001
2"	FFC2002	FFC1002	FFC8002
4"	FFC2004	FFC1004	FFC8004
6"	FFC2006	FFC1006	FFC8006
8"	FFC2008	FFC1008	FFC8008
10"	FFC2010	FFC1010	FFC8010
12"	FFC2012	FFC1012	FFC8012
24"	FFC2024	FFC1024	FFC8024

Corner Filler Panels

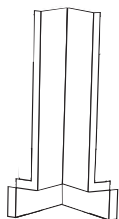

- The Corner Filler Panel is used to close a corner space between two base cabinets.
- Available in sitting height (28-3/4"), ADA height (31-3/4") and standing height (34-3/4").
- Filler panels can be ordered in 1" increments, up to 24" wide. Change the last two digits to the dimension required.

Width	Sitting Hgt	Standing Hgt	ADA Hgt
1" x 1"	CFC2001	CFC1001	CFC8001
2" x 2"	CFC2002	CFC1002	CFC8002
4" x 4"	CFC2004	CFC1004	CFC8004
6" x 6"	CFC2006	CFC1006	CFC8006

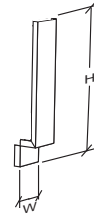

**STEEL CASEWORK
MISCELLANEOUS ITEMS - BASE FILLER PANELS**

Corner Filler Panel Scribes

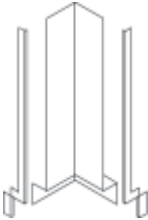

- The Corner Filler Panel is used to close a corner space between two base cabinets.
- Two double angles are provided to enclose the raw edges of the panel.
- Available in sitting height (28-3/4"), ADA height (31-3/4") and standing height (34-3/4").

Width	Sitting Hgt	Standing Hgt	ADA Hgt
3" x 3"	CFS2003	CFS1003	CFS8003
6" x 6"	CFS2006	CFS1006	CFS8006

Adjustable Corner Fillers

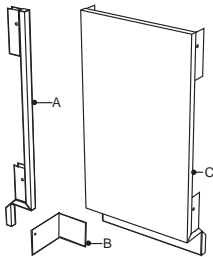

- The items A, B, & C combine to make the Adjustable Corner Filler Panel.
- This panel is used to close a corner space between two base cabinets. It offers the added advantage of being adjustable to enclose spaces up to 14" wide.
- Available in sitting height (28-3/4"), ADA height (31-3/4") and standing height (34-3/4").

Height	Item A	Item B	Item C
28-3/4"	FFC2001	9900001	FFC2018
34-3/4"	FFC1001	9900001	FFC1018
31-3/4"	FFC8001	9900001	FFC8018

End Cover Panel Scribes

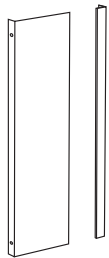

- The End Cover Panel Scribes are used to close spaces between the back of a base cabinet and a wall. The Scribe feature allows for easy width adjustment in the field.
- Filler panels can be ordered in 1" increments, up to 24" wide. Change the last two digits to the dimension required.
- Available in sitting height (28-3/4"), ADA height (31-3/4") and standing height (34-3/4").

Width	Sitting Hgt	Standing Hgt	ADA Hgt
1"	ECS2001	ECS1001	ECS5001
4"	ECS2004	ECS1004	ECS5004
7"	ECS2007	ECS1007	ECS5007
8"	ECS2008	ECS1008	ECS5008
10"	ECS2010	ECS1010	ECS5010
11"	ECS2011	ECS1011	ECS5011
120mm	ECS200A	ECS100A	ECS500A
266mm	ECS200B	ECS100B	ECS500B

End Cover Channels



- The End Cover Channel performs the same task as the End Cover Panel Scribe but is of a fixed width.
- Filler panels can be ordered in 1" increments, up to 24" wide. Change the last two digits to the dimension required.
- Available in sitting height (28-3/4"), ADA height (31-3/4") and standing height (34-3/4").

Width	Sitting Hgt	Standing Hgt	ADA Hgt
1"	ECC2001	ECC1001	ECC5001
2"	ECC2002	ECC1002	ECC5002
4"	ECC2004	ECC1004	ECC5004
7"	ECC2007	ECC1007	ECC5007
13"	ECC2013	ECC1013	ECC5013
14"	ECC2014	ECC1014	ECC5014
120mm	ECC200A	ECC100A	ECC500A

STEEL CASEWORK MISCELLANEOUS ITEMS - PANELS & ANGLES

Finished Back Panels



- The Finished Back Panels are used to close off the back of a base cabinet when the back is in plain view.
- Available in sitting height (28-3/4"), ADA height (31-3/4") or standing height (34-3/4").
- Add option code 15 for a welded back on a cabinet.
- Filler panels can be ordered in 1" increments, up to 24" wide. Change the last two digits to the dimension required.

Width	Sitting Hgt	Standing Hgt	ADA Hgt
15"	FBP2015	FBP1015	FBP6015
18"	FBP2018	FBP1018	FBP6018
24"	FBP2024	FBP1024	FBP6024
30"	FBP2030	FBP1030	FBP6030
36"	FBP2036	FBP1036	FBP6036
42"	FBP2042	FBP1042	FBP6042
48"	FBP2048	FBP1048	FBP6048

Extended Finished Back Panels



Width	Standing Height			Sitting Height			ADA Height		
	4" Return	10" Return	18" Return	4" Return	10" Return	18" Return	4" Return	10" Return	18" Return
15"	FEA1504	FEA1510	FEA1518	FEC1504	FEC1510	FEC1518	FED1504	FED1510	FED1518
18"	FEA1804	FEA1810	FEA1818	FEC1804	FEC1810	FEC1818	FED1804	FED1810	FED1818
24"	FEA2404	FEA2410	FEA2418	FEC2404	FEC2410	FEC2418	FED2404	FED2410	FED2418
30"	FEA3004	FEA3010	FEA3018	FEC3004	FEC3010	FEC3018	FED3004	FED3010	FED3018
36"	FEA3604	FEA3610	FEA3618	FEC3604	FEC3610	FEC3618	FED3604	FED3610	FED3618
42"	FEA4204	FEA4210	FEA4218	FEC4204	FEC4210	FEC4218	FED4204	FED4210	FED4218
48"	FEA4804	FEA4810	FEA4818	FEC4804	FEC4810	FEC4818	FED4804	FED4810	FED4818
60"	FEA6004	FEA6010	FEA6018	FEC6004	FEC6010	FEC6018	FED6004	FED6010	FED6018
72"	FEA7204	FEA7210	FEA7218	FEC7204	FEC7210	FEC7218	FED7204	FED7210	FED7218

- The Extended Finished Back Panels are used to close off the back of a base cabinet when the back is in plain view.
- Available in sitting height (28-3/4"), ADA height (31-3/4") or standing height (34-3/4").
- Panels are available in 1" increments from 4" - 18". Change the last two digits to the dimension required.
- Corner gussets are welded into top and bottom corners.

Single Angles



Length	1" x 1"	2" x 2"
28 - 1/2"	SAG110C	SAG220C
31 - 1/2"	SAG110B	SAG220B
34 - 1/2"	SAG110A	SAG220A
18"	SAG1118	SAG2218
24"	SAG1124	SAG2224
36"	SAG1136	SAG2236
48"	SAG1148	SAG2248
60"	SAG1160	SAG2260
72"	SAG1172	SAG2272
84"	SAG1184	SAG2284

Double Angles



Length	1" x 1"
28 - 1/2"	DAG110C
31 - 1/2"	DAG110B
34 - 1/2"	DAG110A
12"	DAG1112
24"	DAG1124
30"	DAG1130
36"	DAG1136
42"	DAG1142
48"	DAG1148
60"	DAG1160
72"	DAG1172
84"	DAG1184

STEEL CASEWORK MISCELLANEOUS ITEMS - TALL FILLER PANELS

Tall Storage Corner Filler Scribes



- The Tall Corner Storage Filler Panel is used to close a corner space between two floor cabinets.
- The scribe feature allows for easy width adjustment in the field.
- Two double angles are provided to enclose the raw edges of the panel.

Width	84" High
3" x 3"	CFS3003
6" x 6"	CFS3006

Tall Filler Scribes



- The Tall Front Filler Scribe is used to close a space between a floor cabinet and a wall.
- A double angle is provided to enclose the raw edge of the panel.
- Filler panels can be ordered in 1" increments, up to 24" wide. Change the last two digits to the dimension required.
- 84" high right hand shown.

Width	Right Hand	Left Hand
1"	FFR3001	FFL3001
2"	FFR3002	FFL3002
4"	FFR3004	FFL3004
6"	FFR3006	FFL3006
8"	FFR3008	FFL3008
10"	FFR3010	FFL3010
12"	FFR3012	FFL3012

Tall Front Filler Panels



- The Tall Front Filler Panel is used to close a space between two floor cabinets.
- Filler panels can be ordered in 1" increments, up to 24" wide. Change the last two digits to the dimension required.
- 84" high.

Width	84" High
1"	FFC3001
2"	FFC3002
3"	FFC3003
4"	FFC3004
8"	FFC3008
10"	FFC3010
12"	FFC3012
24"	FFC3024

Tall End Cover Panel Scribes

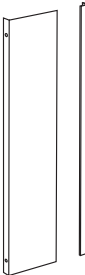

- The Tall End Cover Panel Scribes are used to close spaces between the back of a floor cabinet and a wall.
- The Scribe feature allows for easy width adjustment in the field.
- Filler panels can be ordered in 1" increments, up to 24" wide. Change the last two digits to the dimension required.
- 84" high.

Width	84" High
1"	ECS3001
2"	ECS3002
3"	ECS3003
4"	ECS3004
7"	ECS3007
8"	ECS3008

Tall End Cover Channels

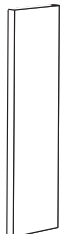

- The Tall End Cover Channel performs the same task as the End Cover Panel Scribe but is of a fixed width.
- Filler panels can be ordered in 1" increments, up to 24" wide. Change the last two digits to the dimension required.
- 84" high.

Width	84" High
1"	ECC3001
2"	ECC3002
3"	ECC3003
4"	ECC3004
7"	ECC3007
8"	ECC3008

STEEL CASEWORK MISCELLANEOUS ITEMS - WALL FILLER PANELS

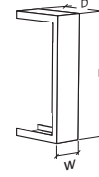

Front Wall Filler Scribes - 14" Deep



- The Wall Filler Scribe is used to close a space between a wall cabinet and a wall. It can be cut to fit gaps of various sizes.
- A double angle is provided to enclose the raw edge of the panel.
- Filler panels can be ordered in 1" increments, up to 24" wide. Change the last two digits to the dimension required.
- Filler panels can be ordered in 1" increments, up to 24" wide. Change the last two digits to the dimension required.

Width	24" High	30" High	36" High	48" High
1"	WFS5301	WFS6301	WFS7301	WFS8301
2"	WFS5302	WFS6302	WFS7302	WFS8302
3"	WFS5303	WFS6303	WFS7303	WFS8303
4"	WFS5304	WFS6304	WFS7304	WFS8304
6"	WFS5306	WFS6306	WFS7306	WFS8306
8"	WFS5308	WFS6308	WFS7308	WFS8308
10"	WFS5310	WFS6310	WFS7310	WFS8310
12"	WFS5312	WFS6312	WFS7312	WFS8312
15"	WFS5315	WFS6315	WFS7315	WFS8315
18"	WFS5318	WFS6318	WFS7318	WFS8318
24"	WFS5324	WFS6324	WFS7324	WFS8324

Front Wall Fillers - 14" Deep

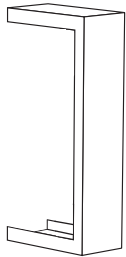

- The Wall Filler Scribe is used to close a space between two wall cabinets.
- Filler panels can be ordered in 1" increments, up to 24" wide. Change the last two digits to the dimension required.

Width	24" High	30" High	36" High	48" High
1"	WFP5301	WFP6301	WFP7301	WFP8301
2"	WFP5302	WFP6302	WFP7302	WFP8302
3"	WFP5303	WFP6303	WFP7303	WFP8303
4"	WFP5304	WFP6304	WFP7304	WFP8304
6"	WFP5306	WFP6306	WFP7306	WFP8306
8"	WFP5308	WFP6308	WFP7308	WFP8308
10"	WFP5310	WFP6310	WFP7310	WFP8310
12"	WFP5312	WFP6312	WFP7312	WFP8312
15"	WFP5315	WFP6315	WFP7315	WFP8315
18"	WFP5318	WFP6318	WFP7318	WFP8318
24"	WFP5324	WFP6324	WFP7324	WFP8324

Front Wall Filler Scribes - 18" Deep

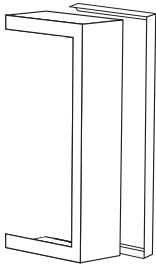

- The Wall Filler Scribe is used to close a space between a wall cabinet and a wall. It can be cut to fit gaps of various sizes.
- A double angle is provided to enclose the raw edge of the panel.
- Filler panels can be ordered in 1" increments, up to 24" wide. Change the last two digits to the dimension required.

Width	24" High	30" High	36" High	48" High
1"	WFS5201	WFS6201	WFS7201	WFS8201
2"	WFS5202	WFS6202	WFS7202	WFS8202
3"	WFS5203	WFS6203	WFS7203	WFS8203
4"	WFS5204	WFS6204	WFS7204	WFS8204
6"	WFS5206	WFS6206	WFS7206	WFS8206
8"	WFS5208	WFS6208	WFS7208	WFS8208
10"	WFS5210	WFS6210	WFS7210	WFS8210
12"	WFS5212	WFS6212	WFS7212	WFS8212
18"	WFS5218	WFS6218	WFS7218	WFS8218
19"	WFS5219	WFS6219	WFS7219	WFS8219
24"	WFS5224	WFS6224	WFS7224	WFS8224

Front Wall Fillers - 18" Deep

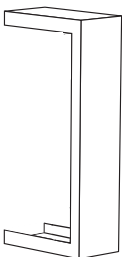

- The Wall Filler Scribe is used to close a space between two wall cabinets.
- Filler panels can be ordered in 1" increments, up to 24" wide. Change the last two digits to the dimension required.

Width	24" High	30" High	36" High	48" High
1"	WFP5201	WFP6201	WFP7201	WFP8201
2"	WFP5202	WFP6202	WFP7202	WFP8202
3"	WFP5203	WFP6203	WFP7203	WFP8203
4"	WFP5204	WFP6204	WFP7204	WFP8204
6"	WFP5206	WFP6206	WFP7206	WFP8206
8"	WFP5208	WFP6208	WFP7208	WFP8208
10"	WFP5210	WFP6210	WFP7210	WFP8210
12"	WFP5212	WFP6212	WFP7212	WFP8212
18"	WFP5218	WFP6218	WFP7218	WFP8218
19"	WFP5219	WFP6219	WFP7219	WFP8219
24"	WFP5224	WFP6224	WFP7224	WFP8224

STEEL CASEWORK MISCELLANEOUS ITEMS - DUST CAPS

Sloping Dust Caps

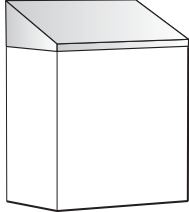

- The Sloping Dust Caps are used as a housekeeping aid on top of wall and floor cabinets.
- 8-3/8" high.

Overlay Corner Dust Caps

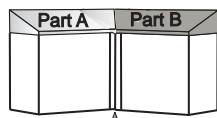

Front Wall Fillers

- The Overlay Corner Dust Caps are designed to close the corner space left by two wall cabinets. They are used in conjunction with a Sloping Dust Cap.
- 8-3/8" high.
- Order Overlay Corner Dust Cap based on cabinet width. Extra long sloping dust cap required see below to order.
- Cabinets must be equal depth.
- Order Front Wall Filler (WFP or WFS) in conjunction with an Overlay Corner Dust Cap.
- When ordering Overlay Corner Dust Caps, always use left hand (Part A) side to be the corner overlaying dust cap.

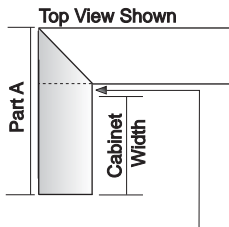

1" Front Wall Filler (WFS or WFP)

Top View Shown

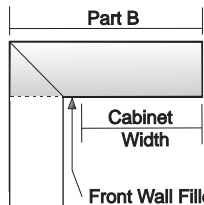

- Order Overlay Corner Dust Cap based on cabinet width. Extra long Sloping Dust Cap required.

Front Wall Filler (WFS or WFP)

Corner Wall Cabinet Dust Caps

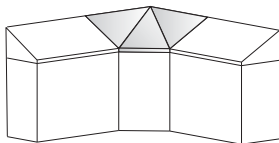

- The Corner Wall Cabinet Dust Caps are used as a housekeeping aid on top of Corner Wall Cabinets.
- 8-3/8" high.

Width	14" Deep	18" Deep	22" Deep
15"	SDC0315	SDC0215	SDC0115
18"	SDC0318	SDC0218	SDC0118
24"	SDC0324	SDC0224	SDC0124
30"	SDC0330	SDC0230	SDC0130
36"	SDC0336	SDC0236	SDC0136
42"	SDC0342	SDC0242	SDC0142
48"	SDC0348	SDC0248	SDC0148
60"	SDC0360	SDC0260	SDC0160
72"	SDC0372	SDC0272	SDC0172
513mm	SDC030A	SDC020A	SDC010A
1000mm	SDC030B	SDC020B	SDC010B

Part A			
Cabinet Width	14" Deep	18" Deep	22" Deep
15"	CDL0315	CDL0215	CDL0115
18"	CDL0318	CDL0218	CDL0118
24"	CDL0324	CDL0224	CDL0124
30"	CDL0330	CDL0230	CDL0130
36"	CDL0336	CDL0236	CDL0136
42"	CDL0342	CDL0242	CDL0142
48"	CDL0348	CDL0248	CDL0148
60"	CDL0360	CDL0260	CDL0160
72"	CDL0372	CDL0272	CDL0172
513mm	CDL030A	CDL020A	CDL010A
1000mm	CDL030B	CDL020B	CDL010B

Part B			
Cabinet Width	14" Deep	18" Deep	22" Deep
15"	CDR0315	CDR0215	CDR0115
18"	CDR0318	CDR0218	CDR0118
24"	CDR0324	CDR0224	CDR0124
30"	CDR0330	CDR0230	CDR0130
36"	CDR0336	CDR0236	CDR0136
42"	CDR0342	CDR0242	CDR0142
48"	CDR0348	CDR0248	CDR0148
60"	CDR0360	CDR0260	CDR0160
72"	CDR0372	CDR0272	CDR0172
513mm	CDR030A	CDR020A	CDR010A
1000mm	CDR030B	CDR020B	CDR010B

Depth	Item Number
14"	CDC0300
18"	CDC0200

Sloping Dust Cap Scribes



- The scribe feature allows for easy width adjustment in the field.
- 8-3/8" high.
- Sloping Dust Caps comes with two ECS Clips.

Right hand shown.

Right Hand				Left Hand		
Width	14" Deep	18" Deep	22" Deep	14" Deep	18" Deep	22" Deep
1"	SDR0301	SDR0201	SDR0101	SDL0301	SDL0201	SDL0101
2"	SDR0302	SDR0202	SDR0102	SDL0302	SDL0202	SDL0102
3"	SDR0303	SDR0203	SDR0103	SDL0303	SDL0203	SDL0103
4"	SDR0304	SDR0204	SDR0104	SDL0304	SDL0204	SDL0104
5"	SDR0305	SDR0205	SDR0105	SDL0305	SDL0205	SDL0105

STEEL CASEWORK MISCELLANEOUS ITEMS - APRONS & APRON SERVICE COVERS

Apron Units - 22" Deep

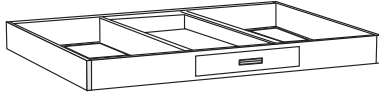

- Aprons provide a work area from a seated position.
- Aprons are available with or without drawers.
- 15" wide drawer.
- 3-3/4" high, three piece adjustable construction.

Apron Units 28" Deep

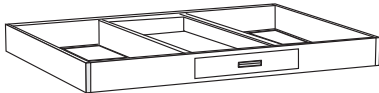

- Aprons provide a work area from a seated position.
- Aprons are available with or without drawers.
- 15" wide drawer.
- 3-3/4" high, three piece adjustable construction.

Apron Service Covers



- Apron Service Cover panels are used to conceal open spaces and services below aprons.
- Attaches to adjacent cabinets and meets the bottom of the apron.
- Assembly includes single angles for attachment to adjacent cabinets. Upper panel is removable to allow access to the services. The lower panel stays fixed in order to apply the coved base and overlapping the lower and upper panel allows to accommodate for uneven floors.
- Available for sitting height (25"), ADA height (28") and standing height (31") applications.

Welded Box Aprons - 22" Deep

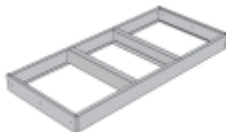

- Aprons provide a work area from a seated position.
- Aprons are available with or without drawers.
- 15" wide drawer.
- 3-3/4" high, one piece welded construction.

Width	Plain Front	With Drawers	# of Drawers
24"	AUC0124	AUA0124	1
30"	AUC0130	AUA0130	1
36"	AUC0136	AUA0136	1
42"	AUC0142	AUA0142	1
48"	AUC0148	AUA0148	2
54"	AUC0154	AUA0154	2
60"	AUC0160	AUA0160	2
66"	AUC0166	AUA0166	2
72"	AUC0172	AUA0172	2
513mm	AUC010A	AUA010A	1
1000mm	AUC010B	AUA010B	1

Width	Plain Front	With Drawers	# of Drawers
24"	AUC0424	AUA0424	1
30"	AUC0430	AUA0430	1
36"	AUC0436	AUA0436	1
42"	AUC0442	AUA0442	1
48"	AUC0448	AUA0448	2
54"	AUC0454	AUA0454	2
60"	AUC0460	AUA0460	2
66"	AUC0466	AUA0466	2
72"	AUC0472	AUA0472	2
513mm	AUC040A	AUA040A	1
1000mm	AUC040B	AUA040B	1

Width	Sitting Hgt	Standing Hgt	ADA Hgt
15"	SCP4015	SCP3015	SCP6015
18"	SCP4018	SCP3018	SCP6018
24"	SCP4024	SCP3024	SCP6024
30"	SCP4030	SCP3030	SCP6030
36"	SCP4036	SCP3036	SCP6036
42"	SCP4042	SCP3042	SCP6042
48"	SCP4048	SCP3048	SCP6048
54"	SCP4054	SCP3054	SCP6054
60"	SCP4060	SCP3060	SCP6060
66"	SCP4066	SCP3066	SCP6066
72"	SCP4072	SCP3072	SCP6072
513mm	SCP400A	SCP300A	SCP600A
1000mm	SCP400B	SCP300B	SCP600B

Width	Plain Front	With Drawers	# of Drawers
24"	BUC0124	BUA0124	1
30"	BUC0130	BUA0130	1
36"	BUC0136	BUA0136	1
42"	BUC0142	BUA0142	1
48"	BUC0148	BUA0148	2
54"	BUC0154	BUA0154	2
60"	BUC0160	BUA0160	2
66"	BUC0166	BUA0166	2
72"	BUC0172	BUA0172	2
513mm	BUC010A	BUA010A	1
1000mm	BUC010B	BUA010B	1

STEEL CASEWORK MISCELLANEOUS ITEMS - FRONT RAILS & FRONT RAIL SERVICE COVERS

Welded Box Aprons - 28" Deep

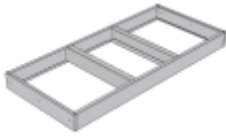

- Aprons provide a work area from a seated position.
- Aprons are available with or without drawers.
- 15" wide drawer.
- 3-3/4" high, one piece welded construction.

Width	Plain Front	With Drawers	# of Drawers
24"	BUC0424	BUA0424	1
30"	BUC0430	BUA0430	1
36"	BUC0436	BUA0436	1
42"	BUC0442	BUA0442	1
48"	BUC0448	BUA0448	2
54"	BUC0454	BUA0454	2
60"	BUC0460	BUA0460	2
66"	BUC0466	BUA0466	2
72"	BUC0472	BUA0472	2
513mm	BUC040A	BUA040A	1
1000mm	BUC040B	BUA040B	1

Front Rails

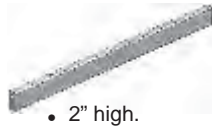

- Front Rails are commonly used to finish a space at a sitting area. They are used when a full frame apron is not required.
- In a "cut to fit" condition, use part number DAG000F for slip filler.

Width	3-3/4" H	2" H
18"	FRA0018	FRB0018
24"	FRA0024	FRB0024
30"	FRA0030	FRB0030
36"	FRA0036	FRB0036
42"	FRA0042	FRB0042
48"	FRA0048	FRB0048
54"	FRA0054	FRB0054
60"	FRA0060	FRB0060
66"	FRA0066	FRB0066
72"	FRA0072	FRB0072
513mm	FRA000A	FRB000A
1000mm	FRA000B	FRB000B

Double Angle Sleeves



Length	Item Number
3-3/4"	DAG000F
3"	DAG0003
2"	DAG0002

- Double Angle Sleeves are used to cover the cut edge of a "cut to fit" front rail.

Front Rail Service Covers



- Apron Service Cover panels are used to conceal open spaces and services below front rails.
- Attaches to adjacent cabinets and meets the bottom of the work surface.
- Assembly includes single angles for attachment to adjacent cabinets. Upper panel is removable to allow access to the services. The lower panel stays fixed in order to apply the covered base and overlapping the lower and upper panel allows to accommodate for uneven floors.
- Available in sitting height (28-3/4"), ADA height (31-3/4") and standing height (34-3/4").

Width	Sitting Hgt	Standing Hgt	ADA Hgt
15"	SCP2015	SCP1015	SCP5015
18"	SCP2018	SCP1018	SCP5018
24"	SCP2024	SCP1024	SCP5024
30"	SCP2030	SCP1030	SCP5030
36"	SCP2036	SCP1036	SCP5036
42"	SCP2042	SCP1042	SCP5042
48"	SCP2048	SCP1048	SCP5048
54"	SCP2054	SCP1054	SCP5054
60"	SCP2060	SCP1060	SCP5060
66"	SCP2066	SCP1066	SCP5066
72"	SCP2072	SCP1072	SCP5072
513mm	SCP200A	SCP100A	SCP500A
1000mm	SCP200B	SCP100B	SCP500B

STEEL CASEWORK MISCELLANEOUS ITEMS - TURRET SUPPORTS

Box Turret Supports

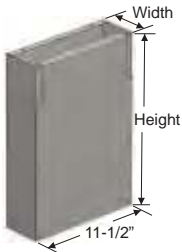

- Box Turret Supports are used to support reagent shelves. They may be used with front rails to form a rigid reagent support structure.
- The side panel is removable in order to access services.
- Counter top mounting clips are included.
- 11-1/2" deep.

Height	2" Wide	4" Wide	6" Wide
11"	9900062	9900010	9900012
17"	9900063	9900011	9900013

- Notched for a 3-3/4"H FRA rail.

Height	2" Wide	4" Wide	6" Wide
11"	9990062	9990010	9990012
17"	9990063	9990011	9990013

- Notched for a 2"H FRB rail.

Fixed Box Turret Support

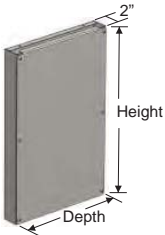

- Fixed Box Turret Supports are used to support reagent shelves. It may be used in conjunction with front rails to form a rigid reagent support structure.
- 2" wide.

Height	10" Deep	12" Deep	14" Deep	18" Deep
11"	BRS1010	BRS1012	BRS1014	BRS1018
14"	BRS2010	BRS2012	BRS2014	BRS2018
17"	BRS3010	BRS3012	BRS3014	BRS3018

Reagent Turret Supports

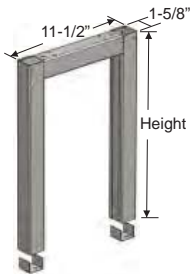

- Reagent Turret Supports are used to support reagent shelves.
- Stainless steel countertop mounting clips are included.
- 1-5/8" wide by 11-1/2" deep.

Height	Item Number
11"	9900006
17"	9900007
18"	9900008
19"	9900009

Adjustable Box Turret Supports



- Adjustable Box Turret End Supports are used to support reagent shelves. It may be used in conjunction with front rails to form a rigid reagent support structure.
- Adjustable slots are provided on one side.
- 2" wide.

Adjustable Box Turret End Supports				
Height	10" Deep	12" Deep	14" Deep	18" Deep
24"	BRE1010	BRE1012	BRE1014	BRE1018
34"	BRE2010	BRE2012	BRE2014	BRE2018



- Adjustable Box Turret Middle Supports are used to support reagent shelves. It may be used in conjunction with front rails to form a rigid reagent support structure.
- Adjustable slots are provided on both side.
- 2" wide.

Adjustable Box Turret Middle Supports				
Height	10" Deep	12" Deep	14" Deep	18" Deep
24"	BRM1010	BRM1012	BRM1014	BRM1018
34"	BRM2010	BRM2012	BRM2014	BRM2018

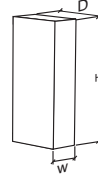

STEEL CASEWORK MISCELLANEOUS ITEMS - SUPPORT LEGS

Support Legs



- Support Legs are used to support island countertops or aprons where base cabinets are not required.
- Available in sitting height (28-3/4"), ADA height (31-3/4") and standing height (34-3/4").
- 1-1/2" wide.

Depth	Sitting Hgt	Standing Hgt	ADA Hgt
28"	GLD2028	GLD1028	GLD3028
29"	GLD2029	GLD1029	GLD3029
34"	GLD2034	GLD1034	GLD3034
35"	GLD2035	GLD1035	GLD3035
46"	GLD2046	GLD1046	GLD3046
52"	GLD2052	GLD1052	GLD3052
58"	GLD2058	GLD1058	GLD3058



- Support Legs are used to support island countertops or aprons where base cabinets are not required.
- Lower portion depth is half of overall depth.
- Support Legs come complete with wall mounting channel.
- Available in sitting height (28-3/4"), ADA height (31-3/4") and standing height (34-3/4").
- 1-1/2" wide.

Depth	Sitting Hgt	Standing Hgt	ADA Hgt
22"	GLA2022	GLA1022	GLA3022
23"	GLA2023	GLA1023	GLA3023
29"	GLA2029	GLA1029	GLA3029
35"	GLA2035	GLA1035	GLA3035

Support Legs

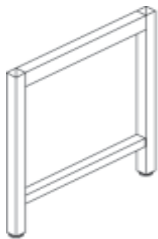

- Support Legs are used to support countertops where base cabinets are not required.
- Leveling bolts and PVC boots are included.
- Available in sitting height (28-3/4"), ADA height (31-3/4") and standing height (34-3/4").
- 2" X 2" tube.
- Suitable for use with TAC, TAA, TCC, TAB, TCB & TCE Tables.

Table Leg Assembly			
Depth	Sitting Hgt	Standing Hgt	ADA Hgt
22"	TLA2022	TLA1022	TLA5022
23"	TLA2023	TLA1023	TLA5023
28"	TLA2028	TLA1028	TLA5028
29"	TLA2029	TLA1029	TLA5029
35"	TLA2035	TLA1035	TLA5035



- Support Legs are used to support countertops where base cabinets are not required.
- Leveling bolts and PVC boots are included.
- Available in sitting height (28-3/4"), ADA height (31-3/4") and standing height (34-3/4").
- 2" X 2" tube.
- Suitable for use with TAC, TAA, TCC, TAB, TCB & TCE Tables.

Double Table Leg Assembly			
Depth	Sitting Hgt	Standing Hgt	ADA Hgt
46"	TLA2046	TLA1046	TLA5046
52"	TLA2052	TLA1052	TLA5052
58"	TLA2058	TLA1058	TLA5058

Table Legs



- Table Legs are used to support countertops where base cabinets are not required.
- Leveling bolts and PVC boots are included.
- Available in sitting height (28-3/4"), ADA height (31-3/4") and standing height (34-3/4").
- 2" x 2" tube.

Height	Item Number
28-3/4"	3200000
34-3/4"	3100000
31-3/4"	3500000

STEEL CASEWORK MISCELLANEOUS ITEMS - SUPPORT LEGS

Gable Legs



Depth	Sitting Hgt	Standing Hgt	ADA Hgt
22"	GLS2022	GLS1022	GLS3022
23"	GLS2023	GLS1023	GLS3023
29"	GLS2029	GLS1029	GLS3029
35"	GLS2035	GLS1035	GLS3035

- Gable Legs are used to support island countertops or aprons where base cabinets are not required.
- Gable Legs come complete with wall mounting channel.
- Available in sitting height (28-3/4"), ADA height (31-3/4") and standing height (34-3/4").
- 1-1/2" wide.

Service Legs



Depth	Sitting Hgt	Standing Hgt	ADA Hgt
7"	SLG2007	SLG1007	SLG3007
11"	SLG2011	SLG1011	SLG3011
14"	SLG2014	SLG1014	SLG3014

- Service Legs are used to go behind cabinets when extra counter support is required.
- Service Legs can also be used by plumbers to attach piping within the service chase.
- Each assembly comes with 3/8" spring nuts & bolts.
- Available in sitting height (28-3/4"), ADA height (31-3/4") and standing height (34-3/4").

Under Counter Support Brackets

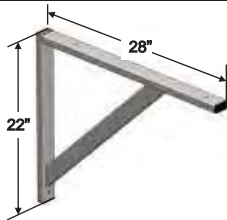

Item Number
CBS0001

- Under Counter Support Brackets are used to support counter tops.
- Suitable for 30" counter tops.
- Legs are 22" by 28" long welded from 1" x 2" 16 ga steel tube.

Stainless Steel Electrical Pedestal Boxes



Single Gang	Double Gang
PBS	PBD

- Double-faced deck-mounted stainless steel outlet box only.
- Complete with threaded nipple to attach to mounting surface.
- Cover plate and receptacles are not included.
- Not CSA or UL approved.

Wall Pilaster

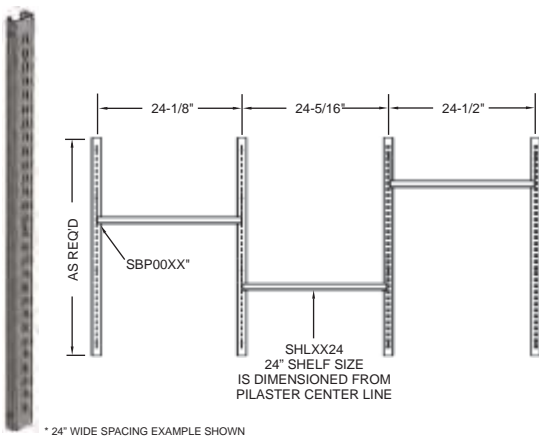

Height	Single Slotted	Double Slotted
18"	WPA1018	WPA0018
24"	WPA1024	WPA0024
30"	WPA1030	WPA0030
36"	WPA1036	WPA0036
42"	WPA1042	WPA0042
48"	WPA1048	WPA0048
60"	WPA1060	WPA0060
72"	WPA1072	WPA0072
84"	WPA1084	WPA0084
96"	WPA1096	WPA0096

- Pilasters only suitable for Sigma Frame™, Inverted Shelf Brackets, "SBP" and "WPA" components.
- Wall Pilasters should be mounted 1/2" on center wider than the shelf length.
- 1-5/8" wide by 13/16" deep.

STEEL CASEWORK MISCELLANEOUS ITEMS - SHELVES & SHELVING COMPONENTS

Steel Shelves

- Shelves are actual widths.
- Add 1" angles to shelves by using option codes:
 - AR (Rear Shelf Angle welded to shelf)
 - AF (Front Shelf Angle welded to shelf)
 - AB (Rear and Front Shelf Angle welded to shelf)



Shelf Angles

- Shelf angles can be added to steel shelves and are used to stop items from sliding off shelving.
- 2" high with a 1" return and notched for shelf brackets.
- Only suitable for SHL shelves.



Under Mount Shelf Task Lights



Width	10" Deep	12" Deep	14" Deep	16" Deep	18" Deep
24"	SHL1024	SHL1224	SHL1424	SHL1624	SHL1824
30"	SHL1030	SHL1230	SHL1430	SHL1630	SHL1830
36"	SHL1036	SHL1236	SHL1436	SHL1636	SHL1836
42"	SHL1042	SHL1242	SHL1442	SHL1642	SHL1842
48"	SHL1048	SHL1248	SHL1448	SHL1648	SHL1848
60"	SHL1060	SHL1260	SHL1460	SHL1660	SHL1860
513mm	SHL100A	SHL120A	SHL140A	SHL160A	SHL180A
1000mm	SHL100B	SHL120B	SHL140B	SHL160B	SHL180B
1512mm	SHL100C	SHL120C	SHL140C	SHL160C	SHL180C
2000mm	SHL100D	SHL120D	SHL140D	SHL160D	SHL180D

Width	Item Number
20"	RSA2120
24"	RSA2124
30"	RSA2130
36"	RSA2136
42"	RSA2142
48"	RSA2148
60"	RSA2160
72"	RSA2172

Length of Light	Item Number
14"	TLW0014
23"	TLW0023
36"	TLW0036
48"	TLW0048
59"	TLW0059

- **Order light a minimum 6" shorter than the shelf.**
- Low profile (.98" wide by 1.65" high) T5 fluorescent task light mounts to underside of the shelf.
- Shatterproof polycarbonate lens protects the lamp.
- Easily linkable in one continuous line using Flexible Connectors. 6" Flexible Connector comes standard with each light. See below to order longer Flexible Connectors.
- On-off rocker switch located on the side of the fixture.
- 8000 hour, cool white replaceable T5 lamp included.
- UL listed.
- Ships loose, includes Mott's mounting brackets.

Task Light Flexible Connectors



Width	Item Number
12"	LFC0012
24"	LFC0024
36"	LFC0036

- Flexible Connector allows to easily link T5 fluorescent lights in one continuous line.
- Ships loose.

STEEL CASEWORK MISCELLANEOUS ITEMS - SHELF BRACKETS

Shelf Brackets For Pilasters

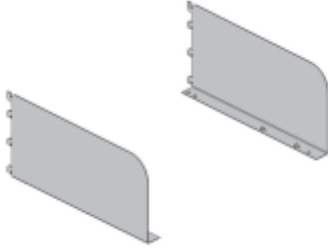

Depth	Item Number
10"	SBP0010
12"	SBP0012
14"	SBP0014
16"	SBP0016
18"	SBP0018

- Brackets only suitable for Sigma Frame™ and "WPA" components.
- Pair of shelf brackets are 6" high.
- Add option code NN for no alignment tabs on SBP brackets.

Inverted Shelf Brackets For Pilasters

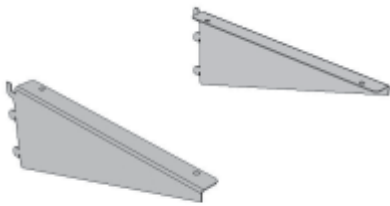

Depth	Item Number
10"	SBP1010
12"	SBP1012
14"	SBP1014
16"	SBP1016
18"	SBP1018

- Brackets only suitable for Sigma Frame™ and "WPA" components.
- Pair of shelf brackets are 4-1/4" high.

Hat Channel Shelf Brackets For Wall Struts

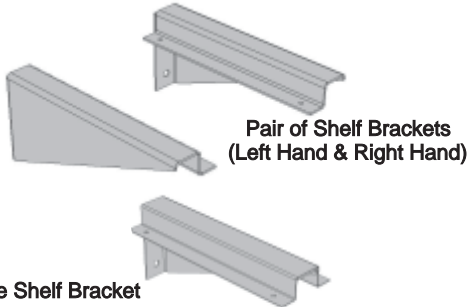

Depth	Pair Of Brackets	Middle Bracket
10"	TBP0010	TBD0010
12"	TBP0012	TBD0012
14"	TBP0014	TBD0014
16"	TBP0016	TBD0016
18"	TBP0018	TBD0018

- Steel shelf brackets suitable for Wall Struts.
- 5" high.

Shelf Brackets For Wall Struts

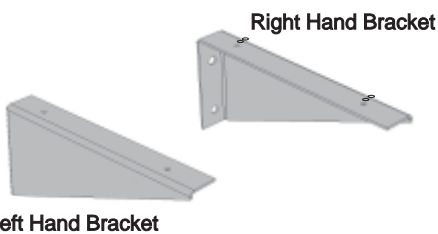

Depth	Left Hand Bracket	Right Hand Bracket
10"	TSL0010	TSR0010
12"	TSL0012	TSR0012
14"	TSL0014	TSR0014
16"	TSL0016	TSR0016
18"	TSL0018	TSR0018

- Steel shelf brackets suitable for Wall Struts.
- 5" high.

Wall Struts



Height	Item Number
18"	VWC0018
24"	VWC0024
30"	VWC0030
36"	VWC0036
42"	VWC0042
48"	VWC0048
60"	VWC0060
84"	VWC0084

- Struts are only suitable for Shelf Brackets for Wall Struts.
- 1-5/8" wide by 13/16" deep.

STEEL CASEWORK
MISCELLANEOUS ITEMS - SERVICE DROPS

Full Access Island Service Drops

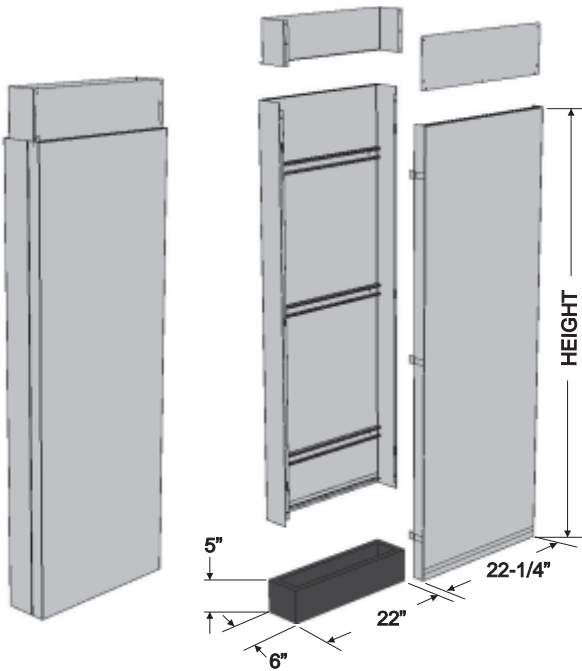

Height	Item Number
68"	SDP1368
73"	SDP1373
78"	SDP1378
90"	SDP1390

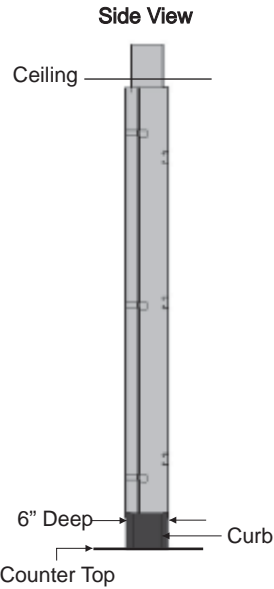

- Use to carry utilities from the counter top up through the ceiling.
- Service Drop offers full height (from counter top to ceiling) access to services.
- Front panel attaches with 'Z' clip.
- Designed to fit on a 22" wide x 5" high x 6" deep curb.

Full Access Wall Service Drops

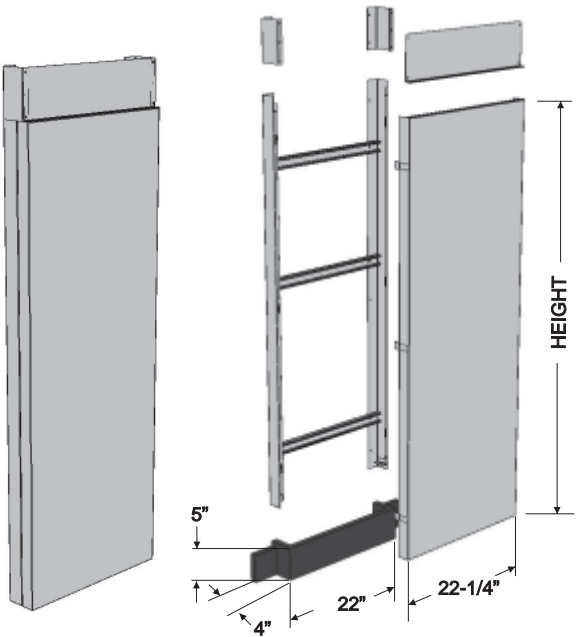

Height	Item Number
68"	SDP1468
73"	SDP1473
78"	SDP1478
90"	SDP1490

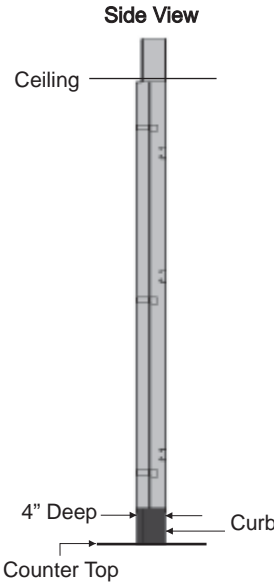

- Use to carry utilities from the counter top up through the ceiling.
- Service Drop offers full height (from counter top to ceiling) access to services.
- Front panel attaches with 'Z' clip.
- Designed to fit on a 22" wide x 5" high x 4" deep curb.

STEEL CASEWORK MISCELLANEOUS ITEMS - SERVICE DROPS

Service Drops

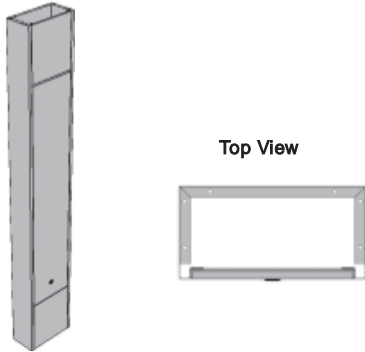

Height	6" Deep		8" Deep	
	12" Wide	24" Wide	12" Wide	24" Wide
78"	SDP3078	SDP4078	SDP1078	SDP2078
90"	SDP3090	SDP4090	SDP1090	SDP2090

- Use to carry utilities from the counter top up through the ceiling - for wall and island applications.
- Each assembly consists of two 12" high fixed upper and lower panels and a lift off center panel.
- 78" high service drop has 54" center lift off panel.
- 90" high service drop has 66" center lift off panel.

Radius Island Service Drops

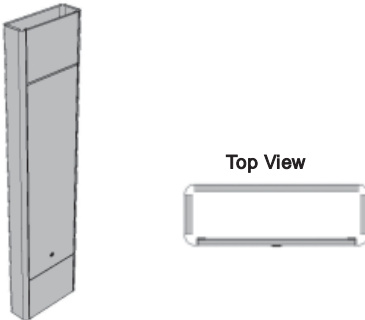

Height	12" Wide	24" Wide
78"	SDP1178	SDP2178
90"	SDP1190	SDP2190

- Use to carry utilities from the counter top up through the ceiling - for island applications.
- Each assembly consists of two 12" high fixed upper and lower panels and a lift off center panel.
- 78" high service drop has 54" center lift off panel.
- 90" high service drop has 66" center lift off panel.
- 6" deep (maximum depth available).

Radius Wall Service Drops

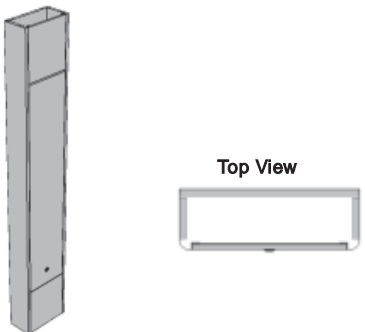

Height	12" Wide	24" Wide
78"	SDP1278	SDP2278
90"	SDP1290	SDP2290

- Use to carry utilities from the counter top up through the ceiling - for wall applications.
- Each assembly consists of two 12" high fixed upper and lower panels and a lift off center panel.
- 78" high service drop has 54" center lift off panel.
- 90" high service drop has 66" center lift off panel.
- 6" deep (maximum depth available).

Service Drop Ceiling Trims



Depth	12" Wide	24" Wide
6"	EDC1006	EDC2006
8"	EDC1000	EDC2000

- Not for use with Radius and Full access Service Drops.
- Required when service drop extends past the ceiling tile.
- Suitable for a 6" & 8" deep Service Drop.

STEEL CASEWORK MISCELLANEOUS ITEMS - LIGHT VALANCES

Light Valances



- Left side return light valance shown. Right side return light valance is opposite of what is shown.
- 3" high.

Width	Right Side Return		Left Side Return	
	12" Return	16" Return	12" Return	16" Return
18"	VPR3018	VPR4018	VPL3018	VPL4018
24"	VPR3024	VPR4024	VPL3024	VPL4024
30"	VPR3030	VPR4030	VPL3030	VPL4030
36"	VPR3036	VPR4036	VPL3036	VPL4036
42"	VPR3042	VPR4042	VPL3042	VPL4042
48"	VPR3048	VPR4048	VPL3048	VPL4048
60"	VPR3060	VPR4060	VPL3060	VPL4060
72"	VPR3072	VPR4072	VPL3072	VPL4072
96"	VPR3096	VPR4096	VPL3096	VPL4096



- Light valance to be fastened to the bottom of a wall cabinet. Available with left side, right side, or both returns.
- Use 12" deep light valance for 14" deep cabinets.
- Use 16" deep light valance for 18" deep cabinets.
- Light valance returns are 2" shorter in depth than the standard depth of the cabinet, to allow for clearance of opening and closing the doors above.
- 3" high.

Width	Right & Left Side Returns	
	12" Return	16" Return
18"	VPS3018	VPS4018
24"	VPS3024	VPS4024
30"	VPS3030	VPS4030
36"	VPS3036	VPS4036
42"	VPS3042	VPS4042
48"	VPS3048	VPS4048
60"	VPS3060	VPS4060
72"	VPS3072	VPS4072
96"	VPS3096	VPS4096



- Front only light valance to be fastened to the bottom of a wall cabinet.
- 3" high.

Width	Front Only
18"	VPF1018
24"	VPF1024
30"	VPF1030
36"	VPF1036
42"	VPF1042
48"	VPF1048
60"	VPF1060
72"	VPF1072
96"	VPF1096

Wall Cabinet Furring Panels



- Wall Cabinet Furring panels are used to close off the area between the top of a wall cabinet and the ceiling.
- Furring panels have a double scribe angle at top and a 2" wide flange at bottom.
- 24" high.

Width	End Panel		
	14" Deep	18" Deep	22" Deep
18"	FPS1018	FPS2018	FPS3018
24"	FPS1024	FPS2024	FPS3024
30"	FPS1030	FPS2030	FPS3030
36"	FPS1036	FPS2036	FPS3036
42"	FPS1042	FPS2042	FPS3042
48"	FPS1048	FPS2048	FPS3048
60"	FPS1060	FPS2060	FPS3060
72"	FPS1072	FPS2072	FPS3072
96"	FPS1096	FPS2096	FPS3096
1000mm	FPS100B	FPS200B	FPS300B

STEEL CASEWORK
MISCELLANEOUS ITEMS - TABLES

Stainless Steel Table Assemblies

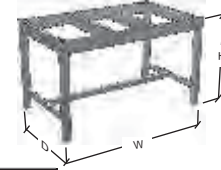
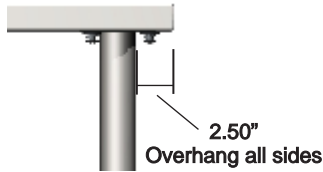

24" Overall Depth With Work Top		
Width	Sitting Hgt.	Standing Hgt.
24"	STA1024	STA2024
36"	STA1036	STA2036
48"	STA1048	STA2048
60"	STA1060	STA2060
72"	STA1072	STA2072
96"	STA1096	STA2096

30" Overall Depth With Work Top		
Width	Sitting Hgt.	Standing Hgt.
24"	STA3024	STA4024
36"	STA3036	STA4036
48"	STA3048	STA4048
60"	STA3060	STA4060
72"	STA3072	STA4072
96"	STA3096	STA4096

- Tables are 16 gauge, type 304 stainless steel work top, with a #4 finish.
- Tables have adjustable bottom shelf, cast aluminum corner brackets, and 1-5/8" stainless steel tubular adjustable bullet legs.
- Overall depth with work top is 24" or 30".
- Rated to hold 600 lbs evenly distributed.
- Tables 72" and larger are equipped with six legs.
- Shipped partially assembled.

Heavy Duty "O" Frame Tables



Width	22" Deep		28" Deep	
	Sitting Hgt.	Standing Hgt.	Sitting Hgt.	Standing Hgt.
24"	TDC2124	TDC1124	TDC2224	TDC1224
30"	TDC2130	TDC1130	TDC2230	TDC1230
36"	TDC2136	TDC1136	TDC2236	TDC1236
42"	TDC2142	TDC1142	TDC2242	TDC1242
48"	TDC2148	TDC1148	TDC2248	TDC1248
60"	TDC2160	TDC1160	TDC2260	TDC1260
72"	TDC2172	TDC1172	TDC2272	TDC1272
96"	TDC2196	TDC1196	TDC2296	TDC1296
1000mm	TDC210B	TDC110B	TDC220B	TDC120B
1500mm	TDC210C	TDC110C	TDC220C	TDC120C

- All legs and framing are 2" x 2" 14 gauge square steel tubing.
- Frame, cross-bracing and legs are welded in place. Tables larger than 48" wide are manufactured with six legs. Table legs are supplied with leveling glides.
- Tables are available in sitting height (28 3/4") and standing height (34 3/4").
- Table legs are supplied with leveling bolts and PVC boots.
- All tables will support an 1800 lb load.
- If adding casters load rating is reduced to 800lbs for 48" wide tables and 1200lbs for over 48" wide tables.
- Counter top not included.

Pencil Drawers



Width	Item Number
15"	PEN0015
18"	PEN0018
20"	PEN0020
24"	PEN0024
30"	PEN0030

- Pencil Drawer suspends from table, apron or Sigma Flex™ system with hanging rails.
- Drawer on Pencil Drawer is supplied with full extension runners.
- Order table or apron with option code HU to suspend Pencil Drawer.

**STEEL CASEWORK
MISCELLANEOUS ITEMS - TABLES 22" DEEP**

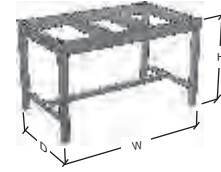

Standard "H" Frame Table

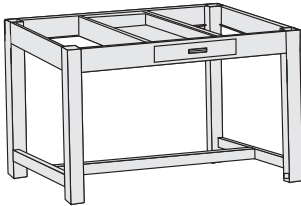

Width	Without Drawers		With Drawers		
	Sitting Hgt.	Standing Hgt.	# Drwrs	Sitting Hgt.	Standing Hgt.
24"	TAC2124	TAC1124	1	TAA2124	TAA1124
30"	TAC2130	TAC1130	1	TAA2130	TAA1130
36"	TAC2136	TAC1136	1	TAA2136	TAA1136
42"	TAC2142	TAC1142	1	TAA2142	TAA1142
48"	TAC2148	TAC1148	2	TAB2148	TAB1148
60"	TAC2160	TAC1160	2	TAB2160	TAB1160
72"	TAC2172	TAC1172	2	TAB2172	TAB1172
1000mm	TAC210B	TAC110B	1	TAA210B	TAA110B
1500mm	TAC210C	TAC110C	2	TAB210C	TAB110C

Six Leg Combination Table

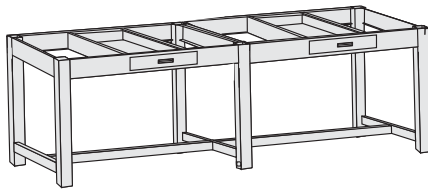

Width	Without Drawers		With Drawers		
	Sitting Hgt.	Standing Hgt.	# Drwrs	Sitting Hgt.	Standing Hgt.
72"	TCC2172	TCC1172	2	TCB2172	TCB1172
84"	TCC2184	TCC1184	2	TCB2184	TCB1184
96"	TCC2196	TCC1196	4	TCB2196	TCB1196
2000mm	TCC210D	TCC110D	2	TCB210D	TCB110D

MISCELLANEOUS ITEMS - TABLES 28" DEEP

Standard "H" Frame Table

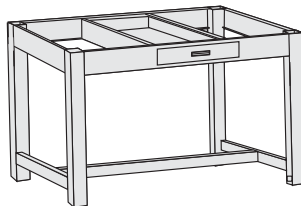

Width	Without Drawers		With Drawers		
	Sitting Hgt.	Standing Hgt.	# Drwrs	Sitting Hgt.	Standing Hgt.
24"	TAC2224	TAC1224	1	TAA2224	TAA1224
30"	TAC2230	TAC1230	1	TAA2230	TAA1230
36"	TAC2236	TAC1236	1	TAA2236	TAA1236
42"	TAC2242	TAC1242	1	TAA2242	TAA1242
48"	TAC2248	TAC1248	2	TAB2248	TAB1248
60"	TAC2260	TAC1260	2	TAB2260	TAB1260
72"	TAC2272	TAC1272	2	TAB2272	TAB1272
1000mm	TAC220B	TAC120B	1	TAA220B	TAA120B
1500mm	TAC220C	TAC120C	2	TAB220C	TAB120C

Six Leg Combination Table

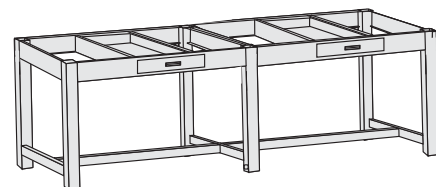

Width	Without Drawers		With Drawers		
	Sitting Hgt.	Standing Hgt.	# Drwrs	Sitting Hgt.	Standing Hgt.
72"	TCC2272	TCC1272	2	TCB2272	TCB1272
84"	TCC2284	TCC1284	2	TCB2284	TCB1284
96"	TCC2296	TCC1296	4	TCE2296	TCE1296
2000mm	TCC220D	TCC120D	2	TCE220D	TCE120D

STEEL CASEWORK OPTIONS

Ordering Special Features

Add Option	Description
-48	Keyboard tray (Replaces drawer)
-49	Adjustable height legs (see note)
-87	Mobile table complete with casters
-91	No lower frame (see notes)
-92	Table supplied with lower "U" frame
-93	Left Side Table Leg (No lower frame)
-94	Right Side Table Leg (No lower frame)
-95	Front Leg Table
-WA	Welded Table Assembly (see note 18 in "Options" section, page A16)
-HU	"U" frame table with floating rail to hang cabinets for TAC tables

- Tables shipped unassembled.
- All tables and sizes are supplied with lower H frames unless otherwise specified. All legs are 2"x2"x16ga steel tubing. All lower frames are 1"x2" x 16ga steel tubing. All legs are bolted in place.
- Table legs are supplied with leveling bolts and PVC boots.
- Tables are available in sitting height (28 3/4") and standing height (34 3/4").
- Available with 1 or 2 drawers, (except tables that include hanging cabinets).
- All tables are supplied with a lower H or U frame, and will support a 600lb load evenly distributed.
- Tables may be supplied without a lower H or U frame if the table width is 48" or less, and/or the required load is 200lbs or less. All tables may be supplied without a lower H or U frame and support a 600lb load if all legs are bolted securely to the floor. (ie: seismic design).
- Standard apron height is 3 3/4"H
- Drawer width is 15" w unless otherwise specified.
- Mobile tables of all sizes are supplied with a lower H frame, excluding mobile tables that accommodate hanging cabinets. A mobile table manufactured to accommodate hanging cabinets is specified with both options -87 (*Mobile table complete with casters*) and -HU (*U frame table with floating rail to hang cabinets*).
- 22" deep tables will only accommodate 18" deep hanging cabinets. 28" deep tables will accommodate 18" or 22" deep hanging cabinets. All tables manufactured to accommodate hanging cabinets have a lower U frame. All tables 72" and wider that are manufactured to accommodate hanging cabinets have heavy duty upper aprons.
- Option -49, shall be used only with sitting height tables, legs are adjustable in 1" increments, from 28-3/4" high to 34-3/4" high (worktop not included).
- Option -HU is not feasible in drawer models.
- Special table and Hanging Cabinet height is required when using -HU and -06 option.
- Option codes "06" Table shelf and "HU" "U" frame table with floating rail to hang cabinets for TAC tables cannot be used together.

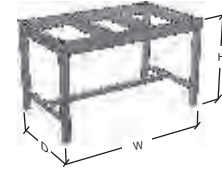

STEEL CASEWORK MISCELLANEOUS ITEMS - TABLES

Crank-Operated Table Frames



Note: 23" Deep table shown.

Table Frame Width	Adjustable From 25"-33" (8" of travel)		Adjustable From 29"-41" (12" of travel)	
	23" Deep	29" Deep	23" Deep	29" Deep
36"	ACT2036	ACT2136	ACT1036	ACT1136
48"	ACT2048	ACT2148	ACT1048	ACT1148
60"	ACT2060	ACT2160	ACT1060	ACT1160

- Place adjacent to any Sigma Flex™ structure or wall. Use in any setting as a self-supporting work station.
- Tables are not suitable for hanging cabinets.
- Table complete with integral modesty panel and table legs are supplied with leveling glides.
- Crank-operated height adjustability from 25" to 33" or 29" to 41" .
- All tables will support a 300 lb load.
- Table frame only, work surface not included.

Adjustable Height Science Tables



Work Surface Size	Item Number
48" x 36"	SCT0148
60" x 36"	SCT0160
72" x 36"	SCT0172
96" x 36"	SCT0196

- Hand crank height adjustment from 30" to 40" allows multiple uses.
- Dimensions may be adjusted to suit customer requirements.
- Load bearing capacity of 500lbs (including work surface).
- Work surface not included.
- The unit comes with 3 electrical cutouts and cover plates.
- If you require receptacles/wiring please contact Mott for pricing.
- Available Options:
 - EM (Integral Electric for height adjustment)
 - CD (Provision for height adjustment by Cordless Power Drill)
 - CU (CPU holder below work surface of table)
 - BH (Hooks for book bags below work surface)

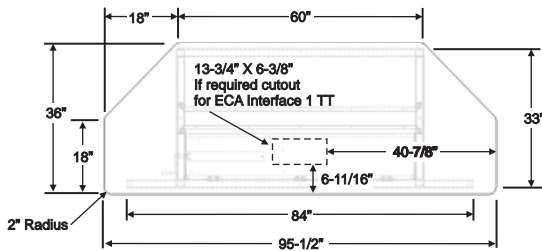

Typical Adjustable Height Science Table Work Surface

- Recommended work surface is as shown - notched to allow multiple tables to fit together.
- Drawing shown for 96" wide unit.

Hanging CPU Holder



Item Number
CPU1010

- Suspends from table, apron or Sigma Flex™ system with hanging rails and is supplied with full extension runners to slide out CPU unit.
- Inside clear dimension of CPU holder is 9-3/16".
- Hanging CPU Holder does not fit on a 22" deep table.
- Order table or apron with option code HU to suspend CPU holder.

STEEL CASEWORK
MISCELLANEOUS ITEMS - TABLES

Vibration Isolation Tables



Width	22" Deep		28" Deep	
	Sitting Hgt.	Standing Hgt.	Sitting Hgt.	Standing Hgt.
36"	VIT2136	VIT1136	VIT2236	VIT1236
42"	VIT2142	VIT1142	VIT2242	VIT1242
48"	VIT2148	VIT1148	VIT2248	VIT1248

The Vibration Isolation Table is designed to provide stable working conditions for devices that are sensitive to vibration and shocks. Table consists of an outer table frame that supports the main work surface which is not isolated from vibration and an inner table frame that is entirely separate and supports the inner isolated work surface. This ensures vibrations are not transmitted to the isolated inner work surface.

- **Outer Table Frame** consists of two 18 gauge hollow vertical pedestals. Each pedestal has removable inner panels for access the anchor bolts and levelers. Pedestals are connected with 16 gauge steel rails. A flange is provided around the perimeter of the pedestals for mounting of the non-isolated work surface.
- **Inner Table Frame** consists of a rectangular hollow steel welded frame with each leg supplied with levelers and provisions for anchoring. Legs are joined by 11 gauge steel angles which support the isolated platform.
- **Isolated Platform** consists of a formed 18 gauge steel tray that is to be filled with ballast (such as sand or concrete - not included). The platform is supported by four rubber shock absorbing isolators. A flange is provided around the perimeter of the tray for mounting the isolated work surface.
- Available in either type 304 stainless steel or powder coated steel.
- Work surface not included.
- Shipped assembled and skidded.

Top of Table View

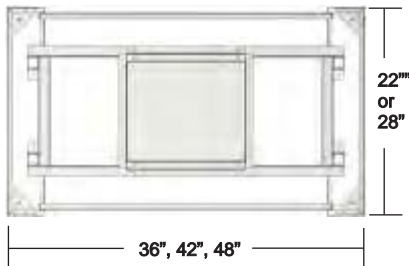

Front View

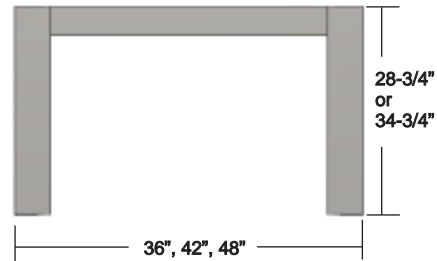

Typical Non-Isolated 1" Thick Work Surface
For 22" and 29" Deep Tables

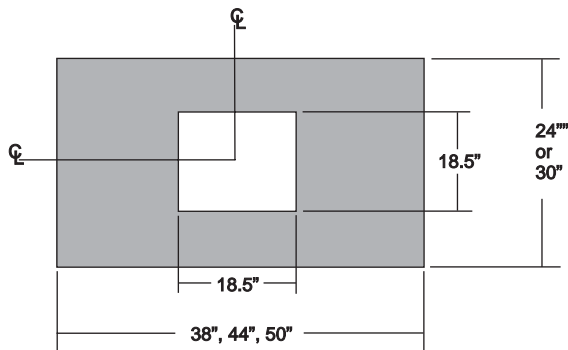

Typical Inner Isolated 1" Thick Work Surface
For 22" and 29" Deep Tables

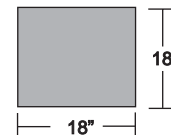

- Work surface shown with 1" overhang on all sides for freestanding installations.
- When in an elevation of casework, adjust overhang as needed.

STEEL CASEWORK
MISCELLANEOUS ITEMS - Cylinder Storage Rack

Cylinder Storage Rack



Item Number
CSR1000

- Holds up to 10" diameter cylinders.
- Capable of handling up to 2 full size cylinders.
- Welded steel rack 30"H x 30"W x 16"D
- Secure to walls and floor with 1/2" steel anchor bolts.
- Non-kink zinc plated chain.



Item Number
CSR2000

- Holds up to 10" diameter cylinders.
- Capable of handling up to 4 full size cylinders.
- Welded steel rack 30"H x 30"W x 26"D
- Secure to walls and floor with 1/2" steel anchor bolts.
- Non-kink zinc plated chain.



Item Number
CSR3000

- Holds up to 10" diameter cylinders.
- Capable of handling up to 4 full size cylinders.
- Welded steel rack 30"H x 30"W x 38"D
- Secure to walls and floor with 1/2" steel anchor bolts.
- Non-kink zinc plated chain.

STEEL CASEWORK
MISCELLANEOUS ITEMS - REAGENT ISLAND SHELVING UNIT

Reagent Island Shelving Unit

Reagent Island Shelving Units are designed to provide support for shelving and are 1" wide by 2" deep. Units are available in custom lengths to suit your exact requirements.



Reagent Island Shelving Unit



- Contact Mott regarding load rating.

STEEL CASEWORK
MISCELLANEOUS ITEMS - REAGENT ISLAND SHELVING UNIT

Reagent Uprights



NUMBER OF BAYS	Item Number
2 Bay	RIU0002
3 Bay	RIU0003
4 Bay	RIU0004



- Used for island assemblies where upright shelving is needed and relies on adjacent fixed casework for support.
- Available in custom lengths to suit your requirements. Please contact Mott for ordering details. When ordering Reagent Upright units, please provide overall length and bay opening dimensions.
- Reagent Uprights are 90" high by 1" wide by 2" deep tubing and are supplied with base supports.
- Uprights are double slotted on both sides allowing shelving to be adjustable in 1" increments.
- Reagent Uprights are only suitable with "SBP" Shelf Brackets located on page G13.
- Shelves can be ordered in powder coated steel and wood. Please contact Mott for ordering details.
- Reagent Uprights are not suitable for suspending cabinets or work surfaces.
- Maximum length available without a seam in upper rail is 120" long.



Reagent Upright Shelving



- Reagent Uprights are only suitable with "SBP" Shelf Brackets located on page G13.
- Shelves can be ordered in powder coated steel and wood. Rear shelf angles are recommended. Please contact Mott for ordering details.