



Claridge®



newenglandlab®
laboratory furniture systems

888.635.2080 | newenglandlab.com



NEW CONSTRUCTION & RENOVATION

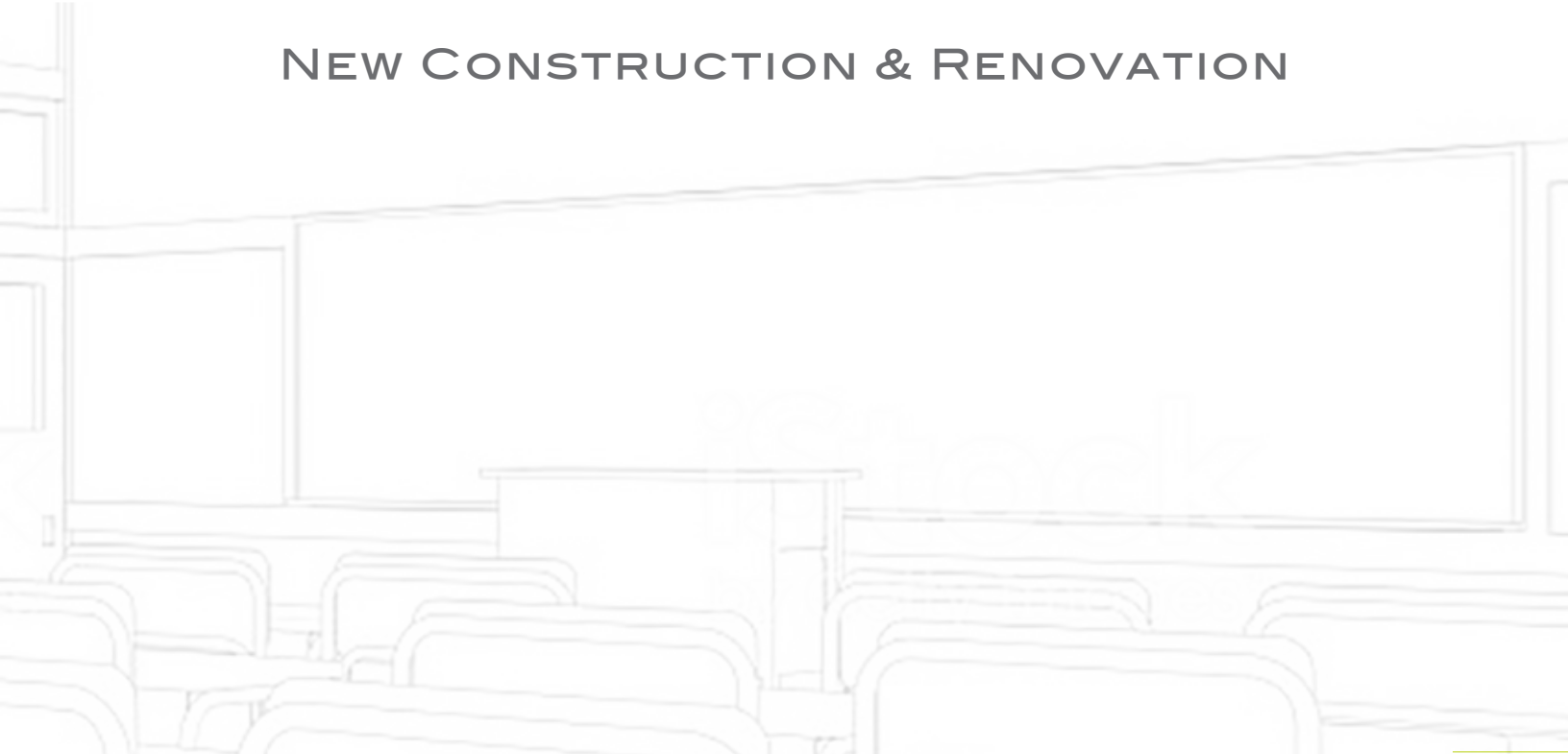

2020 CATALOG



**FOR OVER 70 YEARS,
THE CLARIDGE
NAME HAS BEEN
SYNONYMOUS WITH
QUALITY, SERVICE
AND INNOVATION.**

Our products can be found in gleaming new offices, prestigious colleges and universities, respected hospitals and schools across the country. Claridge offers a complete set of solutions for the new world of work – no matter what type of work you do.

From the workplace to the classroom, the emphasis today is on performance, productivity, and a pleasing environment. Claridge visual display products and accessories offer unmatched performance and high style. A state-of-the-art production facility enables our skilled team to control quality at every step in the process. In addition to offering a broad selection of standard colors, surfaces and finishes, we can custom-craft most products to perfectly suit any space or task. Let our friendly and knowledgeable customer service staff help you create exactly what you need.

Contemporary business operates at a lightning pace, so we maintain a wide variety of standard product lines in stock for fast shipping and delivery. For custom product orders, Claridge Priority Response and On-Time Shipping provide a firm ship date.

We also conduct a number of “green” initiatives—from in-house recycling programs to using renewable resources and alternative materials—to reduce our environmental footprint and minimize exposure to harmful substances. We listen and react to our customers’ needs and concerns.

At Claridge, we work to earn your trust and satisfaction from start to finish. That’s the way we do business — today and always.

TABLE OF CONTENTS

4	Markerboards, Chalkboards and Tackboards - Series 1, 3, 4, 5, 8, 185	9	Vertical Sliding Systems
6	Aluminum trim detail applications	10	Marker Walls
7	Glass Markerboards	11	Tack Walls
7	Contemporary Lecture Cabinets	12	Bulletin Board Cabinets
8	Horizontal Sliding systems	13	Display Cases
		15	Specification Information

THE WRITING SURFACE EXPERTS™

Claridge LCS³ Porcelain™ and Claridge Glass are the global choice for visual display writing surfaces. These incredibly smooth and clean performing writing surfaces provide a great writing experience that will stand the test of time.

LCS³ Porcelain Markerboards

- Porcelain enamel steel markerboards provide a sustainable, ultra-smooth and lifetime warranted surface that is scratch, stain and bacteria resistant
- Available in three colors, LCS³ can be used as a projection surface; accepts magnetic aids
- Specially formulated porcelain surface is fused to enameling grade steel in accordance with Performance Specifications established by the Porcelain Enamel Institute
- The resulting porcelain surface is GREENGUARD™, Cradle-to-Cradle™ and SCS Indoor Advantage™ certified

Markerboards are guaranteed to withstand the rigors of everyday use and offer superior writeability, eraseability and interactive performance.

Porcelain Chalkboard Surfaces

- Porcelain enamel steel chalkboard surface carries a Life of the Building writing surface warranty; available in three colors
- Writing surface has high resistance to impact damage, abrasion, scratching and fading
- Matte finish provides maximum contrast for heightened visibility; surface erases clean and retains minimal chalk dust

Porcelain chalkboards provide a super smooth writing surface that erases like magic and will not scratch, stain or fade.

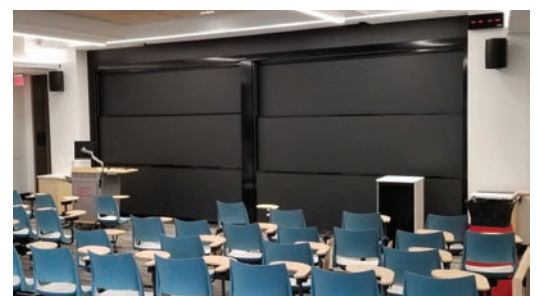
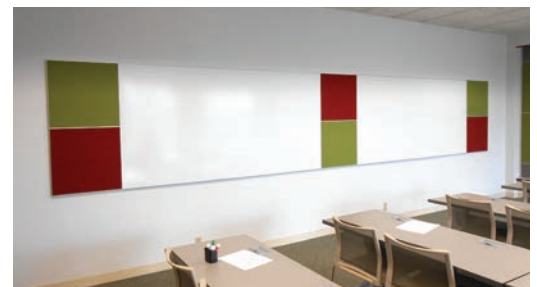

Series 1



- Perimeter trim is 1 1/2" wide.
- Type A units have screw through map rail at top; angle clips for bottom.
- Type CO and Combos – angle clips 2' on center top and bottom

Series 3

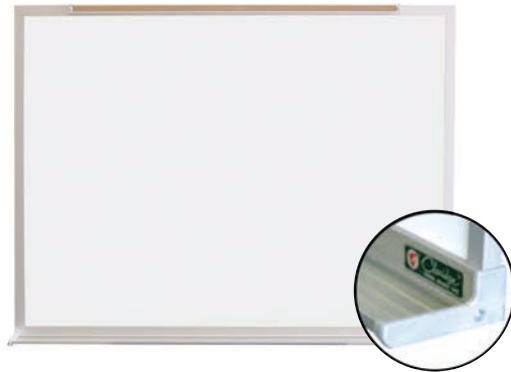

- Perimeter trim is 1-1/4" wide.
- Type A units have screw-through map rail at top; angle clips for bottom.
- Type CO and Combos – angle clips, 2' on center, top and bottom.

Series 4



- Perimeter trim is 5/8" wide.
- Type A units have screw-through map rail at top; angle clips for bottom.
- Type CO and Combos – angle clips, 2' on center, top and bottom.

Series 5

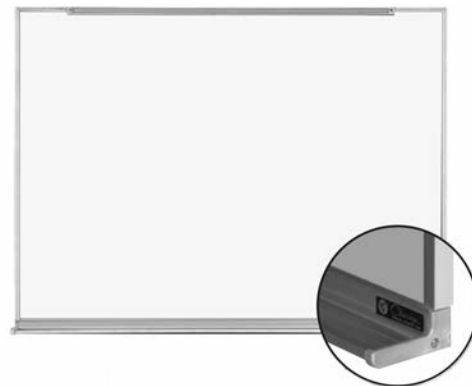

- Perimeter trim is 5/8" wide.
- Furnished with steel mounting clips at top and angle clips at bottom, 2' on center.

Features:

- Porcelain enamel steel markerboards and chalkboards
- Claridge Cork, Fabricork, Designer Fabric, Hook-Fab, and Tan Nucork Tackboards
- Satin anodize aluminum frame
- Maximum length, 16'0"; maximum height - Type A and Type CO units - 4'0"
- O.A. panel thickness approx. 1/2"
- LCS3 Markerboards are GREENGUARD Certified

Options:

- Color anodize or powder coat finish aluminum frames
- Radius corners available, Series 4 units

Finished size of units is 1/4" larger in height and width than sizes listed. If exact overall size is required, specify when ordering. Installation using 16A adhesive is recommended. Screws or wall anchors are not included. Freight class 70.

Visit claridgeproducts.com for CAD library and specifications.

Series 8

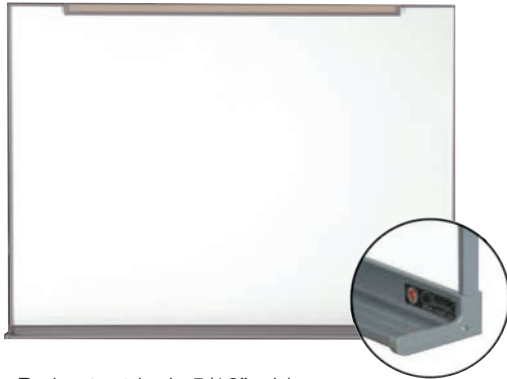

- Perimeter trim is 5/16" wide.
- Type A units have screw-through map rail at top; angle clips for bottom.
- Type CO and Combos – angle clips, 2' on center, top and bottom.

Series 185



- Perimeter trim is 1-1/2" wide.
- Furnished with Z-bar clips for top and angle clips for bottom, 2' on center.
- Note:** Necessary 12" square, 1/2" Duracore blocking pads are furnished.

WRITING SURFACES:

LCS ³	<p>LCS³</p> <ul style="list-style-type: none"> · Porcelain enamel steel · Smooth, dry-erase porcelain surface for easy writing and clean erasing · Porcelain surface can be used for projection
MLC	<p>MLC</p> <ul style="list-style-type: none"> · Synthetic dry-erase surface applied to hardboard · Economical, non-magnetic, white melamine writing surface
NP ³	<p>NP³ Chalkboard</p> <ul style="list-style-type: none"> · Porcelain enamel steel · Smooth surface insures unsurpassed chalking and erasing qualities
Glass	<p>Magnetic Glass</p> <ul style="list-style-type: none"> · 1/4" tempered glass · Silky smooth surface writes easily, erases cleanly · Virtually maintenance free

MARKERBOARDS: COLOR OPTIONS

100 White LCS ³	101 Light Gray LCS ³	102 Beige LCS ³	1032 MLC White Melamine
-------------------------------	------------------------------------	-------------------------------	----------------------------

NP³ CHALKBOARDS: COLOR OPTIONS

500 Green	501 Black	502 Gray
-----------	-----------	----------

TACK SURFACES:

Claridge Cork, Tan Nucork, Fabricork, and Designer Fabric
See claridgeproducts.com

Common Markerboard Chalkboard & Tackboard Arrangements

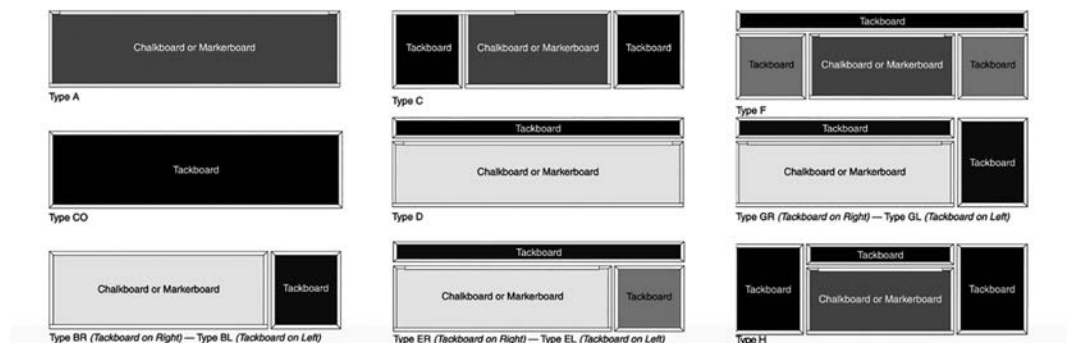

Snap-On Aluminum Trim Detail

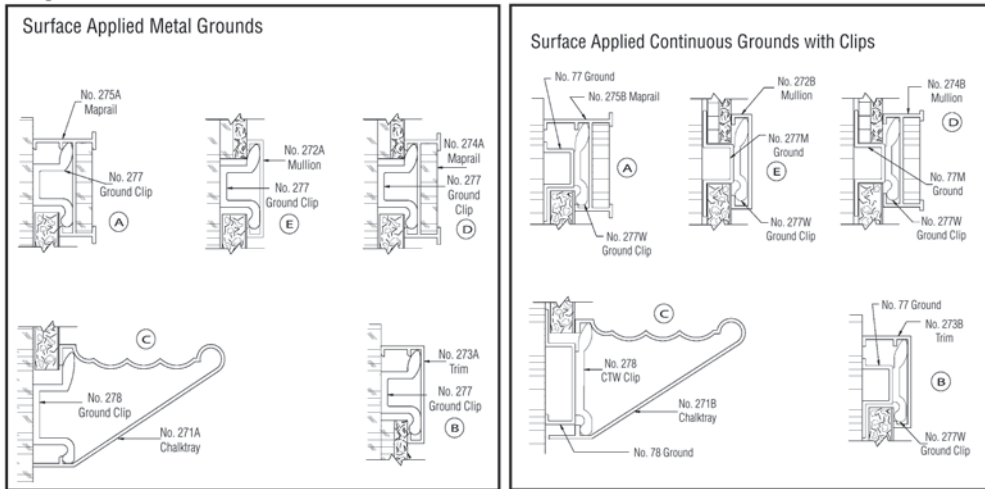

The most versatile of the field assembled trims, snap-on trim, with its wide face and no visible fasteners, adjusts to job conditions and joins in a neat, precision fit.

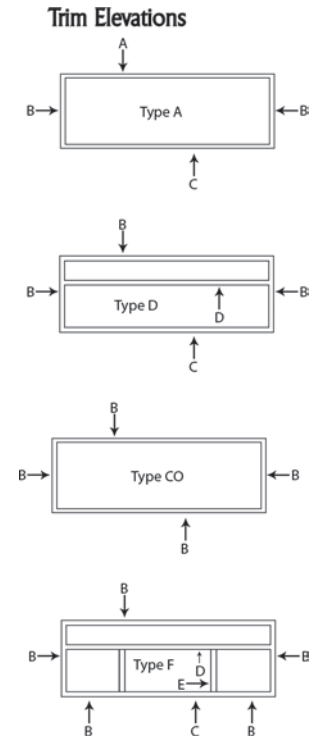

Screw-On Aluminum Trim Detail

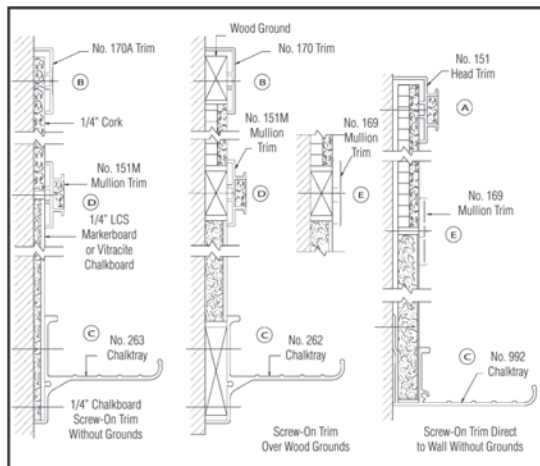

Screw-on aluminum trim, with exposed fasteners, is noted for ease of installation

Slip-On Aluminum Trim Detail

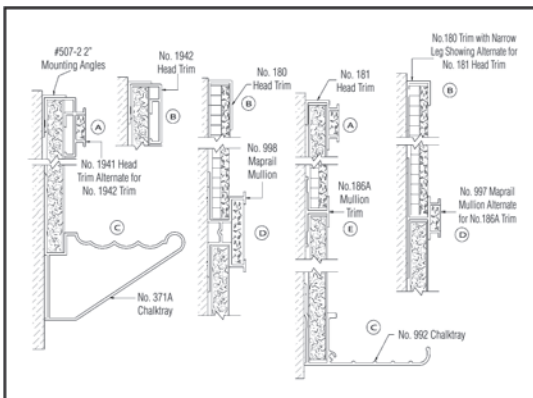

The narrow face of slip-on trim gives it a clean, low-profile appearance.

Divider Bars, Channel Trim & Angle Trim

DIVIDER BARS

Number	Opening	Face	Stock Lengths
803	1/4"	1/2"	12'6"
803A	1/2"	1/2"	12'6"
803F	1/2"	1"	12'6"

Divider bars weigh approximately 1/4 lb. per lin. ft. Shipped by motor freight. Use freight class 85.

CHANNEL TRIM

Number	Opening	Face	Stock Lengths
804	1/4"	1/2"	17'
1067	1/2"	5/8"	12'6" and 17'

Channel trim weighs approximately 1/4 lb. per lin. ft. 8' and 8'6" lengths can ship UPS or Fed Ex Ground. Balance of lengths will be shipped motor freight. Use freight class 85.

ANGLE TRIM

Number	Description	Stock Lengths
803	1" x 1" x 1/16" angle trim	12'6"
803A	1" x 1/2" x 1/6" angle trim	12'6"
803F	1" x 1" x 1/8" angle trim	12'6"

No. 160 and No. 161 angle trim weights approx. 1/4 lb. per lin. ft. No 162 weighs 1/3 lb. Angle trim is shipped by motor freight. Use freight class 85.

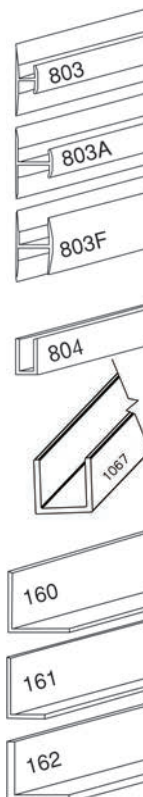

Magnetic Glass Markerboards

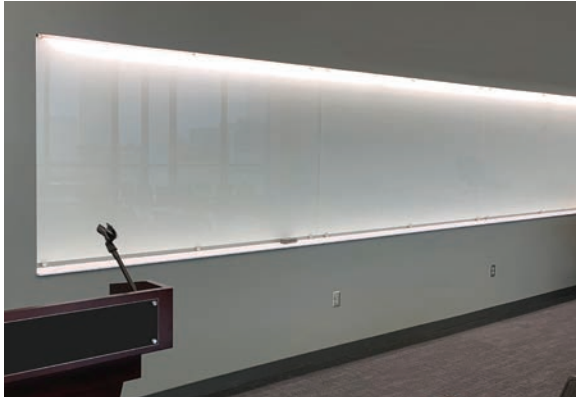

Features:

- 1/4" tempered low-iron glass dry-erase writing surface with steel back
- Eased corners and polished edges
- Furnished with 4 rare earth magnets
- Choose brushed stainless edge grips for easy and attractive stand-off mounting (4 per board on sizes through 4x4; 4x6 & 4x8 have 6) or invis-mount – no visible hardware
- Furnished in brilliant white if no color specified. 10 standard colors, 180 optional colors.

Mounting Options:

- MGM glass markerboards include brushed stainless edge grips for stand-off mount
- MGMI glass markerboards have invis-mount with no visible hardware for a "floating" appearance

Options:

- 4 Rare Earth Magnets
- Accessory tray, markers and microfiber cloth are optional*



Stand-Off Mount



Invisi-Mount

Contemporary Lecture Cabinets



Features:

- Radius corners (except 518's); square corners optional
- White LCS³ low gloss porcelain enamel writing surface
- 1691 Quartz Designer Fabric bulletin board inside doors (other fabrics and colors optional)
- Concealed hangers for easy and secure installation
- Lecture units 3-3/4" deep

Accessories:

- 1 white sketching pad
- 4 LCS markers and 1 eraser
- Display Rail with cork insert
- Spring clip hooks for charts

Options:

- Matte White projection screen
- Light
- LCS inside doors in lieu of bulletin board
- Laminate lecture units with square corners
- Lock and Keys

Number	Size	Wood and Finish
509-4N	4' x 4'	Oak Natural
509-4M	4' x 4'	Oak Medium
509-6N	4' x 6'	Oak Natural
509-6M	4" x 6"	Oak Medium
512-4MS	4" x 4"	Mahogany
512-6MS	4' x 6'	Mahogany
516-4MA	4' x 4'	Maple
516-5MA	4' x 6'	Maple
517-4CH	4' x 4'	Cherry
517-6CH	4' x 6'	Cherry
518-4PL	4' x 4'	Laminate
518-6PL	4' x 6'	Laminate

Wood Finishes

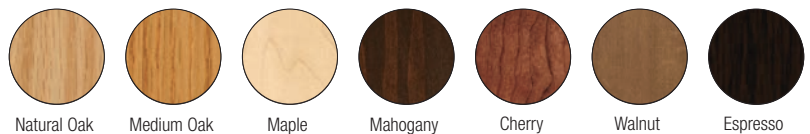

Wood finish color samples are reproduced with reasonable accuracy. If match is critical call 800-434-4610 for actual sample. Custom match finishes optional.

HORIZONTAL SLIDING UNITS



Horizontal Sliding Units are custom-built to meet custom needs, providing optimum display surfaces within easy reach for teaching, conferences and training.

Features:

- Heavy-duty aluminum housing with satin anodize finish
- Sliding panels are top-suspended and glide easily over aluminum track on molded nylon rollers
- Nylon ball bearing rollers at top of unit and nylon guide rollers at bottom eliminate vibration and provide smooth, quiet operation
- Fixed back panel with 2, 3 or 4 sliding panels on 2, 3, or 4 tracks, offered in sizes up to 4' x 24'
- Sliding panels and back panel can be LCS markerboard or porcelain chalkboard, or Claridge Cork, Fabriccork, Designer Fabric or Tan Nucork tackboard, Projection screen, or COM fabrics
- Component parts (sliding panels with track, guide channel, and hardware, but no housing) available

Number	Size (H x W)
HS46	4' x 6'
HS48	4' x 8'
HS410	4' x 10'
HS412	4" x 12"
HS414	4" x 14"
HS416	4' x 16'
HS420	4' x 20'
HS424	4' x 24'

2-track units weigh approx. 6 1/2 lbs. per sq. ft.
4-track units weigh 11 1/2 lbs. per sq. ft.

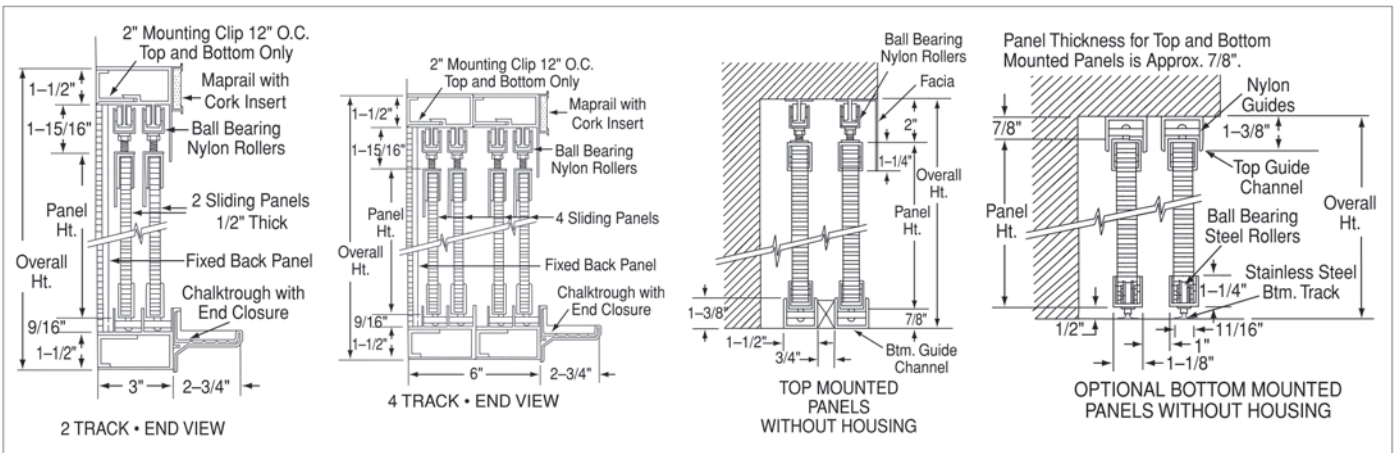

VERTICAL SLIDING UNITS

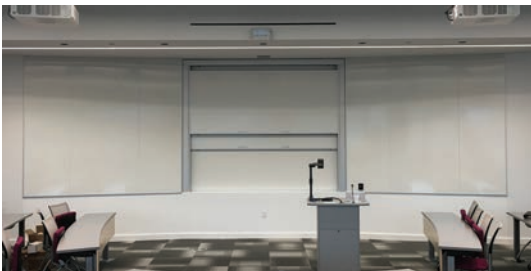

Vertical Sliding Units offer ideal visual communication solutions where large visual display surfaces are required but space is limited.

Features:

- Heavy-duty aluminum housing, trim and panel edging are extruded aluminum with satin anodize finish
- Manually or Motor Operated Units
- Floor and wall mounted (panels on wall mounted units slide from sill or tray to top of unit; panels on floor mounted units slide from floor to top of unit)
- Balanced, lightweight panel construction provides needed rigidity and eliminates to and fro movement when panels are in use
- One, two or three 7/8" thick sliding panels (2-panel housing is 6-1/2" deep; face is 4")
- Back panel and sliding panels can be LCS markerboard or porcelain chalkboard, or Claridge Cork, Fabricork, Designer Fabric or Tan Nucork tackboard, Projection screen, or COM fabrics

Manually Operated Floor Mounted		Manually Operated Wall Mounted		Motor Operated Floor Mounted	
Number	Size (H x W)	Number	Size (H x W)	Number	Size (H x W)
410CS	10' x 4'	48CSW	8' x 4'	410MO	10' x 4'
510CS	10' x 5'	58CSW	8' x 5'	510MO	10' x 5'
610CS	10' x 6'	68CSW	8' x 6'	610MO	10' x 6'
810CS	10' x 8'	88CSW	8' x 8'	810MO	10' x 8'
1010CS	10' x 10'	108CSW	8' x 10'	1010MO	10' x 10'
1210CS	10' x 12'	128CSW	8' x 12'	1210MO	10' x 12'
1410CS	10' x 14'	148CSW	8' x 14'	1410MO	10' x 14'
1610CS	10' x 16'	168CSW	8' x 16'	1610MO	10' x 16'

Optional Kick Panel and optional Wireless remote control. Approved shop drawings required. Freight class 70.

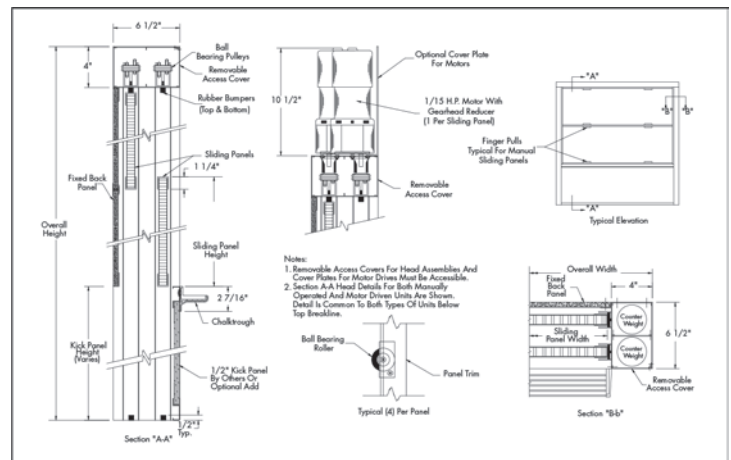

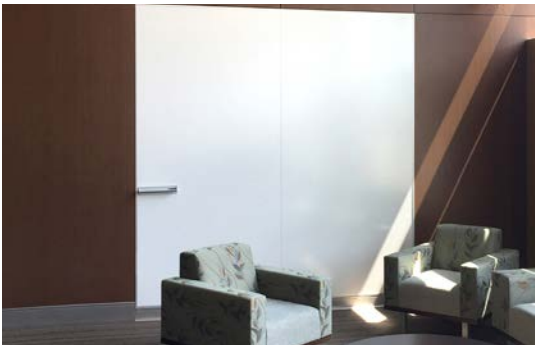

Marker Walls offer a room-size presentation surface designed for heavy use and multiple-format presentations.

Features:

- Cover an entire wall, floor-to-ceiling
- Utilize all available space
- Panels butt together for a continuous writing surface
- Low-gloss surface can be used for projection

When laminated panels are required, LCS, mounted on 7/16" MDF, has matched joints and can be joined with steel spline joints for smooth alignment. For a more finished look use No. 1016 perimeter trim.

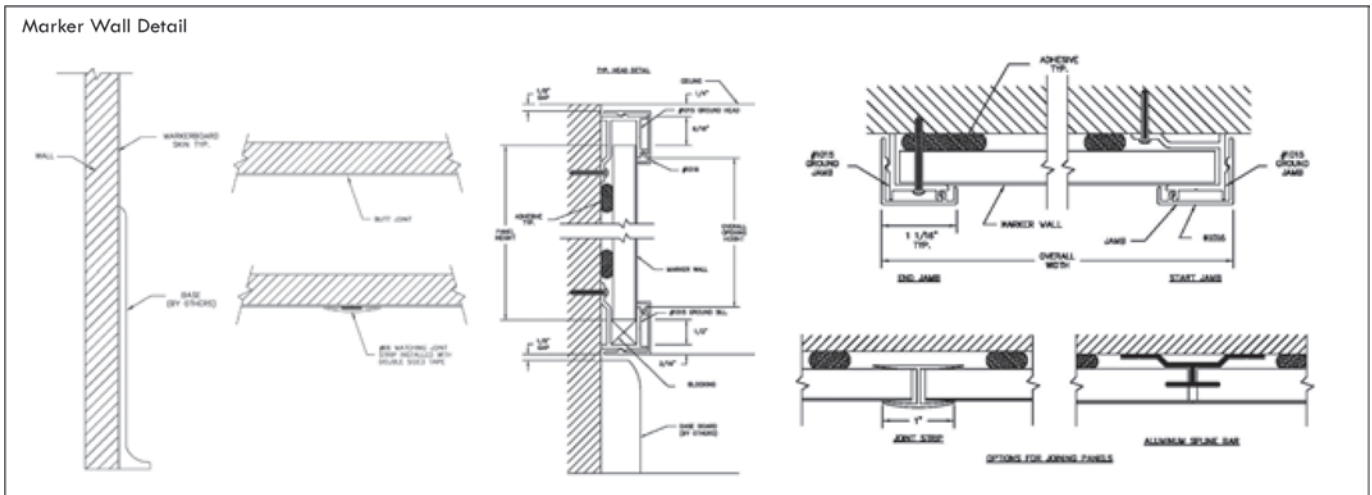

TACK WALLS



Edge-wrapped panels of either Fabricork or Designer Fabric butt together to cover an entire wall or work space, floor-to-ceiling.

Features:

- Choose from Fabricork and Designer Fabric colors
- Ideal for offices, board rooms, conference rooms, etc.
- Edge-wrapped panels can be custommade to fit existing walls

Where trim is required, fabric covered H-bars, fabric covered trim and fabric covered inside and outside corners are also available.

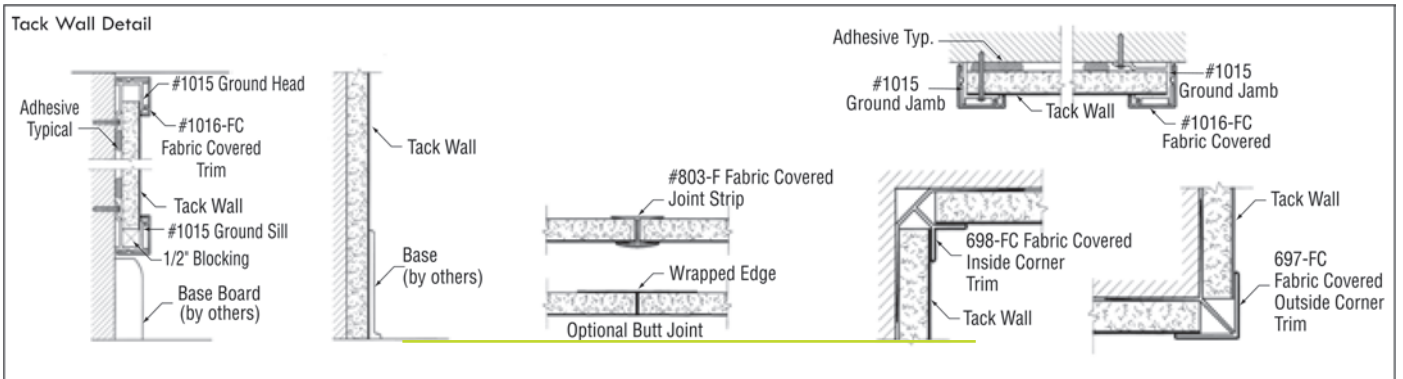

Claridge Cork

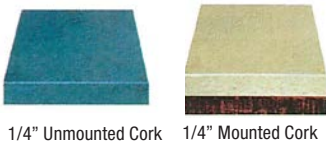

Claridge Cork is environmentally friendly, burlap backed cork made from pure natural ingredients. Smooth, durable suede-like surface is soil resistant and dimensionally stable; tacks insert easily and are gripped firmly.

Fabricork

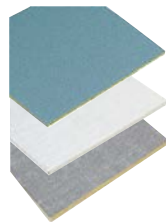

Fabricork, in 4 distinct patterns – Viewpoint, Esquire, Linden, and Belair, is available in a wide range of colors. Superior in style and performance, Fabricork is long-lasting and easy to clean.

Designer Series

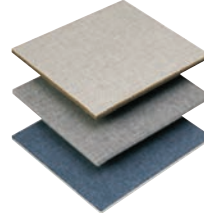

Designer Series fabrics (Guilford® FR701 pattern) provide tack surfaces with classic appeal, ideal in any environment. Durable, easy to clean, and sustainable, Designer Series fabrics are made from 100% recycled polyester.

Tan Nucork



Tan Nucork is a premium grade, fine grain natural tan composition cork. Nucork is dimensionally stable and has uniform density and particle size.

Contemporary Series Bulletin Board Cabinet

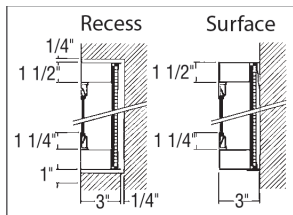

Features:

- 1-1/2" x 3" rectangular aluminum perimeter trim, satin anodize finish; inside depth 1-3/4"
- Tackable back panels can be Claridge cork, Fabricork, Designer Fabric, Hook-Fab or Tan Nucork (grooved directory back panels optional)
- 3/16" tempered glass doors with flat key tumbler locks
- Hinged door cabinets have continuous piano hinges; sliding door units, ground-in finger pulls
- Surface mounted units equipped with Z-bar hangers
- Available with header panel

Options:

- Light
- Weatherproofing (hinged door only)
- Recessed installation
- Medium or dark bronze anodize or powder coat finish

Number	Size (H x W)	Weight lbs.
2035	3' x 2'	42
2041	3' x 4'	72
2040	4' x 4'	96
2044	4' x 6'	144
2046	4' x 8'	256
2048	4' x 10'	320
2050	4' x 12'	384

Note: 3' x 2' cabinet has one door; 3' x 4' through 4' x 6' have two; and 4' x 8' through 4' x 12' have three.

Large Contemporary Series Bulletin Board Cabinet

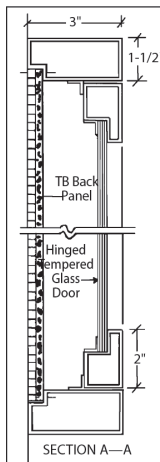

Features:

- Heavy-gauge rectangular aluminum, satin anodize finish
- Tempered glass doors hung on piano hinges, flat key tumbler locks
- Mitered corners reinforced for rigidity
- Tackable back panels in Claridge Cork, Fabricork, Hook-Fab, Designer Fabric or Tan Nucork
- Angle hangers furnished - top and bottom
- 3" housing - 1-3/4" I.D.; 4" - 2-3/4" I.D.

Options:

- 1-1/2" x 3" or 1-3/4" x 4" housing
- Surface or Recess installation
- Light (4" cabinets only)
- Med. or Dk. Bronze Anodize; Powder Coat Finish

Number	Size (H x W)	Weight lbs.
2153	5' x 3'	180
2156	5' x 6'	300
2164	6' x 4'	250
2168	6' x 8'	500

Note: Note: 3' and 4' widths have one door; 6' and 8' cabinets have two. Specify depth - 3" or 4", recess or surface installation (if recess installation, provide finished opening measurements), and type and color for back panel.

Imperial Series Bulletin & Directory Board Cabinet



Features:

- 3/16" tempered sliding glass doors; tumbler lock
- 3 1/4" O.A.; inside depth 1 1/2"
- 6" translucent plexiglass header panel

Header	No Header	Size (H x W)	Weight lbs.
300	294	36" x 48"	80
302	296	36" x 72"	120
303	297	48" x 60"	135
304	298	48" x 72"	160

No.310 Bulletin Board Cabinet



Features:

- 3 1/4" perimeter; inside depth 1 1/4"
- Sliding glass door shoe, channel and track are heavy-gauge extruded aluminum, bronze finish

Number	Size (H x W)	Weight lbs.
310	36" x 48"	78
310A	36" x 60"	98
310B	36" x 72"	118
310C	48" x 60"	130
310D	48" x 72"	156