

ALTUS™ TABLE SYSTEM

ADAPTABLE LABORATORY FURNITURE SOLUTIONS

Altus™ Table System

The Altus™ table system is designed to adapt to an array of laboratory processes, equipment and users. It conveniently supplies all the services and features required for today's laboratory in a self-contained and self-standing bench assembly. This stylish system is available in powder coated steel finish or stainless steel.

With Altus™, laboratories can be easily created, changed and reconfigured for new applications or changing space. Integrated services deliver quick and easy access while providing superior flexibility by keeping the work surface open. Plumbing and electrical services are factory installed and designed to quick connect to ceiling mounted service panels or overhead service carriers.



For additional information and help in planning contact Mott Manufacturing.

ALTUS™ TABLE SYSTEM

CIRCUIT DETAILS

Circuit Details

Standard Wiring

1 Circuit

48", 60", 72" Wide Assembly

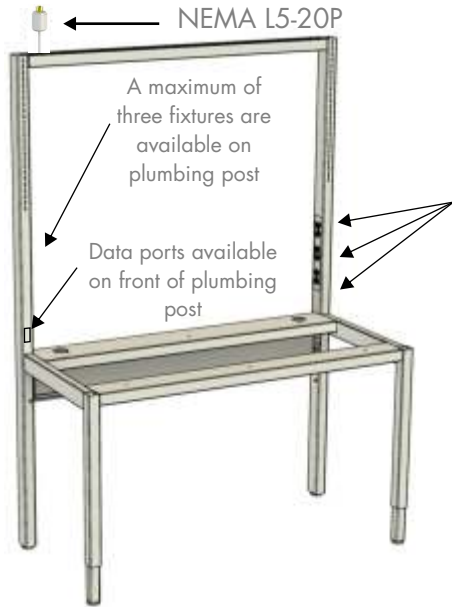

Circuit 1
Three duplex receptacles on electrical post

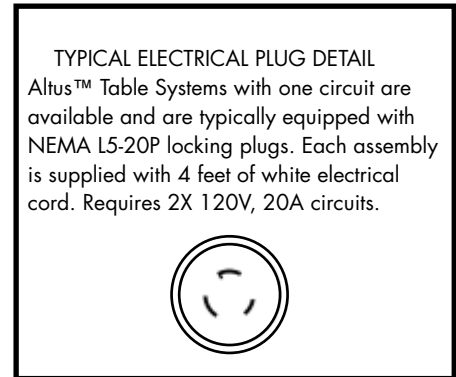

TYPICAL ELECTRICAL PLUG DETAIL
Altus™ Table Systems with one circuit are available and are typically equipped with NEMA L5-20P locking plugs. Each assembly is supplied with 4 feet of white electrical cord. Requires 2X 120V, 20A circuits.

All electrical receptacles and data are white.

Wiring Option A

Option code "D2": 2 Circuits

48", 60", 72" Wide Assembly

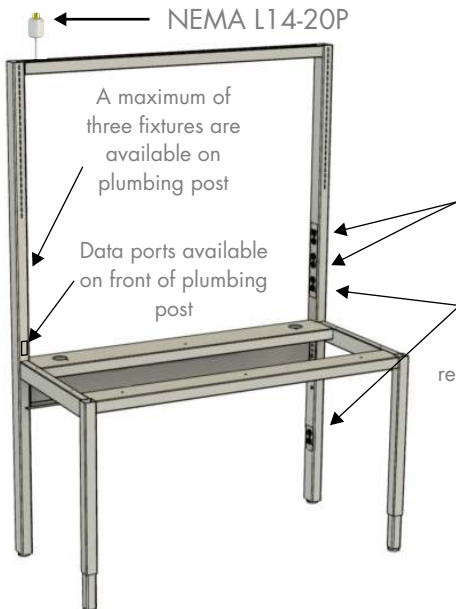

Circuit 1
Two duplex receptacles on electrical post

Circuit 2
One duplex receptacle on electrical post below worksurface

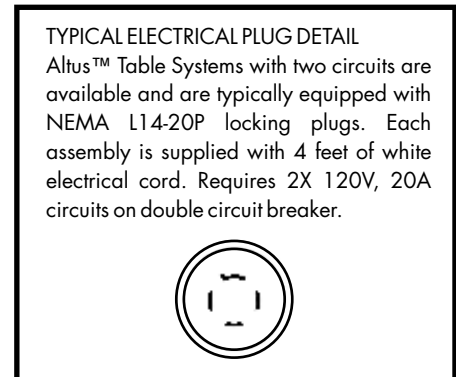

TYPICAL ELECTRICAL PLUG DETAIL
Altus™ Table Systems with two circuits are available and are typically equipped with NEMA L14-20P locking plugs. Each assembly is supplied with 4 feet of white electrical cord. Requires 2X 120V, 20A circuits on double circuit breaker.

All electrical receptacles and data are white.

ALTUS™ TABLE SYSTEM

Assembly



Width	23" Deep	29" Deep
48"	ATS2348	ATS2948
60"	ATS2360	ATS2960
72"	ATS2372	ATS2972

- Available in powder coated steel finish or stainless steel.
- Overall assembly is 84" high, 2" X 3" deep rear posts, 2" square tubular front legs with leveling feet. Table frame is an all-welded construction. Table frame is height adjustable in 1" increments from 29" to 36" (work surface not included).
- Complete with hanging rails to suspend lower cabinets on units 72" wide and smaller.
- Standard depth hanging cabinets are not suitable for 23" deep tables.
- To order suspended base cabinets, mobile cabinets, pencil drawers and pull out writing tablets refer to those catalog sections.
- A maximum of three fixtures are available on the plumbing post.
- Three duplex electrical receptacles are standard on side electrical post (data an available option).
- Overall depth of assembly does not include work surface.
- Shipped partially assembled.

Four Leg Table



Width	22" Deep	28" Deep
48"	ATF2248	ATF2848
60"	ATF2260	ATF2860
72"	ATF2272	ATF2872

- Available in powder coated steel finish or stainless steel.
- Table frame is an all-welded construction. 2" square tubular legs with leveling feet. Table frame is height adjustable in 1" increments from 29" to 36" (work surface not included).
- Table frame complete with hanging rails to suspend lower cabinets.
- Standard depth hanging cabinets are not suitable for 22" deep tables.
- To order suspended base cabinets, mobile cabinets, pencil drawers and pull out writing tablets refer to those catalog sections.
- Shipped assembled.

Altus™ Caster Option



- When option code 97 is applied to the Altus™ table system, the table comes with leveling casters, side and rear supports.
- When casters are supplied, the load rating is reduced, contact Mott for details.

Note: This caster option invalidates the UL listing on the Altus™.

Altus™ Crank-Operated Option



- To add the crank adjustable system to an Altus™ please contact Mott Manufacturing for ordering details.
- Crank-operated table frame adjustability from 28-3/4" to 39-3/4", work surface not included.
- Legs are supplied with leveling feet.
- Contact Mott for maximum load rating.

Note: This crank option invalidates the UL listing on the Altus™.

ALTUS™ TABLE SYSTEM

WORK SURFACES

Work Surface for 23" Deep & 29" Deep Units

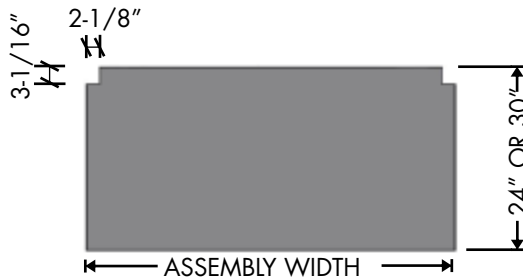

Width of Bench	Black Epoxy		Stainless Steel	
	24" Deep	30" Deep	24" Deep	30" Deep
48"	EAL2448	EAL3048	SAL2448	SAL3048
60"	EAL2460	EAL3060	SAL2460	SAL3060
72"	EAL2472	EAL3072	SAL2472	SAL3072

- Stainless steel work surfaces are type 304-4, flat, square edges, 1" thick.
- Epoxy work surfaces with 1/8" [3mm] beveled edges are 1" thick. The cutouts for posts are not beveled.
- 1" overhang at front.

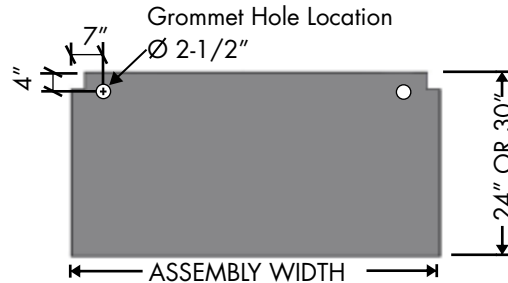

Width of Bench	Black Epoxy		Stainless Steel	
	24" Deep	30" Deep	24" Deep	30" Deep
48"	EAH2448	EAH3048	SAH2448	SAH3048
60"	EAH2460	EAH3060	SAH2460	SAH3060
72"	EAH2472	EAH3072	SAH2472	SAH3072

- Grommet hole cutout available in work surface when lower raceway option is ordered.
- Stainless steel work surfaces are type 304-4, flat, square edges, 1" thick.
- Epoxy work surfaces with 1/8" [3mm] beveled edges are 1" thick. The cutouts for posts are not beveled.
- 1" overhang at front.

Four Leg Table Work Surface For 22" Deep & 28" Deep Units

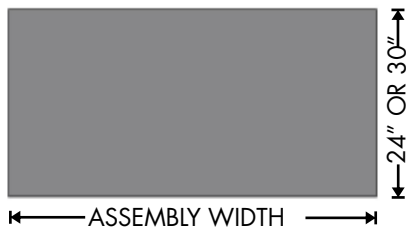

Width of Bench	Black Epoxy		Stainless Steel	
	24" Deep	30" Deep	24" Deep	30" Deep
48"	EAT2448	EAT3048	SAT2448	SAT3048
60"	EAT2460	EAT3060	SAT2460	SAT3060
72"	EAT2472	EAT3072	SAT2472	SAT3072

- Stainless steel work surfaces are type 304-4, flat, square edges, 1" thick.
- Epoxy work surfaces with 1/8" [3mm] beveled edges are 1" thick. The cutouts for posts are not beveled.
- 1" overhang at front and back.

ALTUS™ TABLE SYSTEM

STEEL SHELF COMPONENTS

Altus™ Steel Shelf Assembly

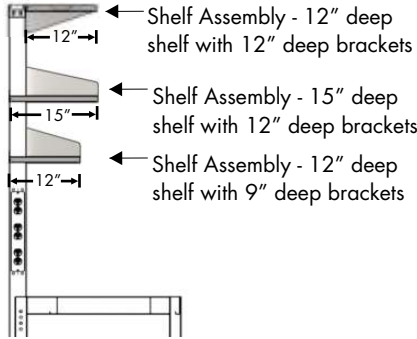

Top Steel Shelf Assemblies



Radius Profile

Width of Bench	Tapered Profile	Radius Profile
48"	AAS1248	AAR1248
60"	AAS1260	AAR1260
72"	AAS1272	AAR1272

- Assembly includes one 1" thick 12" deep shelf and a pair of 12" deep brackets. Also available in stainless steel.
- Shelves are adjustable in 1" increments.
- Suitable for Altus™ only.
- All width dimensions are nominal.

Steel Shelf Assemblies



Radius Profile

Width of Bench	12" Deep Assembly		15" Deep Assembly	
	Tapered Profile	Radius Profile	Tapered Profile	Radius Profile
48"	SAA1248	SRA1248	SAA1548	SRA1548
60"	SAA1260	SRA1260	SAA1560	SRA1560
72"	SAA1272	SRA1272	SAA1572	SRA1572

- Assembly includes one 1" thick shelf, one rear shelf angle, one 12" deep or 15" deep shelf and a pair of brackets. (9" brackets for 12" deep assembly, 12" deep brackets for 15" deep assembly). Also available in stainless steel.
- Shelves are adjustable in 1" increments.
- Suitable for Altus™ only.
- All width dimensions are nominal.

Retainer Rods For Shelf Assemblies



Retainer Rod Option Codes	
Powder Coated Steel	Stainless Steel
CR	SR

- 1" high retainer rod (5/16" dia.) prevents articles from falling off the shelf.
- Shelves receive one retainer rod and three turrets on 48" wide and 60" wide shelves and one retainer rod and four turrets on 72" wide shelves.
- Available in stainless steel or powder coated stainless.
- Retainer rod ships loose.

ALTUS™ TABLE SYSTEM

WOOD SHELF COMPONENTS

Altus™ Wood Shelves

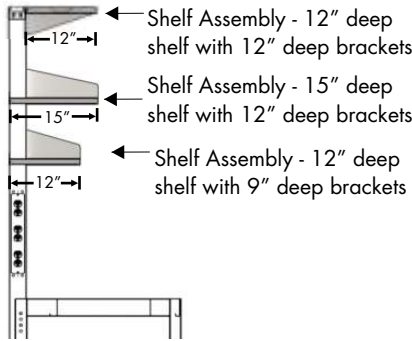

Wood Shelves for 12" Deep Top Shelf Brackets



Width of Bench	Item Number
48"	AAS1248W
60"	AAS1260W

- Shelves are 1" thick. Shelves are suitable for Altus™ only.
- Shelf brackets are not included and must be ordered separately.
- To add wood lips or valances to shelves see page R7 for option codes.
- 72" wide wood shelves not available.
- See page R7 for non-Mott shelf dimensions.
- All width dimensions are nominal.

Top Shelf Brackets



Depth	Tapered Profile	Radius Profile
12"	TBA0012	TBA3012

- One pair of powder coated steel end brackets for Top Shelves. Designed to be used for shelves of different materials, mounts to slotted post. Available in stainless steel. Suitable for Altus™ only.
- Adjustable in 1" increments.
- See page R7 for non-Mott shelf dimensions.

Wood Shelves for 9" Deep & 12" Deep Shelf Brackets



Width of Bench	Shelves for 9" Bracket	Shelves for 12" Bracket
48"	SAA1248W	SAA1548W
60"	SAA1260W	SAA1560W

- Shelves are 1" thick. Shelves are suitable for Altus™ only.
- Shelf brackets are not included and must be ordered separately.
- To add wood lips or valances to shelves see page R7 for option codes.
- 72" wide wood shelves not available.
- All width dimensions are nominal.

Shelf Brackets



Depth	Tapered Profile	Radius Profile
9"	SBA0009	SBA3009
12"	SBA0012	SBA3012

- One pair of powder coated steel end brackets designed to be used for shelves of different materials, mounts to slotted post. Available in stainless steel. Suitable for Altus™ only.
- Adjustable in 1" increments.
- See page R7 for non-Mott shelf dimensions.

ALTUS™ TABLE SYSTEM

SHELF COMPONENTS

Wood Shelving Options

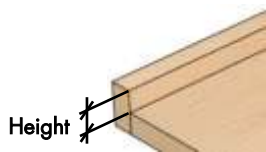

- Height of the lip is measured from the top of the shelf to the top of the lip. Lip is 3/4" thick.
- Shelves are 1" thick.

Height	Back Lip	Front Lip	Back & Front Lip
1"	ARW1	AFW1	ABW1
2"	ARW2	AFW2	ABW2
3"	ARW3	AFW3	ABW3
4"	ARW4	AFW4	ABW4

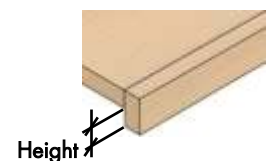

- Height of the valance is measured from the bottom of the shelf to the bottom of the valance. Valance is 3/4" thick.
- Shelves are 1" thick.

Height	Front Valance
1"	FV1
2"	FV2
3"	FV3
4"	FV4

Retainer Rods For Shelf Assemblies



Retainer Rod option Code	
Powder Coated	Stainless Steel
CR	SR

- 1" high retainer rod (5/16" dia.) prevents articles from falling off the shelf.
- Shelves receive one retainer rod and three turrets on 48" wide and 60" wide shelves and one retainer rod and four turrets on 72" wide shelves.
- Available in stainless steel or powder coated stainless.
- Retainer rod ships loose.

Metal Shelf Angles



Width of Bench	Item Number	Shelf Angles Included
48"	ARS2148	1
60"	ARS2160	1
72"	ARS2172	1

- Metal shelf angles can be added to any existing Altus™ shelf and are used to stop items from sliding off of shelving.
- 2" high with a 1" return and notched for shelf brackets. Also available in stainless steel.
- Ships loose.

Shelf Retainer Rods

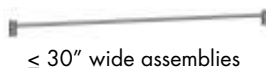

≤ 30" wide assemblies



> 30" wide assemblies

Bench Width	Steel Shelves		Wood Shelves		Retainer Rod Parts
	Powder Coated	Stainless Steel	Powder Coated	Stainless Steel	
48"	PRR0048-AT	SRR0048-AT	PRR0048-ATW	SRR0048-ATW	1 rod & 3 turrets
60"	PRR0060-AT	SRR0060-AT	PRR0060-ATW	SRR0060-ATW	1 rod & 3 turrets
72"	PRR0072-AT	SRR0072-AT	-	-	1 rod & 4 turrets

- 1" high retainer rod (5/16" dia.) prevents articles from falling off the shelf.
- Retainer rods are measured on centers.
- Can be added to existing Altus™ shelves.
- Available in stainless steel or powder coated stainless steel.
- Threaded turrets includes hardware for mounting to shelf (shelf must have holes drilled to accept turrets).
- Ships loose.
- AT and ATW at the end of the part numbers represent option codes.

Dimensions For Non-Mott Shelf On A 9" Bracket & 12" Bracket

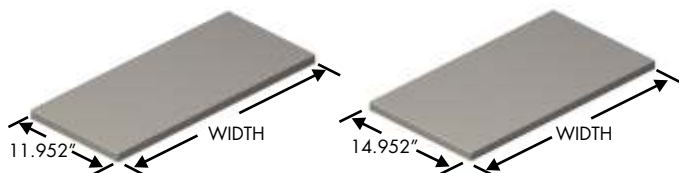

Typical shelf dimensions for non-Mott shelves:

- Quantity of 1 - 43.550" wide shelf is suits a 48" wide
- Quantity of 1 - 55.550" wide shelves suits a 60" wide
- Quantity of 1 - 67.550" wide shelves suits a 72" wide

ALTUS™ TABLE SYSTEM

COMPONENTS

Under Mount Shelf Task Lights

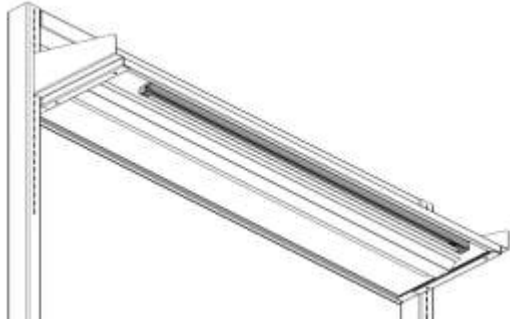

Length of Light	Item Number
14"	TLW0014
23"	TLW0023
36"	TLW0036
48"	TLW0048
59"	TLW0059

- Order light a minimum 6" shorter than the shelf.
- Low profile (.98" wide by 1.65" high) T5 white fluorescent task light mounts to underside of the shelf.
- Task light to be plugged into the raceway.
- Shatterproof polycarbonate lens protects the lamp.
- Easily linkable in one continuous line using Flexible Connectors. 6" Flexible Connector and 6' power plug comes standard with each light. See below to order longer Flexible Connectors.
- On-off rocker switch located on the side of the fixture.
- 8000 hour, cool white replaceable T5 lamp included.
- UL listed.
- Ships loose, includes Mott's mounting brackets.

Task Light Flexible Connectors



Length	Item Number
12"	LFC0012
24"	LFC0024
36"	LFC0036

- Flexible Connector allows to easily link T5 fluorescent lights in one continuous line.

LCD Monitor Arms



Anodized Silver Finish	Black Finish
MONARMS	MONARMB

- Position your LCD for maximum productivity and comfort.
- Features foldable arms which adjust vertically up and down a 12" pole. The arms can fold up to fit in about 3" of space and extend out 14". Rotates 360 degrees at three joints, monitor tilting mechanism can tilt over 200 degrees and adjustable tension at joints which is ideal for touch-screen applications.
- Weight capacity adjusts to hold up to 40lbs (Monitor depth greater than 2" may diminish capacity). Monitor not included.
- Easily attaches to LCDs that are VESA MIS-D, 100/75, compliant.
- Ships loose.

Back-To-Back Fastener Kit



Item Number
ABF0000

- Bracket attaches to the bottom of the rear post legs to stabilize two assemblies that are situated back-to-back.
- Kit available in stainless steel.
- Hardware not included.
- Suitable for Altus™ only.

Side-To-Side Fastener Kit



Item Number
ASF0000

- Bracket attaches to the bottom of the rear post legs to stabilize two assemblies that are situated side-to-side.
- Kit available in stainless steel.
- Hardware not included.
- Suitable for Altus™ only.

ALTUS™ TABLE SYSTEM

SERVICE FIXTURES

Female Ceiling Quick Connect Fittings



The customer is responsible for ensuring that internal piping and components meet local codes and standards. In some jurisdictions on-site inspection and testing may be required, this service is not provided by Mott Manufacturing.

For Coiled & Straight Hose		
Service	Band Color	Item Number
AIR	Orange	MCPVAIR
ARG	Violet	MCPVARG
CW	Green	MCPVCWT
GAS	Blue	MCPVGAS
HE	Black	MCPVEL
NIT	Brown	MCPVNIT
VAC	Yellow	MCPVAC

- These parts are shipped loose.
- A panel mounted stainless steel keyed quick connect body is suitable for panel mounting on overhead service carriers and Ceiling Service Panels with stainless steel hoses.
- A panel mounted brass keyed quick connect body is suitable for panel mounting on overhead service carriers and Ceiling Service Panels with Straight hoses.
- Complete with 3/8" NPT inlet.
- Only plug and body quick connects of the same color will couple and allow flow.

Service Assemblies



Altus™ Service	Band Color	White Hose	Stainless Hose
AIR	Orange	ASAPAIR	-
ARG	Violet	ASAPARG	-
CW	Green	ASAPCWT	-
GAS	Blue	-	ASASGAS
HE	Black	ASAPHEL	-
NIT	Brown	ASAPNIT	-
VAC	Yellow	ASAPVAC	-

- These parts are shipped loose.
- Assembly complete with panel mounted single service fixture (Needle Valve supplied, Note: * Cold Water is supplied with ball valve), keyed quick connect plug and hose.
- Corrugated gas appliance connector with stainless steel keyed quick connect is supplied for burning gas.
- These assemblies are only suitable for the Altus™ Tables.
- Supplied with 4 feet of service lines above table height.
- Only plug and body quick connects of the same color will couple and allow flow.
- Fixtures may not be exactly as shown.
- Epoxy coated fixtures.