

OVERHEAD SERVICE DISTRIBUTION

SUSPENDED AVION™

Suspended Avion™

The Avion™ houses all services such as electrical, data, telephone, local exhaust systems and light as well as all of the usual plumbing services. They provide maximum flexibility as services are lifted off the floor, allowing free floor space to be configured as needed. The Avion™ is designed to work off a grid supply system that allows the carrier to be easily relocated to a different section of the laboratory and can be ganged end to end in a continuous linear configuration.



Bottom Views - Without Lights

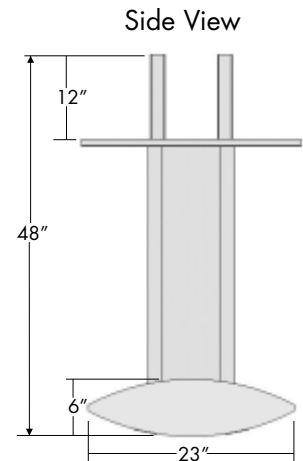
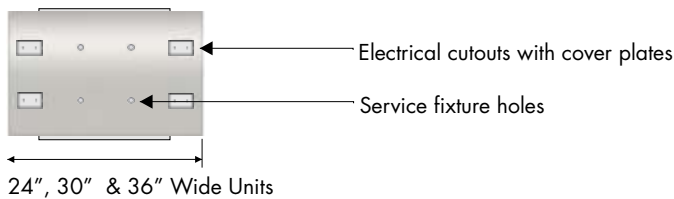
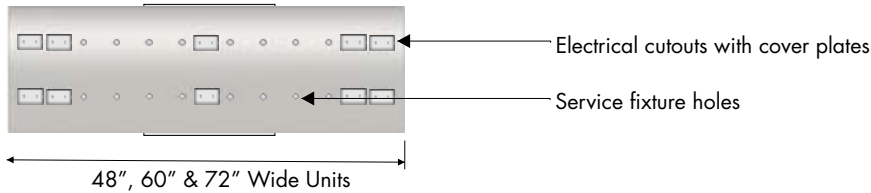

Bottom Views - With Lights

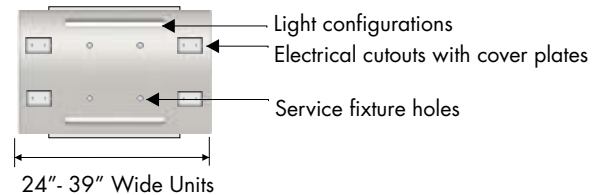
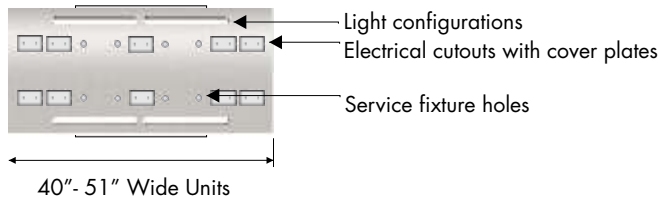
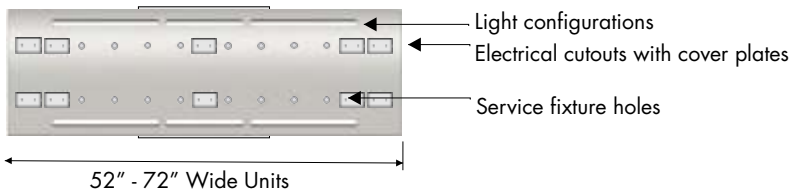

**OVERHEAD SERVICE DISTRIBUTION**

**SUSPENDED AVION™**

Suspended Avion™ Carriers

Recommendation For Fastening: Due to differences in structure and materials of ceiling, the best method mounting the overhead carrier(s) to the ceiling will be dictated by field conditions and determined by local engineers. Ceiling post assemblies should be secured to the contractor/installer provided bracing or framing. Mounting hardware is supplied by the installer.

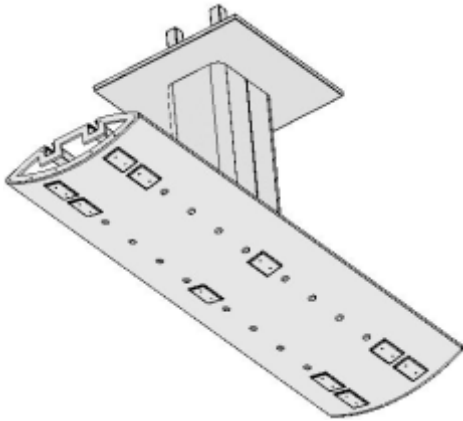

Width	With Lights	Without Lights
24"	OHA1024	OHA2024
30"	OHA1030	OHA2030
36"	OHA1036	OHA2036
48"	OHA1048	OHA2048
60"	OHA1060	OHA2060
72"	OHA1072	OHA2072

- Fixture holes are plugged with ABS plastic caps.
- Carrier body is 6" high x 23" deep.
- End Caps must be ordered separately.
- If wiring is ordered, 3' of electrical whip (above vertical column top) is provided.
- T5 fluorescent lights are included on OHA10XX part numbers.
- Add option code AC for Dust Cap for Avion™ Carrier.

Carrier End Cap

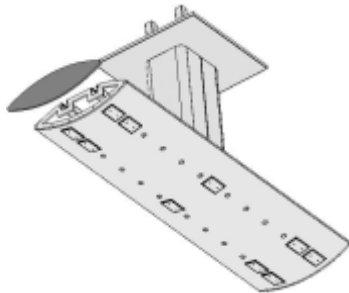

Item Number

OHA0000

- Single cover cap used to enclose uncovered ends of carrier body (two end caps are required for each carrier, item number is for one end cap only).
- Hardware to mount end cap is included.
- Suitable for Avion™ carrier only.

Connector Plates

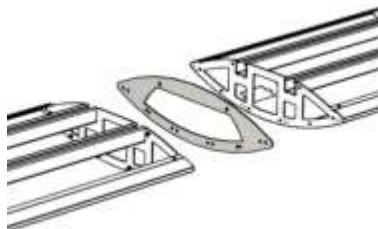

Item Number

OHA1000

- Plate used to join two Avion™ carriers end to end.
- Mounting hardware not included.
- Suitable for Avion™ carrier only.

Mounting Brackets



Item Number

OHA2000

- Brackets used to mount Avion™ carriers to building structure.
- Hardware to mount brackets to Avion™ included (no other hardware supplied).
- Suitable for Avion™ carrier only.