

SIGMA CARTS™
Sigma Carts™

Sigma Carts™ are ideal solutions to workstations that require high levels of durability, mobility, adjustability, and adaptability all with a contemporary design. These carts can be easily integrated either into existing work spaces or to locate them as independent self supporting work stations, which makes them ideal for sharing instrumentation, tools, or processes within the same laboratory area. Individual carts can be joined together and connected to overhead service carriers to create larger modular work units.

Full Height and Low Sigma Carts™ are offered in two different depths and are available in various widths. Sigma Carts™ can be configured with a broad range of accessories including adjustable work surfaces, suspended upper and lower cabinets, adjustable shelving, electrical raceways, task lighting, peg boards, tack boards, and marker boards.

Convenient height adjustment allows custom adaptation to specific operator and/or process requirements.

Load Ratings

Sigma Cart™ assembly consists of cart frame and cantilevered table frame. Order suspended cabinets, wall cabinets, shelves and accessories separately.

Maximum load ratings are live loads and include loads applied to top of work surface, including total weight of shelves and suspended cabinetry and other accessories. These capacities should be used as guidelines only. Please contact Mott Manufacturing for specific load requirements. Maximum load ratings are based on the load being evenly balanced. Individual component or assembly load ratings should not be exceeded for any surface.

Maximum Load Ratings Per Cart

- | | |
|-----------------------|--------|
| • Single work surface | 600lbs |
| • Split work surface | 300lbs |
| • Total Shelving | 300lbs |
| • Total Load Rating | 900lbs |

For ordering suspended cabinets and wall cabinets refer to those sections in the catalog.

SIGMA CART™

36" HIGH

Low Cart Assemblies



Low Cart Assembly is 35-3/4" high with 1" work top installed.

Width	23" Deep	29" Deep
24"	MWS2024	MWS2124
30"	MWS2030	MWS2130
36"	MWS2036	MWS2136
42"	MWS2042	MWS2142
48"	MWS2048	MWS2148
54"	MWS2054	MWS2154
60"	MWS2060	MWS2160
72"	MWS2072	MWS2172

- Low cart assembly is 35-3/4" high and comes complete with cantilevered table frame, height adjustable in 1" increments (work surface not included).
- Upper Cart assembly can be added in the future.
- Shelves can be installed below work surface (accepts standard Sigma Flex™ shelves).
- Hanging rails are included on table frame to suspend lower cabinets.
- Total lock steel swivel casters.
- Overall depth of cart is 30" deep with 23" deep table frame.
- Overall depth of cart is 36" deep with 29" deep table frame.
- Shipped assembled.

Typical Sigma Cart™ work top for 23" and 29" deep units.

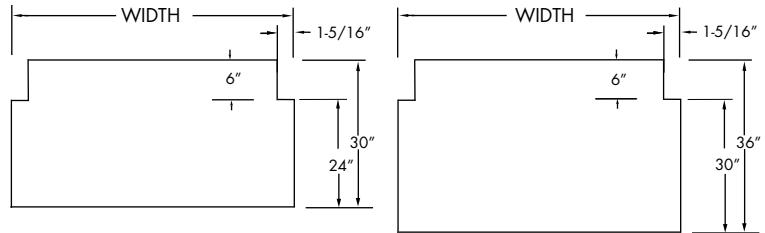

Low Double Cart Assemblies



Low Double Cart Assembly is 35-3/4" high with 1" work top installed.

Width	23" Deep	29" Deep
60"	MWD2060	MWD2160
72"	MWD2072	MWD2172

- Low cart double assembly is 35-3/4" high and comes complete with cantilevered table frame, height adjustable in 1" increments (work surface not included).
- Assembly is 60" or 72" wide with middle upright being centered.
- Upper Cart assembly can be added in the future.
- Shelves can be installed below work surface (accepts standard Sigma Flex™ shelves).
- Hanging rails are included on table frame to suspend lower cabinets.
- Total lock steel swivel casters.
- Overall depth of cart is 30" deep with 23" deep table frame.
- Overall depth of cart is 36" deep with 29" deep table frame.
- Shipped assembled.

Typical Sigma Cart™ work top for 23" and 29" deep units.

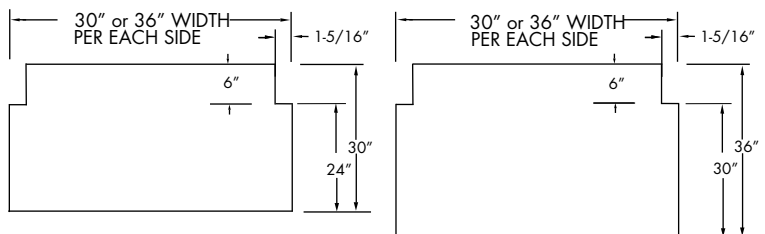

SIGMA CART™
78" HIGH

Full Height Cart Assemblies

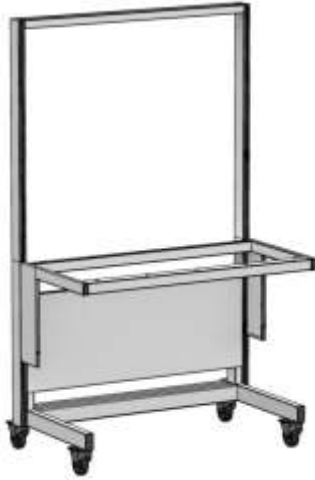

Width	23" Deep	29" Deep
24"	MWS1024	MWS1124
30"	MWS1030	MWS1130
36"	MWS1036	MWS1136
42"	MWS1042	MWS1142
48"	MWS1048	MWS1148
54"	MWS1054	MWS1154
60"	MWS1060	MWS1160
72"	MWS1072	MWS1172

- One piece full height cart assembly is 78" high and comes complete with cantilevered table frame, height adjustable in 1" increments (work surface is not included).
- Shelves can be installed above and below work surface (accepts standard Sigma Flex™ shelves).
- Hanging rails are included on table frame to suspend lower cabinets.
- Total lock steel swivel casters.
- Overall depth of cart is 30" deep with 23" deep table frame.
- Overall depth of cart is 36" deep with 29" deep table frame.
- Shipped assembled.

Typical Sigma Cart™ work top for 23" and 29" deep units.

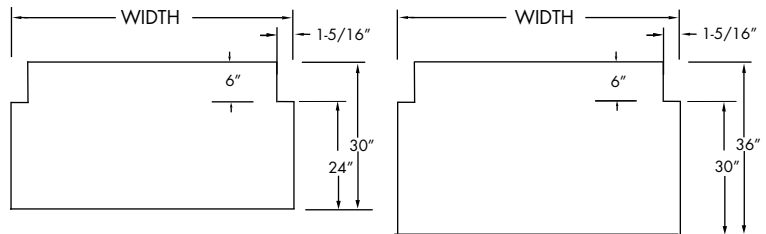

Full Height Double Cart Assemblies



Width	23" Deep	29" Deep
60"	MWD1060	MWD1160
72"	MWD1072	MWD1172

- One piece full height cart double assembly is 78" high and comes complete with cantilevered table frame, height adjustable in 1" increments (work surface is not included).
- Shelves can be installed above and below work surface (accepts standard Sigma Flex™ shelves).
- Hanging rails are included on table frame to suspend lower cabinets.
- Total lock steel swivel casters.
- Overall depth of cart is 30" deep with 23" deep table frame.
- Overall depth of cart is 36" deep with 29" deep table frame.
- Shipped assembled.

Typical Sigma Cart™ work top for 23" and 29" deep units.

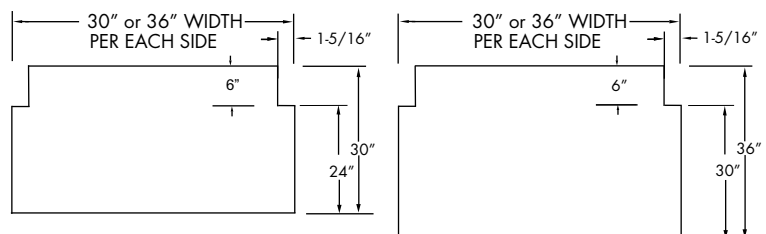

SIGMA CART™

COMPONENTS

Upper Cart Assemblies - 43-1/4" High



Width	Item Number
24"	MWS3024
30"	MWS3030
36"	MWS3036
42"	MWS3042
48"	MWS3048
54"	MWS3054
60"	MWS3060
72"	MWS3072

- One piece upper cart assembly is 43-1/4" high.
- Mounts on top of low cart to create a full height assembly.
- Specify two 30" or 36" wide uppers for 60" or 72" low double cart assembly.
- Shelves can be installed (accepts standard Sigma Flex™ shelves).
- Shipped assembled.
- Hardware included.

Wall Cabinet Hanger Rails

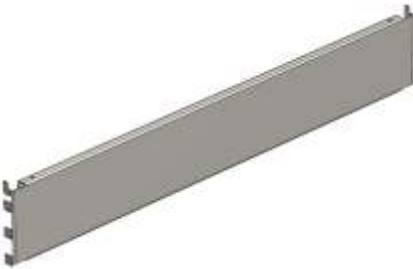

Width	Item Number
24"	FWR0024
30"	FWR0030
36"	FWR0036
42"	FWR0042
48"	FWR0048
54"	FWR0054
60"	FWR0060
72"	FWR0072

- A Wall Cabinet Hanger Rail is required to hang above-counter storage cabinets on to Sigma Flex™ and Sigma Cart™ products.
- Order rails to match width of support structure frame.
- See wall cabinet section to order cabinets.
- Wall cabinets must be ordered with option code FR to suspend from Sigma Flex™ and Sigma Cart™ products.

Sigma Cart™ Cover Panels

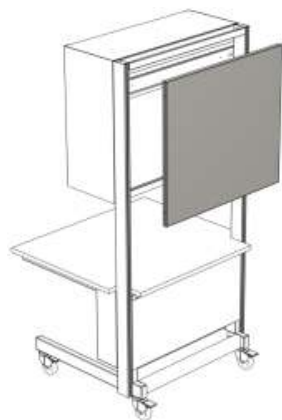

Cart Width	Wall Cabinet Height				
	16-1/2" High	24" High	30" High	36" High	48" High
24"	-	FFB2424	FFB2430	FFB2436	FFB2448
30"	FFB3016	FFB3024	FFB3030	FFB3036	FFB3048
36"	FFB3616	FFB3624	FFB3630	FFB3636	FFB3648
42"	-	FFB4224	FFB4230	FFB4236	FFB4248
48"	FFB4816	FFB4824	FFB4830	FFB4836	FFB4848
54"	-	FFB5424	FFB5430	FFB5436	FFB5448
60"	-	FFB6024	FFB6030	FFB6036	FFB6048
72"	-	FFB7224	FFB7230	FFB7236	FFB7248

- Finished back panel for wall cabinets to hang on Full Height Cart assembly.
- 16-1/2" high Sigma Cart™ Cover Panel suits a Flipper Door wall cabinet.
- "S" clips provided by Mott.
- See wall cabinet section to order cabinets.
- Wall cabinets must be ordered with option code "FR" to suspend from cart.
- Cannot attach peg boards or marker boards to Sigma™ Cover Panels.

Stationary Feet



Option Code

- SF
- Add Option Code SF to order stationary feet with levelers to Sigma Cart™ assembly.

SIGMA CART™

COMPONENTS

Supplementary Adjustable Legs



Option Code

AL

- Add Option Code AL to order Supplementary Adjustable Legs to Sigma Cart™ assembly (Supplementary Legs are NOT to be used with Double Cart assemblies).
- Pair of hinged Supplementary Adjustable Legs are used to increase the load bearing capacity of the work surface from 600lbs to 1000lbs. Total load of cart should not exceed 1200lbs.
- Ships assembled on Sigma Carts™.

Back-to-Back Fastener

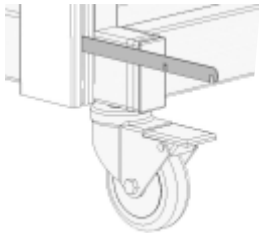

Item Number

BBB0000

- Stainless steel bracket suitable for any Sigma Cart™.
- Bracket attaches to cart uprights to stabilize two carts that are situated back-to-back.

Side-to-Side Fastener

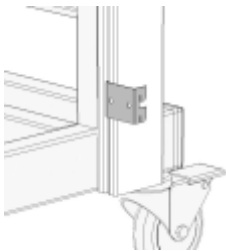

Item Number

SSB0000

- Powder coated steel bracket suitable for any Sigma Cart™.
- Bracket attaches to cart uprights to stabilize two carts that are situated side-to-side.
- Can be used to gang Sigma Carts™ end-to-end for a continuous run.

Power Strip Brackets



Item Number

PSB0000

- Pair of brackets to mount power strips (power strips not included).
- Allows the power strips to sit flush against the back edge of the brackets.

Power Strip Rail With Brackets



Width Item Number

24" PSR0024

30" PSR0030

36" PSR0036

42" PSR0042

48" PSR0048

54" PSR0054

60" PSR0060

72" PSR0072

- 2-1/8" high power strip rail with brackets for mounting of power strips (power strips not included).

SIGMA CART™

SHELF COMPONENTS

Shelves

Sigma Carts™ are designed and manufactured to accommodate upper and below work surface shelving.

Outer and Top Shelves



- Shelf suitable for any Sigma Flex™ structure or Sigma Cart™.
- Attach to shelf brackets with screws (screws not included).
- Nominal width.
- To order Shelf Task Light refer to Steel Miscellaneous Section.

Steel Shelves						
Width	6"Depth	8"Depth	10"Depth	12"Depth	14" Deep	18" Deep
24"	FSH0624	FSH0824	FSH1024	FSH1224	FSH1424	FSH1824
30"	FSH0630	FSH0830	FSH1030	FSH1230	FSH1430	FSH1830
36"	FSH0636	FSH0836	FSH1036	FSH1236	FSH1436	FSH1836
42"	FSH0642	FSH0842	FSH1042	FSH1242	FSH1442	FSH1842
48"	FSH0648	FSH0848	FSH1048	FSH1248	FSH1448	FSH1848
54"	FSH0654	FSH0854	FSH1054	FSH1254	FSH1454	FSH1854
60"	FSH0660	FSH0860	FSH1060	FSH1260	FSH1460	FSH1860
66"	FSH0666	FSH0866	FSH1066	FSH1266	FSH1466	FSH1866
72"	FSH0672	FSH0872	FSH1072	FSH1272	FSH1472	FSH1872

Steel Shelf Angles

- Shelf with rear angle is suitable for any Sigma Flex™ structure or Sigma Cart™.
- Use option codes below to add angles to steel shelves only:
 - AR (Rear Shelf Angle welded to shelf)
 - AF (Front Shelf Angle welded to shelf)
 - AB (Rear and Front Shelf Angle welded to shelf)

Wood Shelves						
Width	6"Depth	8"Depth	10"Depth	12"Depth	14" Deep	18" Deep
24"	FSH0624W	FSH0824W	FSH1024W	FSH1224W	FSH1424W	FSH1824W
30"	FSH0630W	FSH0830W	FSH1030W	FSH1230W	FSH1430W	FSH1830W
36"	FSH0636W	FSH0836W	FSH1036W	FSH1236W	FSH1436W	FSH1836W
42"	FSH0642W	FSH0842W	FSH1042W	FSH1242W	FSH1442W	FSH1842W
48"	FSH0648W	FSH0848W	FSH1048W	FSH1248W	FSH1448W	FSH1848W
54"	FSH0654W	FSH0854W	FSH1054W	FSH1254W	FSH1454W	FSH1854W
60"	FSH0660W	FSH0860W	FSH1060W	FSH1260W	FSH1460W	FSH1860W

Wood Shelf Front Valance



Height	Front Valance
1"	FV1
2"	FV2
3"	FV3
4"	FV4

- Height of the valance is measured from the bottom of the shelf to the bottom of the valance.
- Valance is 3/4" thick. Shelves are 1" thick.

Wood Shelf Front & Back Lip

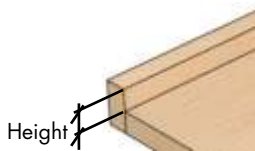

Height	Back Lip	Front Lip	Back & Front Lip
1"	ARW1	AFW1	ABW1
2"	ARW2	AFW2	ABW2
3"	ARW3	AFW3	ABW3
4"	ARW4	AFW4	ABW4

- Height of the lip is measured from the top of the shelf to the top of the lip. Lip is 3/4" thick.
- Shelves are 1" thick.

Shelf Retainer Rods

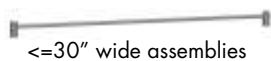

<=30" wide assemblies



>30" wide assemblies

Width	Steel Shelves		Wood Shelves		Retainer Rod Sizes Measured On Centers
	Powder Coated	Stainless Steel	Powder Coated	Stainless Steel	
24"	PRR0024-FX	SRR0024-FX	PRR0024-FXW	SRR0024-FXW	1 Rod & 2 Turrets
30"	PRR0030-FX	SRR0030-FX	PRR0030-FXW	SRR0030-FXW	1 Rod & 2 Turrets
36"	PRR0036-FX	SRR0036-FX	PRR0036-FXW	SRR0036-FXW	1 Rod & 3 Turrets
42"	PRR0042-FX	SRR0042-FX	PRR0042-FXW	SRR0042-FXW	1 Rod & 3 Turrets
48"	PRR0048-FX	SRR0048-FX	PRR0048-FXW	SRR0048-FXW	1 Rod & 3 Turrets
54"	PRR0054-FX	SRR0054-FX	PRR0054-FXW	SRR0054-FXW	1 Rod & 3 Turrets
60"	PRR0060-FX	SRR0060-FX	PRR0060-FXW	SRR0060-FXW	1 Rod & 3 Turrets
66"	PRR0066-FX	SRR0066-FX	PRR0066-FXW	SRR0066-FXW	1 Rod & 4 Turrets
72"	PRR0072-FX	SRR0072-FX	-	-	1 Rod & 4 Turrets

- 1" high retainer rod (5/16" dia.) prevents articles from falling off the shelf.
- Retainer rods are measured on centers.
- Can be added to existing shelves.
- Available in stainless steel or powder coated stainless steel.
- Threaded turrets includes hardware for mounting to shelf (shelf must have holes drilled to accept turrets).
- Ships loose.
- FX and FXW at the end of the part numbers represent option codes.

SIGMA CART™
SHELF COMPONENTS
15° Angled Outer Shelf Brackets

Depth	Item Number
10"	ASB0010
12"	ASB0012
14"	ASB0014
18"	ASB0018

- Pair of steel end brackets designed to fit Outer Shelves and can be used for shelves of different materials.
- Shelf brackets designed at a fixed 15 degree angle.
- Adjustable in 1" increments.
- Brackets only compatible with Sigma Flex™ structure or Sigma Cart™.

Outer Shelf Brackets

Depth	Item Number
6"	FSB0006
8"	FSB0008
10"	FSB0010
12"	FSB0012
14"	FSB0014
18"	FSB3018

- Pair of top end shelf brackets, can be used for shelves of different materials.
- Adjustable in 1" increments.
- Only compatible with Sigma Flex™ structure or Sigma Cart™.

Radius Outer Shelf Brackets

Depth	Item Number
6"	FSB3006
8"	FSB3008
10"	FSB3010
12"	FSB3012
14"	FSB3014
18"	FSB3018

- Pair of top end shelf brackets, can be used for shelves of different materials.
- Adjustable in 1" increments.
- Only compatible with Sigma Flex™ structure or Sigma Cart™.

Tapered Outer Shelf Brackets

Depth	Item Number
6"	FSB4006
8"	FSB4008
10"	FSB4010
12"	FSB4012
14"	FSB4014
18"	FSB4018

- Pair of top end shelf brackets, can be used for shelves of different materials.
- Adjustable in 1" increments.
- Only compatible with Sigma Flex™ structure or Sigma Cart™.

Top Shelf Brackets

Depth	Item Number
6"	FIB0006
8"	FIB0008
10"	FIB0010
12"	FIB0012
14"	FIB0014
18"	FIB0018

- Pair of top end shelf brackets, can be used for shelves of different materials.
- Adjustable in 1" increments.
- Only compatible with Sigma Flex™ structure or Sigma Cart™.

Radius Top Shelf Brackets

Depth	Item Number
6"	FIB3006
8"	FIB3008
10"	FIB3010
12"	FIB3012
14"	FIB3014
18"	FIB3018

- Pair of top end shelf brackets, can be used for shelves of different materials.
- Adjustable in 1" increments.
- Only compatible with Sigma Flex™ structure or Sigma Cart™.

Tapered Top Shelf Brackets

Depth	Item Number
6"	FIB4006
8"	FIB4008
10"	FIB4010
12"	FIB4012
14"	FIB4014
18"	FIB4018

- Pair of top end shelf brackets, can be used for shelves of different materials.
- Adjustable in 1" increments.
- Only compatible with Sigma Flex™ structure or Sigma Cart™.