

MISCELLANEOUS ITEMS

Front Filler Panels



- The Front Filler Panel is used to close a space between two base cabinets.
- Filler panels can be ordered in 1" increments, up to 24" wide. Change the last two digits to the dimension required.

Width	Standing Ht.	Sitting Ht.	ADA Ht.	84" High
1"	FFC1001W	FFC2001W	FFC8001W	FFC3001W
2"	FFC1002W	FFC2002W	FFC8002W	FFC3002W
4"	FFC1004W	FFC2004W	FFC8004W	FFC3004W
6"	FFC1006W	FFC2006W	FFC8006W	FFC3006W
8"	FFC1008W	FFC2008W	FFC8008W	FFC3008W
10"	FFC1010W	FFC2010W	FFC8010W	FFC3010W
12"	FFC1012W	FFC2012W	FFC8012W	FFC3012W
24"	FFC1024W	FFC2024W	FFC8024W	FFC3024W

Corner Filler Panels



- The Corner Filler Panel is used to close a corner space between two base cabinets.

Width & Depth	Standing Ht.	Sitting Ht.	ADA Ht.
1" x 1"	CFC1001W	CFC2001W	CFC8001W
2" x 2"	CFC1002W	CFC2002W	CFC8002W
4" x 4"	CFC1004W	CFC2004W	CFC8004W
6" x 6"	CFC1006W	CFC2006W	CFC8006W

End Cover Panels



- End Cover Channels are fixed width and are used to close spaces between the back of a base cabinet and a wall.
- Filler panels can be ordered in 1" increments, up to 24" wide. Change the last two digits to the dimension required.

Width	Standing Ht.	Sitting Ht.	ADA Ht.	84" High
1"	ECC1001W	ECC2001W	ECC5001W	ECC3001W
2"	ECC1002W	ECC2002W	ECC5002W	ECC3002W
4"	ECC1004W	ECC2004W	ECC5004W	ECC3004W
7"	ECC1007W	ECC2007W	ECC5007W	ECC3007W
13"	ECC1013W	ECC2013W	ECC5013W	ECC3013W
14"	ECC1014W	ECC2014W	ECC5014W	ECC3014W
120mm	ECC100AW	ECC200AW	ECC500AW	ECC300AW

MISCELLANEOUS ITEMS

Front Wall Filler - 14" Deep



- The Wall Filler is used to close a space between two wall cabinets.
- Filler panels can be ordered in 1" increments, up to 24" wide. Change the last two digits to the dimension required.
- Depth dimensions are nominal.

Width	24" High	30" High	36" High	48" High
1"	WFP5301W	WFP6301W	WFP7301W	WFP8301W
2"	WFP5302W	WFP6302W	WFP7302W	WFP8302W
3"	WFP5303W	WFP6303W	WFP7303W	WFP8303W
4"	WFP5304W	WFP6304W	WFP7304W	WFP8304W
6"	WFP5306W	WFP6306W	WFP7306W	WFP8306W
8"	WFP5308W	WFP6308W	WFP7308W	WFP8308W
10"	WFP5310W	WFP6310W	WFP7310W	WFP8310W
12"	WFP5312W	WFP6312W	WFP7312W	WFP8312W
15"	WFP5315W	WFP6315W	WFP7315W	WFP8315W
18"	WFP5318W	WFP6318W	WFP7318W	WFP8318W
24"	WFP5324W	WFP6324W	WFP7324W	WFP8324W

Front Wall Fillers - 18" Deep



- The Wall Filler is used to close a space between two wall cabinets.
- Filler panels can be ordered in 1" increments, up to 24" wide. Change the last two digits to the dimension required.
- Depth dimensions are nominal.

Width	24" High	30" High	36" High	48" High
1"	WFP5201W	WFP6201W	WFP7201W	WFP8201W
2"	WFP5202W	WFP6202W	WFP7202W	WFP8202W
3"	WFP5203W	WFP6203W	WFP7203W	WFP8203W
4"	WFP5204W	WFP6204W	WFP7204W	WFP8204W
6"	WFP5206W	WFP6206W	WFP7206W	WFP8206W
8"	WFP5208W	WFP6208W	WFP7208W	WFP8208W
10"	WFP5210W	WFP6210W	WFP7210W	WFP8210W
12"	WFP5212W	WFP6212W	WFP7212W	WFP8212W
15"	WFP5215W	WFP6215W	WFP7215W	WFP8215W
18"	WFP5218W	WFP6218W	WFP7218W	WFP8218W
24"	WFP5224W	WFP6224W	WFP7224W	WFP8224W

Light Valances

- Light valances are to be fastened to the bottom of a wall cabinet. Available with left side, right side, or both returns.
- Light valances are 3" high with horizontal wood grain.

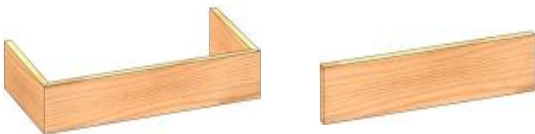

- Light valance returns are 7/8" shorter in depth than the standard depth of the cabinet.
- Front Only Light Valance to be fastened to the bottom of a wall cabinet.

Width	Right & Left Side Return		Front Only
	14" Return	18" Return	
18"	VPS3018W	VPS4018W	VPF1018W
24"	VPS3024W	VPS4024W	VPF1024W
30"	VPS3030W	VPS4030W	VPF1030W
36"	VPS3036W	VPS4036W	VPF1036W
42"	VPS3042W	VPS4042W	VPF1042W
48"	VPS3048W	VPS4048W	VPF1048W
60"	VPS3060W	VPS4060W	VPF1060W
72"	VPS3072W	VPS4072W	VPF1072W
96"	VPS3096W	VPS4096W	VPF1096W



- Left hand return Light Valance shown.
- Right hand return Light Valances are reverse of what is shown.

Width	Right Side Return		Left Side Return	
	14" Return	18" Return	14" Return	18" Return
18"	VPR3018W	VPR4018W	VPL3018W	VPL4018W
24"	VPR3024W	VPR4024W	VPL3024W	VPL4024W
30"	VPR3030W	VPR4030W	VPL3030W	VPL4030W
36"	VPR3036W	VPR4036W	VPL3036W	VPL4036W
42"	VPR3042W	VPR4042W	VPL3042W	VPL4042W
48"	VPR3048W	VPR4048W	VPL3048W	VPL4048W
60"	VPR3060W	VPR4060W	VPL3060W	VPL4060W
72"	VPR3072W	VPR4072W	VPL3072W	VPL4072W
96"	VPR3096W	VPR4096W	VPL3096W	VPL4096W

MISCELLANEOUS ITEMS

Front Rails



- Front Rails are commonly used to finish a space at a sitting area when a full frame apron is not required.
- Sides are not edge banded.

Width	2" High	3-3/4" High
15"	FRB0015W	FRA0015W
18"	FRB0018W	FRA0018W
24"	FRB0024W	FRA0024W
30"	FRB0030W	FRA0030W
36"	FRB0036W	FRA0036W
42"	FRB0042W	FRA0042W
48"	FRB0048W	FRA0048W
54"	FRB0054W	FRA0054W
60"	FRB0060W	FRA0060W
66"	FRB0066W	FRA0066W
72"	FRB0072W	FRA0072W
513mm	FRB000AW	FRA000AW
1000mm	FRB000BW	FRA000BW

Front Rail Service Covers



Width	Standing Height	Sitting Height	ADA Height
15"	SCP1015W	SCP2015W	SCP5015W
18"	SCP1018W	SCP2018W	SCP5018W
24"	SCP1024W	SCP2024W	SCP5024W
30"	SCP1030W	SCP2030W	SCP5030W
36"	SCP1036W	SCP2036W	SCP5036W
42"	SCP1042W	SCP2042W	SCP5042W
48"	SCP1048W	SCP2048W	SCP5048W
54"	SCP1054W	SCP2054W	SCP5054W
60"	SCP1060W	SCP2060W	SCP5060W
66"	SCP1066W	SCP2066W	SCP5066W
513mm	SCP100AW	SCP2100AW	SCP500AW
1000mm	SCP100BW	SCP200BW	SCP500BW

- Front Rail Service Cover panels are used to conceal open spaces and services where front rails are in place
- Attaches to adjacent cabinets and meets the underside of the work surface.
- Assembly includes single angles for attachment to adjacent cabinets. Upper panel is removable to allow access to the services. The lower panel stays fixed in order to apply covered base.

Apron Service Covers



Width	Standing Height	Sitting Height	ADA Height
15"	SCP3015W	SCP4015W	SCP6015W
18"	SCP3018W	SCP4018W	SCP6018W
24"	SCP3024W	SCP4024W	SCP6024W
30"	SCP3030W	SCP4030W	SCP6030W
36"	SCP3036W	SCP4036W	SCP6036W
42"	SCP3042W	SCP4042W	SCP6042W
48"	SCP3048W	SCP4048W	SCP6048W
54"	SCP3054W	SCP4054W	SCP6054W
60"	SCP3060W	SCP4060W	SCP6060W
66"	SCP3066W	SCP4066W	SCP6066W
513mm	SCP300AW	SCP400AW	SCP600AW
1000mm	SCP300BW	SCP400BW	SCP600BW

- Apron Service Cover panels are used to conceal open spaces and services below aprons.
- Attaches to adjacent cabinets and meets the underside of the bottom of the apron.
- Assembly includes single angles for attachment to adjacent cabinets. Upper panel is removable to allow access to the services. The lower panel stays fixed in order to apply covered base.

MISCELLANEOUS ITEMS

Apron Units - 22" Deep



Width	Plain Front	With Drawers	With Book Compartments	# of Drawers	# of Compartments
24"	AUC0124W	AUA0124W	AUB0124W	1	1
30"	AUC0130W	AUA0130W	AUB0130W	1	2
36"	AUC0136W	AUA0136W	AUB0136W	1	2
42"	AUC0142W	AUA0142W	AUB0142W	1	2
48"	AUC0148W	AUA0148W	AUB0148W	2	3
54"	AUC0154W	AUA0154W	AUB0154W	2	3
60"	AUC0160W	AUA0160W	AUB0160W	2	4
66"	AUC0166W	AUA0166W	AUB0166W	2	4
72"	AUC0172W	AUA0172W	AUB0172W	2	4
513mm	AUC010AW	AUA010AW	AUB010AW	1	1
1000mm	AUC010BW	AUA010BW	AUB010BW	1	2

- Aprons provide a work area from a seated position.
- Aprons are available plain or with drawers or with book compartments.
- Aprons are 3-3/4" high.
- Book compartments have an interior depth of 16".
- Actual depth 7/8" less than nominal.

Apron Units 28" Deep



Width	Plain Front	With Drawers	With Book Compartments	# of Drawers	# of Compartments
24"	AUC0424W	AUA0424W	AUB0424W	1	1
30"	AUC0430W	AUA0430W	AUB0430W	1	2
36"	AUC0436W	AUA0436W	AUB0436W	1	2
42"	AUC0442W	AUA0442W	AUB0442W	1	2
48"	AUC0448W	AUA0448W	AUB0448W	2	3
54"	AUC0454W	AUA0454W	AUB0454W	2	3
60"	AUC0460W	AUA0460W	AUB0460W	2	4
66"	AUC0466W	AUA0466W	AUB0466W	2	4
72"	AUC0472W	AUA0472W	AUB0472W	2	4
513mm	AUC040AW	AUA040AW	AUB040AW	1	1
1000mm	AUC040BW	AUA040BW	AUB040BW	1	2

- Aprons provide a work area from a seated position.
- Aprons are available plain, or with drawers or with book compartments.
- Aprons are 3-3/4" high.
- Book compartments have an interior depth of 16".
- Actual depth 7/8" less than nominal.

Arched Rail Apron Units



Width	22" Deep	28" Deep
24"	AUC0224W	AUC0324W
30"	AUC0230W	AUC0330W
36"	AUC0236W	AUC0336W
42"	AUC0242W	AUC0342W
48"	AUC0248W	AUC0348W
54"	AUC0254W	AUC0354W
60"	AUC0260W	AUC0360W
66"	AUC0266W	AUC0366W
72"	AUC0272W	AUC0372W
513mm	AUC020AW	AUC030AW
1000mm	AUC020BW	AUC030BW

- Arched aprons provide a work area from a seated position.
- 2" high front and rear rails.
- Actual depth 7/8" less than nominal.

MISCELLANEOUS ITEMS

Support Legs

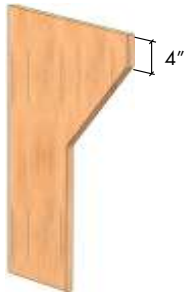

Depth	Standing Height	Sitting Height	ADA Height
28"	GLD1028W	GLD2028W	GLD3028W
29"	GLD1029W	GLD2029W	GLD3029W
34"	GLD1034W	GLD2034W	GLD3034W
35"	GLD1035W	GLD2035W	GLD3035W
46"	GLD1046W	GLD2046W	GLD3046W
52"	GLD1052W	GLD2052W	GLD3052W
58"	GLD1058W	GLD2058W	GLD3058W

- Legs are used to support Island counter tops or Aprons where base cabinets are not required.
- 3/4" thick.
- Nominal depths shown in chart.
- Actual depths 1-3/4" less than nominal.

Depth	Standing Height	Sitting Height	ADA Height
22"	GLA1022W	GLA2022W	GLA3022W
23"	GLA1023W	GLA2023W	GLA3023W
29"	GLA1029W	GLA2029W	GLA3029W
35"	GLA1035W	GLA2035W	GLA3035W

- Legs are used to support counter tops or Aprons where base cabinets are not required.
- Lower portion depth is half of overall depth.
- 3/4" thick.
- Nominal depths shown in chart.
- Actual depths 7/8" less than nominal.

Gable Legs



Depth	Standing Height	Sitting Height	ADA Height
22"	GLS1022W	GLS2022W	GLS3022W
23"	GLS1023W	GLS2023W	GLS3023W
29"	GLS1029W	GLS2029W	GLS3029W
35"	GLS1035W	GLS2035W	GLS3035W

- Gable Legs are used to support counter tops or Aprons where base cabinets are not required.
- Complete with finished wood cleats.
- 3/4" thick.
- Nominal depths shown in chart.
- Actual depths 7/8" less than nominal.

Table Legs



Height	Item Number
28-3/4"	3200000W
34-3/4"	3100000W
31-3/4"	3500000W

- Table Legs are used to support counter tops where base cabinets are not present.
- Leveling bolts and 4" high shoes are included.
- 2-1/8" wide by 2-1/8" deep.

MISCELLANEOUS ITEMS

Full Access Island Service Drops

Front View

Side View

Ceiling

1" 1"

Ceiling

6" Deep

Counter Top

Curb

HEIGHT

22-1/4"

Height	Item Number
68"	SDP1368W
73"	SDP1373W
78"	SDP1378W
90"	SDP1390W

- Use to carry utilities from the counter top up through the ceiling.
- Service Drop offers full height (from counter top to ceiling) access to services.
- Front panel attaches with Keku clips.

Full Access Wall Service Drops

Front View

Side View

Ceiling

1" 1"

Ceiling

4" Deep

Counter Top

Curb

HEIGHT

22-1/4"

Height	Item Number
68"	SDP1468W
73"	SDP1473W
78"	SDP1478W
90"	SDP1490W

- Use to carry utilities from the counter top up through the ceiling.
- Service Drop offers full height (from counter top to ceiling) access to services.
- Front panel attaches with Keku clips.
- Designed to fit on a 22" wide x 5" high x 4" deep curb.

MISCELLANEOUS ITEMS

Service Drops



Top View

Height	6" Deep		8" Deep	
	12" Wide	24" Wide	12" Wide	24" Wide
78"	SDP3078W	SDP4078W	SDP1078W	SDP2078W
90"	SDP3090W	SDP4090W	SDP1090W	SDP2090W

- Use to carry utilities from the counter top up through the ceiling.
- For Wall and Island applications.
- Each assembly consists of two 12" high fixed upper and lower panels and a removable center panel.
- 78" high service drop has 54" center lift off panel.
- 90" high service drop has 66" center lift off panel.

Sigma Flex™ Wood Shelves



Width	Wood Shelves					
	6" Depth	8" Depth	10" Depth	12" Depth	14" Deep	18" Deep
24"	FSH0624W	FSH0824W	FSH1024W	FSH1224W	FSH1424W	FSH1824W
30"	FSH0630W	FSH0830W	FSH1030W	FSH1230W	FSH1430W	FSH1830W
36"	FSH0636W	FSH0836W	FSH1036W	FSH1236W	FSH1436W	FSH1836W
42"	FSH0642W	FSH0842W	FSH1042W	FSH1242W	FSH1442W	FSH1842W
48"	FSH0648W	FSH0848W	FSH1048W	FSH1248W	FSH1448W	FSH1848W
54"	FSH0654W	FSH0854W	FSH1054W	FSH1254W	FSH1454W	FSH1854W
60"	FSH0660W	FSH0860W	FSH1060W	FSH1260W	FSH1460W	FSH1860W

- Shelf suitable for any Sigma Flex™ support structure or Sigma Cart™.
- Attach to shelf brackets with screws (screws not included).
- Nominal width.
- For wood shelving options see page N8.

Sigma Flex™ Shelf Retainer Rods



≤ 30" wide assemblies



>30" wide assemblies

Width	Wood Shelves		Retainer Rod Parts
	Powder Coated	Stainless Steel	
24"	PRR0024-FXW	SRR0024-FXW	1 rod & 2 turrets
30"	PRR0030-FXW	SRR0030-FXW	1 rod & 2 turrets
36"	PRR0036-FXW	SRR0036-FXW	1 rod & 3 turrets
42"	PRR0042-FXW	SRR0042-FXW	1 rod & 3 turrets
48"	PRR0048-FXW	SRR0048-FXW	1 rod & 3 turrets
54"	PRR0054-FXW	SRR0054-FXW	1 rod & 3 turrets
60"	PRR0060-FXW	SRR0060-FXW	1 rod & 3 turrets
66"	PRR0066-FXW	SRR0066-FXW	1 rod & 4 turrets

- 1" high retainer rod (5/16" dia.) Prevents articles from falling off the shelf.
- Available in stainless steel or powder coated stainless steel and can be added to existing shelves.
- Threaded turrets includes hardware for mounting to shelf (shelf must have holes drilled to accept turrets).
- Ships loose.
- FXW at the end of the part numbers represents an option code.

MISCELLANEOUS ITEMS

Wood Shelving Options



Height	Back Lip	Front Lip	Back & Front Lip
1"	ARW1	AFW1	ABW1
2"	ARW2	AFW2	ABW2
3"	ARW3	AFW3	ABW3
4"	ARW4	AFW4	ABW4

- Height of the lip is measured from the top of the shelf to the top of the lip. Lip is 3/4" thick.
- Shelves are 1" thick.

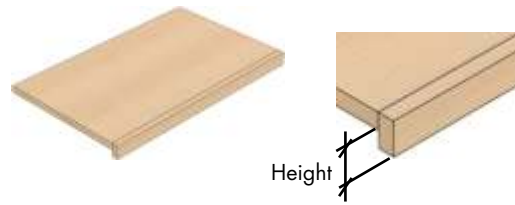

Height	Front Valance
1"	FV1
2"	FV2
3"	FV3
4"	FV4

- Height of the valance is measured from the bottom of the shelf to the bottom of the valance. Valance is 3/4" thick.
- Shelves are 1" thick.



Height	Bookends
4"	BE4
5"	BE5
6"	BE6

- Height of the bookends are measured from the top of the shelf to the top of the bookends. Bookends are 3/4" thick.
- Shelves are 1" thick.



Height	Bookends with Raised Lip at Back
4"	3BE4
5"	3BE5
6"	3BE6

- Height of the bookends and rear lip are measured from the top of the shelf to the top of the bookends or lip. Bookends and rear lip are 3/4" thick.
- Shelves are 1" thick.



Bookend with Raised Lip at Back Bookend Height	Raised Lip at Back		
	1"H	2"H	3"H
4"	BR41	BR42	BR43
5"	BR51	BR52	BR53
6"	BR61	BR62	BR63

- Height of the bookends and rear lip are measured from the top of the shelf to the top of the bookends or lip. Bookends and rear lip are 3/4" thick.
- Shelves are 1" thick.

MISCELLANEOUS ITEMS

Finished Back Panels



Width	Standing Height	Sitting Height	ADA Height
15"	FBP1015W	FBP2015W	FBP6015W
18"	FBP1018W	FBP2018W	FBP6018W
24"	FBP1024W	FBP2024W	FBP6024W
30"	FBP1030W	FBP2030W	FBP6030W
36"	FBP1036W	FBP2036W	FBP6036W
42"	FBP1042W	FBP2042W	FBP6042W
48"	FBP1048W	FBP2048W	FBP6048W

- Finished Back Panels are used to close off the back of a base cabinet when the back is in plain view.

Extended Finished Back Panels



Width	Standing Height			Sitting Height			ADA Height		
	6"Return	8"Return	12"Return	6"Return	8"Return	12"Return	6"Return	8"Return	12"Return
15"	FEA1506W	FEA1508W	FEA1512W	FEC1506W	FEC1508W	FEC1512W	FED1506W	FED1508W	FED1512W
18"	FEA1806W	FEA1808W	FEA1812W	FEC1806W	FEC1808W	FEC1812W	FED1806W	FED1808W	FED1812W
24"	FEA2406W	FEA2408W	FEA2412W	FEC2406W	FEC2408W	FEC2412W	FED2406W	FED2408W	FED2412W
30"	FEA3006W	FEA3008W	FEA3012W	FEC3006W	FEC3008W	FEC3012W	FED3006W	FED3008W	FED3012W
36"	FEA3606W	FEA3608W	FEA3612W	FEC3606W	FEC3608W	FEC3612W	FED3606W	FED3608W	FED3612W
42"	FEA4206W	FEA4208W	FEA4212W	FEC4206W	FEC4208W	FEC4212W	FED4206W	FED4208W	FED4212W
48"	FEA4806W	FEA4808W	FEA4812W	FEC4806W	FEC4808W	FEC4812W	FED4806W	FED4808W	FED4812W
60"	FEA6006W	FEA6008W	FEA6012W	FEC6006W	FEC6008W	FEC6012W	FED6006W	FED6008W	FED6012W
72"	FEA7206W	FEA7208W	FEA7212W	FEC7206W	FEC7208W	FEC7212W	FED7206W	FED7208W	FED7212W

- Extended Finished Back Panels are used to close off the back of a base cabinet when the back is in plain view.

Wall Cabinet Furring Panels



Width	14" Deep	18" Deep	22" Deep
18"	FPS1018W	FPS2018W	FPS3018W
24"	FPS1024W	FPS2024W	FPS3024W
30"	FPS1030W	FPS2030W	FPS3030W
36"	FPS1036W	FPS2036W	FPS3036W
42"	FPS1042W	FPS2042W	FPS3042W
48"	FPS1048W	FPS2048W	FPS3048W
60"	FPS1060W	FPS2060W	FPS3060W
72"	FPS1072W	FPS2072W	FPS3072W
96"	FPS1096W	FPS2096W	FPS3096W
1000mm	FPS100BW	FPS200BW	FPS300BW

- Wall Cabinet Furring Panels are used to close off the area between the top of a wall cabinet and the ceiling.
- Wall Cabinet Furring Panels are 7/8" shorter in depth than the standard depth of the cabinet.
- 24" high.
- Depth dimensions are nominal.

MISCELLANEOUS ITEMS

Double Sided Student Workstation

- Double Sided Student Workstations are designed to be used from both sides.
- Dimensions of 58" wide by 46" deep are available in sitting height (28-3/4") and standing height (34-3/4").
- Cabinet configurations are identical on each side of the assembly and are separated by 10" wide filler and include two pass through book compartments.
- Standing height workstations cabinets are 30" wide by 36" high by 18" deep.
- Sitting height workstations cabinets are 30" wide by 30" high by 18" deep.
- A variety of assemblies are available with different cabinet configurations. Please contact Mott for details.
- Counter tops are not included.

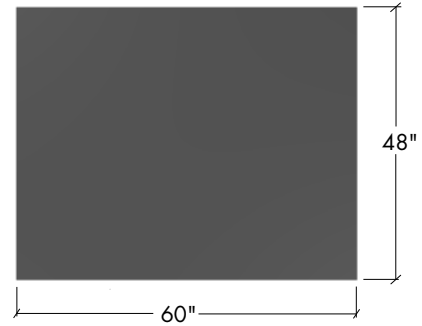

Required Counter Top Detail

Height	Item Number
28-3/4"	DSW0200W
34-3/4"	DSW0100W



Height	Item Number
28-3/4"	DSW0220W
34-3/4"	DSW0120W



Height	Item Number
28-3/4"	DSW0210W
34-3/4"	DSW0110W

MISCELLANEOUS ITEMS

Double Sided Student Workstation

- Double Sided Student Workstations are designed to be used from both sides.
- Dimensions of 58" wide by 46" deep are available in sitting height (28-3/4") and standing height (34-3/4").
- Cabinet configurations are identical on each side of the assembly and are separated by 10" wide filler and include two pass through book compartments.
- Standing height workstations cabinets are 30" wide by 36" high by 18" deep.
- Sitting height workstations cabinets are 30" wide by 30" high by 18" deep.
- A variety of assemblies are available with different cabinet configurations. Please contact Mott for details.
- Counter tops are not included.

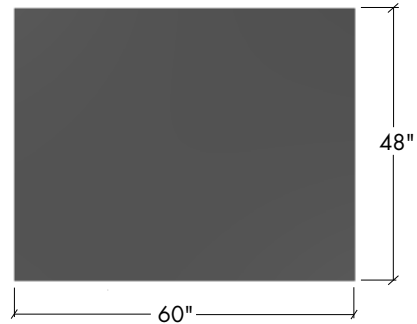

Required Counter Top Detail

Height	Item Number
28-3/4"	DSW0230W
34-3/4"	DSW0130W



Height	Item Number
28-3/4"	DSW0231W
34-3/4"	DSW0131W



Height	Item Number
28-3/4"	DSW0232W
34-3/4"	DSW0132W

MISCELLANEOUS ITEMS

Quad Student Workstation

- Quad Student Workstations are designed to be used from all sides.
- Dimensions of 58" wide by 58" deep are available in sitting height (28-3/4") and standing height (34-3/4").
- Cabinet configurations are identical on each side of the assembly and include accessible center space.
- Cabinet dimensions are 24" wide by 20" high by 15" deep.
- Quantity of four (one per side) 120volt, 20 amperage electrical receptacles are optional.
- A variety of assemblies are available with different cabinet configurations. Please contact Mott for details.
- Cabinets have a removable back in order to access a 19" wide by 10-1/4" high cutout in pedestal.
- Counter tops are not included.



Workstation with electrical receptacles shown

Height	Plain	With Electrical
28-3/4" High	QSW0200W	QSWE200W
34-3/4" High	QSW0100W	QSWE100W

Height	Plain	With Electrical
28-3/4" High	QSW0220W	QSWE220W
34-3/4" High	QSW0120W	QSWE120W

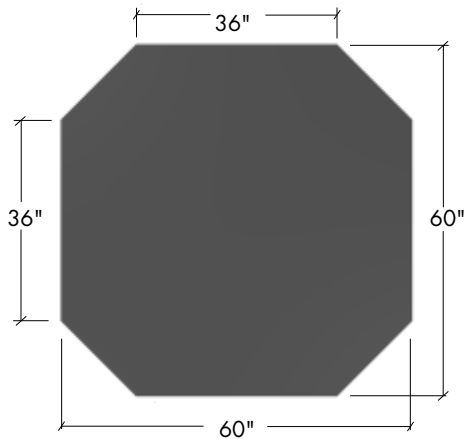

Required Counter Top Detail

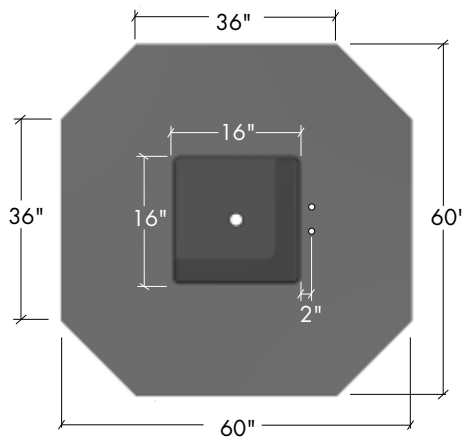

Required Counter with Sink Top Detail

- Maximum sink size is 16" x 16" with fixture holes located 2" from any side of the sink edge to center of fixture hole.

MISCELLANEOUS ITEMS

Quad Student Workstation

- Quad Student Workstations are designed to be used from all sides.
- Dimensions of 58" wide by 58" deep are available in sitting height (28-3/4") and standing height (34-3/4").
- Cabinet configurations are identical on each side of the assembly and include accessible center space.
- Cabinet dimensions are 24" wide by 20" high by 15" deep.
- Quantity of four (one per side) 120volt, 20 amperage electrical receptacles are optional.
- A variety of assemblies are available with different cabinet configurations. Please contact Mott for details.
- Cabinets have a removable back in order to access a 19" wide by 10-1/4" high cutout in pedestal.
- Counter tops are not included.



Workstation with electrical receptacles shown

Height	Plain	With Electrical
28-3/4" High	QSW0212W	QSWE212W
34-3/4" High	QSW0112W	QSWE112W

Height	Plain	With Electrical
28-3/4" High	QSW0211W	QSWE211W
34-3/4" High	QSW0110W	QSWE110W

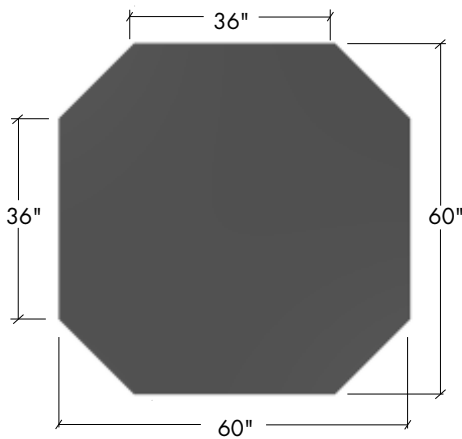

Required Counter Top Detail

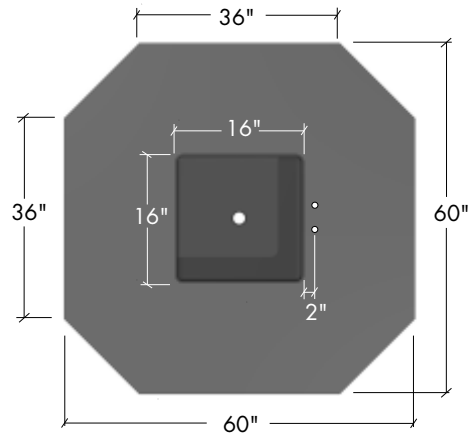

Required Counter with Sink Top Detail

- Maximum sink size is 16" x 16" with fixture holes located 2" from any side of the sink edge to center of fixture hole.

MISCELLANEOUS ITEMS

Two & Four Student Cabinet Storage Workstations

These are samples of some of the student storage workstations Mott offers. A variety of assemblies are available with different cabinet configurations in various dimensions. For additional information and help in planning contact Mott Manufacturing.



Demonstration Stations

These are samples of some of the demonstration workstations Mott offers. A variety of assemblies are available with different cabinet configurations in various dimensions. For additional information and help in planning contact Mott Manufacturing.



MISCELLANEOUS ITEMS OPTIONS

Option Code	Description
00	Modified door/drawer configuration
01	Full extension drawer runners
02	Label holders on all doors/drawers
03	Numeric or alpha identification disks on all doors/drawers (customer details required)
07	Cut-outs for electrical and/or plumbing services (customer drawing required)
09	Stainless steel waste flap
10	One fixed drawer divider per drawer (centered in drawer)
11	Multiple drawer dividers per drawer (customer drawing required)
12	Pull out writing board - all cold rolled steel*
13	Pull out writing board - cold rolled steel & high pressure laminate writing surface*
14	Ventilation grill in toe kick base
16	Ship handles not installed
17	Nylon levelers
19	Replaces standard drawer(s) with full width drawer(s) on 5" high apron
26	200 lbs full extension drawer runners
48	Keyboard tray (replaces drawer)
71	Toe kick - front & left side
79	Other customer specified base or toe kick
OLD	Actual Depth
PFE	Pull out writing board on full extension runners*
PW	Pre-wired (option code not to be used for fume hoods, customer details required)
SK	Skid item
S01	Full extension soft close drawer runners
S26	200lbs full extension soft close drawers runners