

SIGMA FLEX™

ADAPTABLE LABORATORY FURNITURE SOLUTIONS

The Sigma Flex™ System

Designed for the Lab of Tomorrow...

Laboratory technology changes today at an ever increasing rate. Today's challenge is to create an ideal workplace that has the potential to deliver future adaptability. Mott's Sigma Flex™ systems furniture successfully meets this challenge by delivering high levels of architectural style and reconfiguration potential, not only for today's lab, but also tomorrow's.

Mott's Sigma Flex™ system incorporates a standard core assembly from which upper and lower storage components and work surfaces are cantilevered. Further adaptability allows this system to be configured as an island assembly or a wall core assembly.

An extensive range of reconfiguration possibilities are available, allowing the laboratory designer to maximize laboratory productivity and space utilization through this stylish and ergonomically sound investment.

Mott's industry-leading flexible design and manufacturing capabilities allow the already very adaptable Sigma Flex™ system to be further modified to meet each laboratory's unique requirements through the incorporation of custom features.

What's more, Mott's Sigma Flex™ system is a proven practical solution. It can be installed and reconfigured with minimal down time, through the use of basic skills and without special tools.

For additional information and help in planning contact Mott Manufacturing.

SIGMA FLEX™

ADAPTABLE LABORATORY FURNITURE SOLUTIONS

Modular Support Structure Design

Each core system is fabricated from prime quality furniture grade cold rolled steel.

Support systems are a core and panel style support structure.

Core structures can be supported by anchoring to suitable flooring material or may be supported by structural table legs (outrigger legs).

Modular components are suitable for single faced wall core or double faced peninsula or island configurations.

Core assemblies have removable panels on all sides.

Modular Support Structure Features

Core or wall systems support work surfaces, under counter cabinets and overhead storage components.

Structural core systems may be configured for floor anchor alone, or additional support legs may be used if floor is not of sufficient strength for cantilever support.

The core system allows plumbing, electrical and other services to be installed using commonly available mounting systems.

Suspended cabinets can be supported using hook shaped rails attached near the front and rear of the cantilevered work surface. Cabinets can be added at any time and it is possible to remove and relocate a fully loaded cabinet to any position between legs.

All access panels can be fastened with a positive friction catch which snaps into place. The panel does not require adhesives to be attached. Panels are half width and it is possible to remove panels without removing suspended cabinets.

Upper storage cabinets are adjustable vertically and laterally and are removable.

Suspended cabinets can be relocated without disturbing the countertop.

The vertical height of table work surfaces, upper storage units and shelves can be adjusted in 1" increments without the use of special tools.

Material Gauges

- Riser uprights 16 gauge galvanized
- Upright connecting members 16 gauge
- Base cover 18 gauge
- Riser caps PVC, ABS or CRS
- Closure panels 18 gauge
- Floor anchor brackets 3" x 2" x 1/4" thick

SIGMA FLEX™

12" DEEP ISLAND CORES

Island Cores

Island Cores provide support for cantilevered upper and lower storage components and work surfaces and can accommodate major services. Island cores are 12" deep and offered in various widths and are available as lower or full height assemblies. Raised core assemblies are also available as lower or full height island cores.

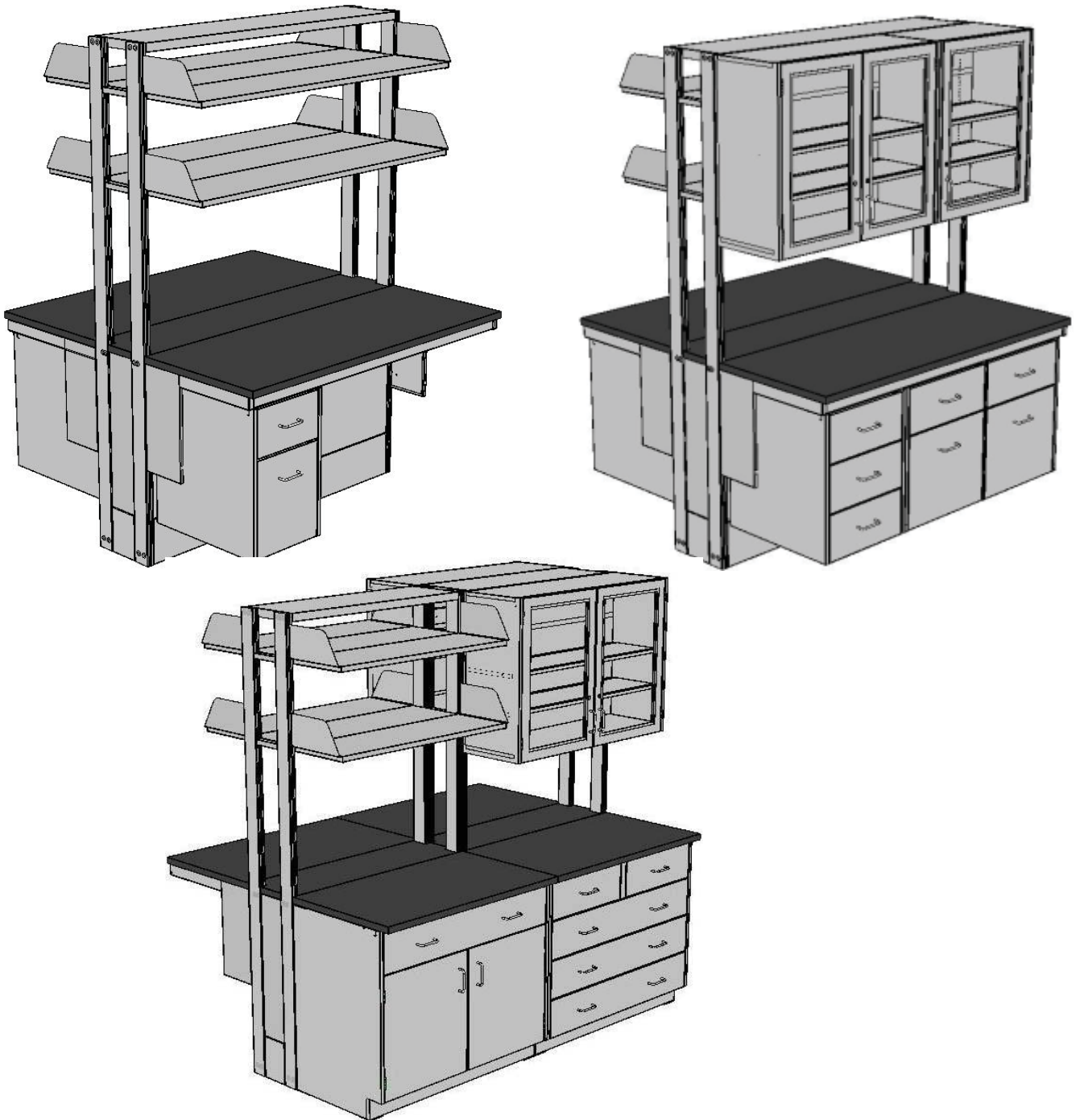

SIGMA FLEX™

12" DEEP ISLAND CORES

Parts List

- 1) Flex Island Core - Lower Frame End
- 2) Flex Island Core - Insert Panel
- 3) Left Hand Flex Post (Galvanized and Painted), Complete with Leveler
- 4) Right Hand Flex Post (Galvanized and Painted), Complete with Leveler
- 5) Flex Island Top Fixed Shelf
- 6) Flex Island Upright Frame (Galvanized)
Note: Lower Core Assembly is complete with one frame only. Raised Core Assembly complete with two frames (as shown).
- 7) Flex Island Upright - Lower End Filler
- 8) Flex Island Upright - Raised Core End Filler
- 9) Flex Bottom Filler
- 10) Flex Joining Plate (Galvanized)
- 11) Flex Core Base Angle
- 12) Flex Island Core - Raised Insert Panel
Note: Only On Raised Core Assembly
- 13) Internal Core Side Brace (Galvanized)

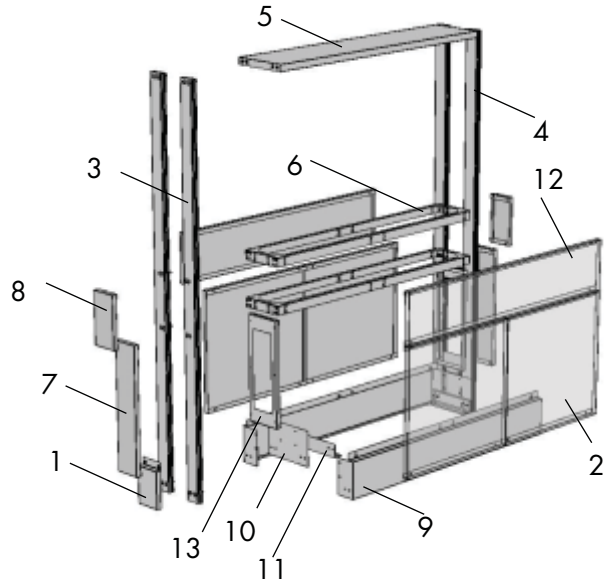

Load Ratings

Load Maximums

Maximum load ratings are live loads and include loads applied to top of work surface, including total weight of shelves and suspended cabinetry and other accessories. These capacities should be used as guidelines only. Please contact Mott Manufacturing for specific load requirements. Maximum load ratings are based on the load being evenly balanced on both sides. Individual component or assembly load ratings should not be exceeded for any surface.

Maximum Load Ratings

Modular Support Structure

- Top of Core 180lbs
- Top of Reagent Rack 180lbs
- Cantilevered Work surface 600lbs

Shelving

- 8" deep 180lbs
- 12" deep 180lbs
- 18" deep 130lbs
- 24" deep 100lbs

Suspended Cabinets

- Base Cabinets 300lbs
- Upper Cabinets 300lbs

Total Island Core Assembly

- Island Core 2820lbs

Includes two work surfaces at 600lbs each, and any combination of shelves, suspended upper cabinets (at their rated loads). Loads must be balanced both sides.

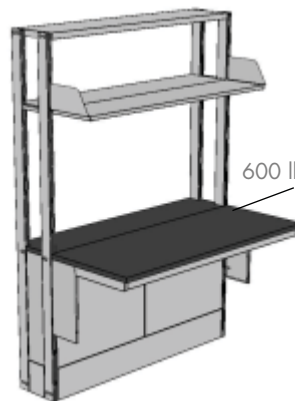

Island Core with Cantilever Table One Side

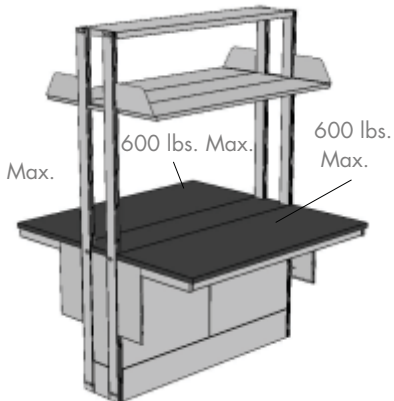

Island Core with Cantilever Table Double Sided

SIGMA FLEX™

12" DEEP ISLAND CORES ASSEMBLIES

Lower Island Cores

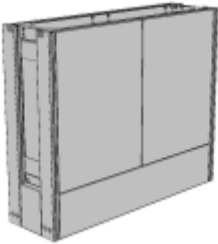

Width	Item Number
24"	FLS2024
30"	FLS2030
36"	FLS2036
42"	FLS2042
48"	FLS2048
54"	FLS2054
60"	FLS2060
66"	FLS2066
72"	FLS2072

- Core is 34-3/4" high and includes insert panels.
- Structure allows for plumbing, electrical and other services to be installed.
- Inserts are easy to remove, allowing for quick access to services.
- Simple to attach to adjacent cores.

Lower Island Raised Cores

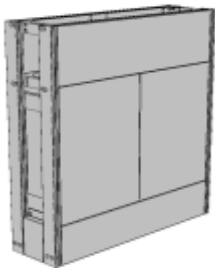

With Insert Panels

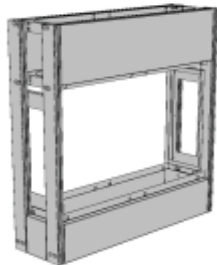

Without Insert Panels

Width	With Insert Panels	Without Insert Panels
24"	FLS4024	FLS4124
30"	FLS4030	FLS4130
36"	FLS4036	FLS4136
42"	FLS4042	FLS4142
48"	FLS4048	FLS4148
54"	FLS4054	FLS4154
60"	FLS4060	FLS4160
66"	FLS4066	FLS4166
72"	FLS4072	FLS4172

- Core is 45-3/4" high.
- Structure allows for plumbing, electrical and other services to be installed.
- Optional insert panels are easy to remove, allowing for quick access to services.
- Simple to attach to adjacent cores.

SIGMA FLEX™

12" DEEP ISLAND CORES ASSEMBLIES

Full Height Island Cores

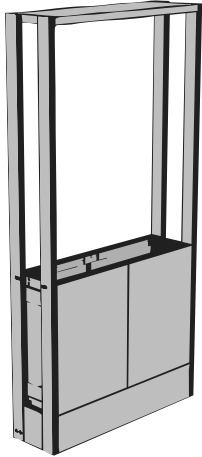

With Insert Panels

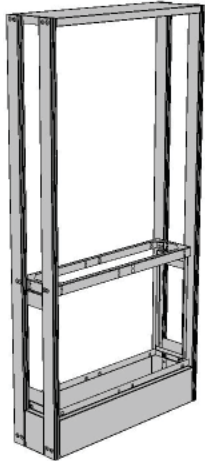

Without Insert Panels

Width	With Insert Panels	Without Insert Panels
24"	FLS1024	FLS1124
30"	FLS1030	FLS1130
36"	FLS1036	FLS1136
42"	FLS1042	FLS1142
48"	FLS1048	FLS1148
54"	FLS1054	FLS1154
60"	FLS1060	FLS1160
66"	FLS1066	FLS1166
72"	FLS1072	FLS1172

- One Piece Full Height assembly is 85" high and includes upper and lower island core.
- Lower core height is 34-3/4" high.
- Structure allows for plumbing, electrical and other services to be installed.
- Optional insert panels are easy to remove, allowing for quick access to services.
- Simple to attach to adjacent cores.

Full Height Island Raised Cores

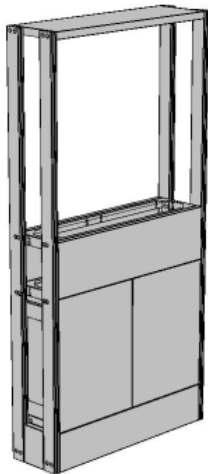

With Insert Panels

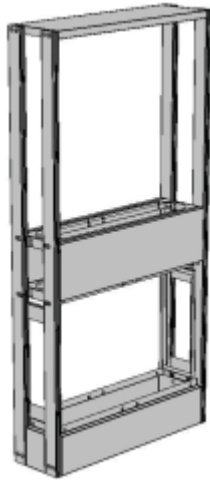

Without Insert Panels

Width	With Insert Panels	Without Insert Panels
24"	FLS3024	FLS3124
30"	FLS3030	FLS3130
36"	FLS3036	FLS3136
42"	FLS3042	FLS3142
48"	FLS3048	FLS3148
54"	FLS3054	FLS3154
60"	FLS3060	FLS3160
66"	FLS3066	FLS3166
72"	FLS3072	FLS3172

- One Piece Full Height Raised assembly is 85" high and includes upper and lower island core.
- Lower core height is 45-3/4" high.
- Structure allows for plumbing, electrical and other services to be installed.
- Optional insert panels are easy to remove, allowing for quick access to services.
- Simple to attach to adjacent cores.

SIGMA FLEX™

8-3/4" DEEP WALL CORES

Wall Cores

Wall Cores are designed for setting up around the edges of your lab by securing to the wall and floor. This provides support for cantilevered work surfaces and suspended cabinets. Wall cores are 8-3/4" deep and offered in various widths and are available as lower or full height assemblies. Raised core assemblies are also available as lower or full height wall cores.

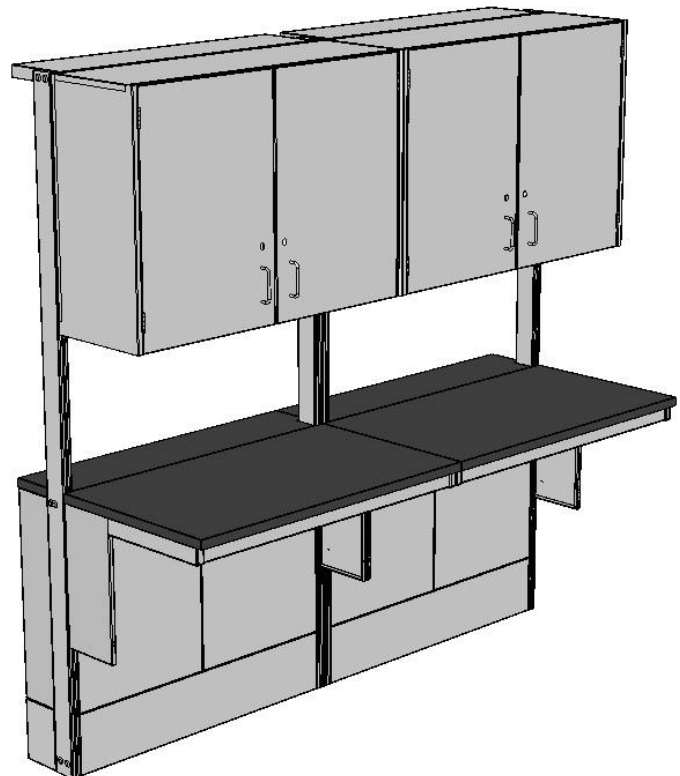
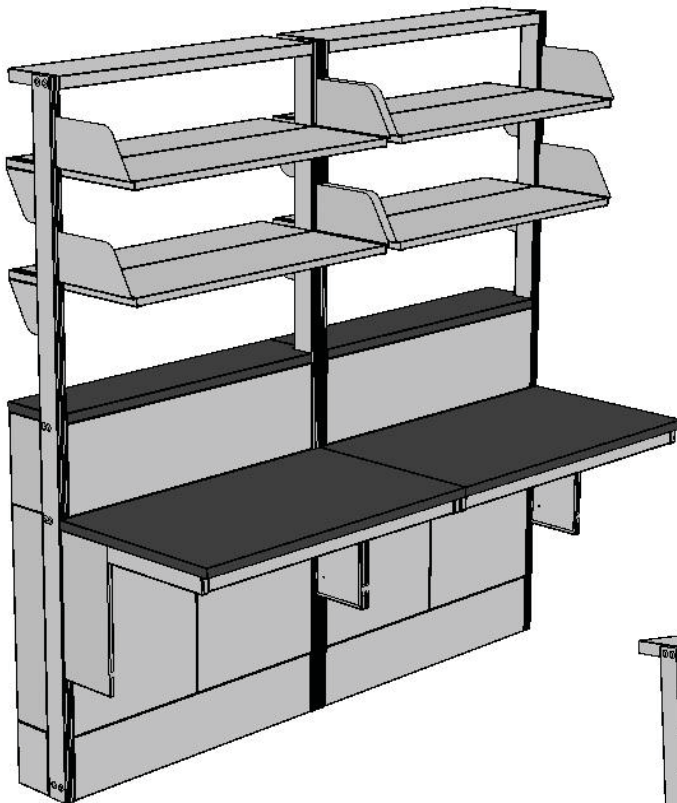

SIGMA FLEX™

8-3/4" DEEP WALL CORES

Parts List

- 1) Flex Wall Core - Lower Frame End
- 2) Flex Wall Core - Insert Panel
- 3) Left Hand Flex Post (Galvanized and Painted), Complete with Leveler
- 4) Right Hand Flex Post (Galvanized and Painted), Complete with Leveler
- 5) Flex Wall Top Fixed Shelf
- 6) Flex Wall Upright Frame (Galvanized)
Note - Lower Core Assembly is complete with one frame only. Raised Core Assembly complete with two frames (as shown).
- 7) Flex Wall Upright -Lower End Filler
- 8) Flex Wall Upright - Raised Core End Filler
- 9) Flex Bottom Filler
- 10) Flex Joining Plate (Galvanized)
- 11) Flex Core Base Angle
- 12) Flex Wall Core - Raised Insert Panel
Note: Only On Raised Wall Core Assembly

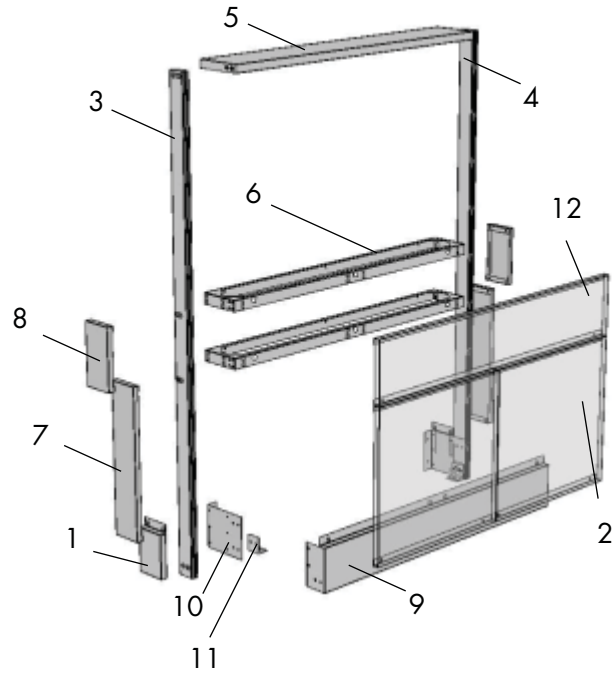

Load Ratings

Load Maximums

Maximum load ratings are live loads and include loads applied to top of work surface, including total weight of shelves and suspended cabinetry and other accessories. These capacities should be used as guidelines only. Please contact Mott Manufacturing for specific load requirements. Maximum load ratings are based on the load being evenly balanced on both sides. Individual component or assembly load ratings should not be exceeded for any surface.

Maximum Load Ratings

Modular Support Structure

- Top of Core 180lbs
- Top of Reagent Rack 180lbs
- Cantilevered Work surface 600lbs

Shelving

- 8" deep 180lbs
- 12" deep 180lbs
- 18" deep 130lbs
- 24" deep 100lbs

Suspended Cabinets

- Base Cabinets 300lbs
- Upper Cabinets 300lbs

Total Wall Core Assembly

- Wall Core 1680lbs

Includes one work surface at 600lbs, and any combination of shelves, suspended upper cabinets (at their rated loads).

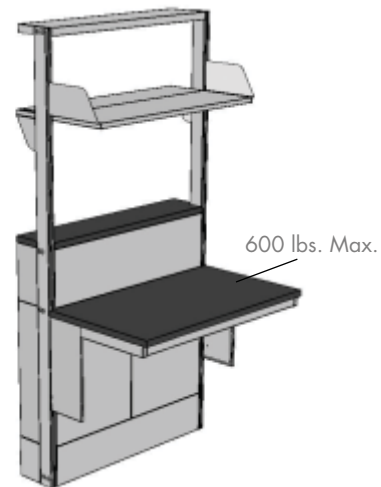

Wall Core with Cantilever Table One Side

SIGMA FLEX™

8-3/4" DEEP WALL CORES ASSEMBLIES

Lower Wall Cores

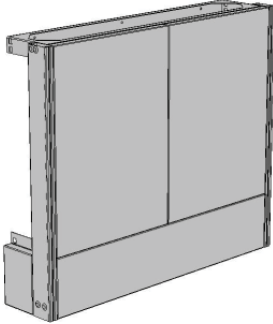

Width	Item Number
24"	FLW2024
30"	FLW2030
36"	FLW2036
42"	FLW2042
48"	FLW2048
54"	FLW2054
60"	FLW2060
66"	FLW2066
72"	FLW2072

- Core is 34-3/4" high and includes insert panels.
- Structure allows for plumbing, electrical and other services to be installed.
- Inserts are easy to remove, allowing for quick access to services.
- Simple to attach to adjacent cores.

Lower Wall Raised Cores

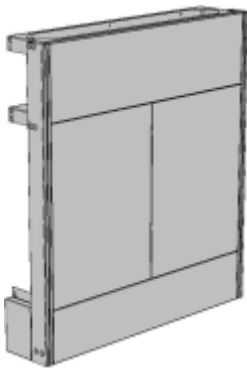

With Insert Panel

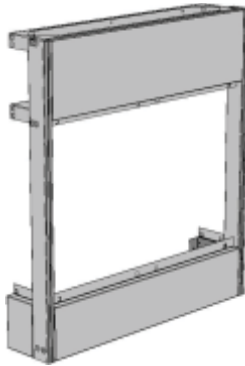

Without Insert Panel

Width	With Insert Panels	Without Insert Panels
24"	FLW4024	FLW4124
30"	FLW4030	FLW4130
36"	FLW4036	FLW4136
42"	FLW4042	FLW4142
48"	FLW4048	FLW4148
54"	FLW4054	FLW4154
60"	FLW4060	FLW4154
66"	FLW4066	FLW4166
72"	FLW4072	FLW4172

- Core is 45-3/4" high.
- Structure allows for plumbing, electrical and other services to be installed.
- Optional insert panels are easy to remove, allowing for quick access to services.
- Simple to attach to adjacent cores.

SIGMA FLEX™

8-3/4" DEEP WALL CORES ASSEMBLIES

Full Height Wall Cores

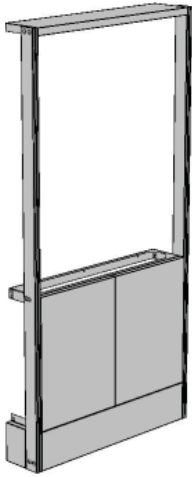

With Insert Panel

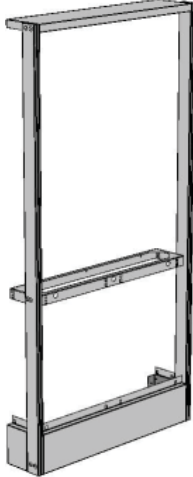

Without Insert Panel

Width	With Insert Panels	Without Insert Panels
24"	FLW1024	FLW1124
30"	FLW1030	FLW1130
36"	FLW1036	FLW1136
42"	FLW1042	FLW1142
48"	FLW1048	FLW1148
54"	FLW1054	FLW1154
60"	FLW1060	FLW1160
66"	FLW1066	FLW1166
72"	FLW1072	FLW1172

- One Piece Full Height assembly is 85" high and includes upper and lower island core.
- Lower core height is 34-3/4" high.
- Structure allows for plumbing, electrical and other services to be installed.
- Optional insert panels are easy to remove, allowing for quick access to services.
- Simple to attach to adjacent cores.

Full Height Wall Raised Cores

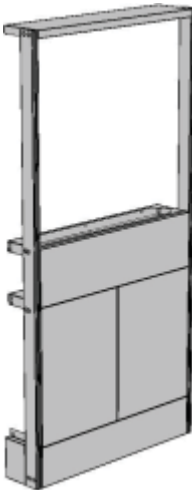

With Insert Panel

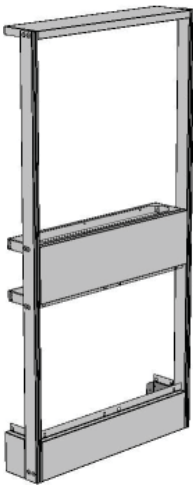

Without Insert Panel

Width	With Insert Panels	Without Insert Panels
24"	FLW3024	FLW3124
30"	FLW3030	FLW3130
36"	FLW3036	FLW3136
42"	FLW3042	FLW3142
48"	FLW3048	FLW3148
54"	FLW3054	FLW3154
60"	FLW3060	FLW3160
66"	FLW3066	FLW3166
72"	FLW3072	FLW3172

- One Piece Full Height Raised assembly is 85" high and includes upper and lower island core.
- Lower core height is 45-3/4" high.
- Structure allows for plumbing, electrical and other services to be installed.
- Insert panels are easy to remove, allowing for quick access to services.
- Simple to attach to adjacent cores.

SIGMA FLEX™

6" DEEP SINGLE CORES ISLAND FRAMES

Island Frame - Lower Core 28-3/4" High



With Full
Insert Panels

With Lower
Insert Panels

Without Insert
Panels

Lower Core 28-3/4" High			
Width	With Full Panels	With Lower Insert Panels	No Insert Panels
24"	SWF1224	SWF1024	SWF1124
30"	SWF1230	SWF1030	SWF1130
36"	SWF1236	SWF1036	SWF1136
42"	SWF1242	SWF1042	SWF1142
48"	SWF1248	SWF1048	SWF1148
54"	SWF1254	SWF1054	SWF1154
60"	SWF1260	SWF1060	SWF1160
66"	SWF1266	SWF1066	SWF1166
72"	SWF1272	SWF1072	SWF1172

- One piece full height assembly is 85" high by 6" deep (Ceiling extensions can be added to enclose an area up to 120" high).
- Accepts Sigma Flex™ shelves and above counter storage, adjustable on 1" increments.
- Optional insert cover panels are easy to remove, allowing for quick access to services.
- Panels are on both sides when ordered.

Island Frame - Lower Core 34-3/4" High



With Full
Insert Panels

With Lower
Insert Panels

Without Insert
Panels

Lower Core 34-3/4" High			
Width	With Full Panels	With Lower Insert Panels	No Insert Panels
24"	SWF2224	SWF2024	SWF2124
30"	SWF2230	SWF2030	SWF2130
36"	SWF2236	SWF2036	SWF2136
42"	SWF2242	SWF2042	SWF2142
48"	SWF2248	SWF2048	SWF2148
54"	SWF2254	SWF2054	SWF2154
60"	SWF2260	SWF2060	SWF2160
66"	SWF2266	SWF2066	SWF2166
72"	SWF2272	SWF2072	SWF2172

- One piece full height assembly is 85" high by 6" deep (Ceiling extensions can be added to enclose an area up to 120" high).
- Accepts Sigma Flex™ shelves and above counter storage, adjustable on 1" increments.
- Optional insert cover panels are easy to remove, allowing for quick access to services.
- Panels are on both sides when ordered.

Island Frame - Lower Core 45-3/4" High



With Full
Insert Panels

With Lower
Insert Panels

Without Insert
Panels

Lower Core 45-3/4" High			
Width	With Full Panels	With Lower Insert Panels	No Insert Panels
24"	SWF3224	SWF3024	SWF3124
30"	SWF3230	SWF3030	SWF3130
36"	SWF3236	SWF3036	SWF3136
42"	SWF3242	SWF3042	SWF3142
48"	SWF3248	SWF3048	SWF3148
54"	SWF3254	SWF3054	SWF3154
60"	SWF3260	SWF3060	SWF3160
66"	SWF3266	SWF3066	SWF3166
72"	SWF3272	SWF3072	SWF3172

- One piece full height assembly is 85" high by 6" deep (Ceiling extensions can be added to enclose an area up to 120" high).
- Accepts Sigma Flex™ shelves and above counter storage, adjustable on 1" increments.
- Optional insert cover panels are easy to remove, allowing for quick access to services.
- Panels are on both sides when ordered.

SIGMA FLEX™

COUNTERTOP UPRIGHTS

Countertop Uprights

Countertop Uprights makes the most of the work surface space. Island or wall Countertop Uprights assemblies can be mounted to any new or existing work surface and suspend shelving components (accommodates a maximum of 6 Sigma Flex™ shelves). Uprights are 49" high and are offered in island or wall mounted assemblies in various widths.

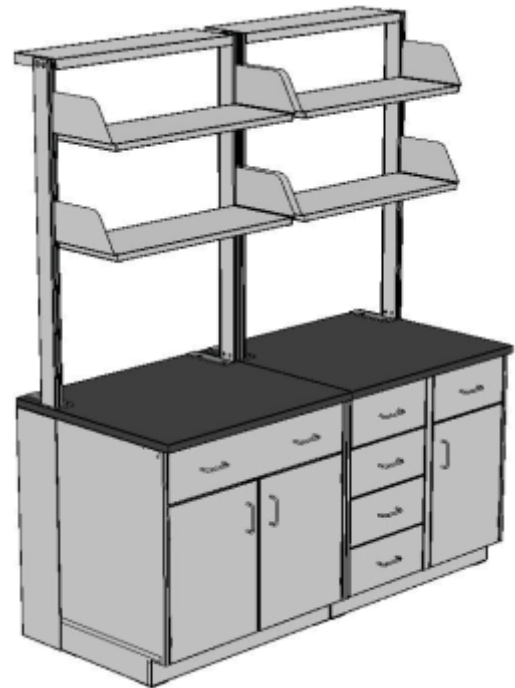
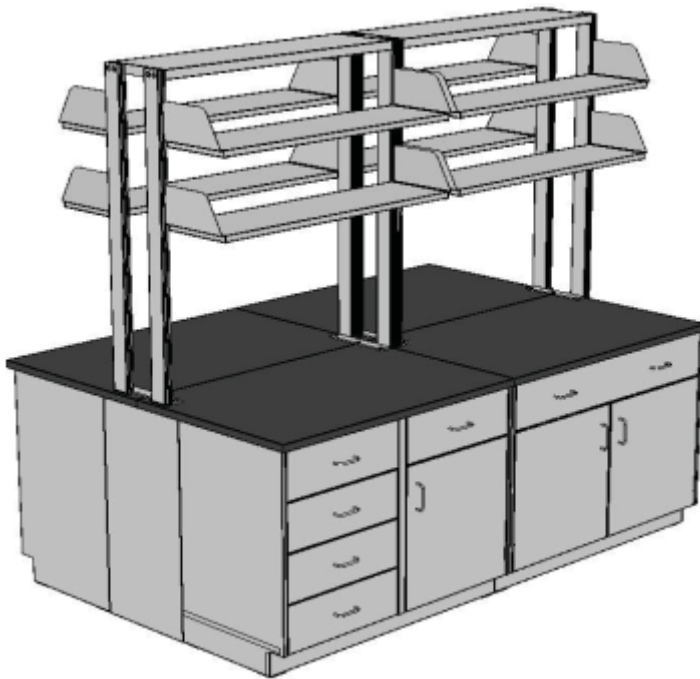

Parts List

- 1) Top Shelf
- 2) Flex Post with welded mounting plate



Countertop Island Upright

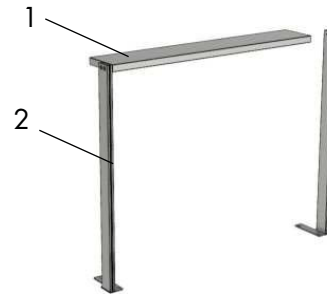

Countertop Wall Upright

SIGMA FLEX™

49" HIGH COUNTERTOP UPRIGHTS

Island Countertop Uprights

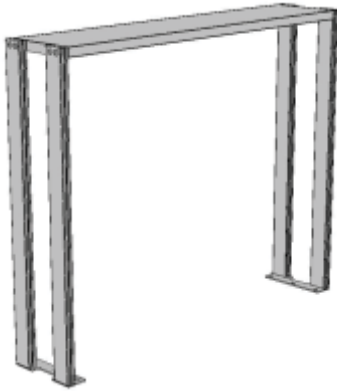

Width	Item Number
24"	BIU1024
30"	BIU1030
36"	BIU1036
42"	BIU1042
48"	BIU1048
54"	BIU1054
60"	BIU1060
66"	BIU1066
72"	BIU1072

- 49" high. 12" deep.
- Countertop upright assemblies can be mounted to any new or existing work surface.
- Accommodates a maximum of 6 Sigma Flex™ shelves, adjustable in 1" increments.
- Ensure work surface is of sufficient strength to support additional load.
- Mounting requires drilling bolt holes in work surface (3/8" countersunk bolts recommended for mounting are included).

Island Countertop Upright Cover Plates



Island Upright Cover Panels	
With Service Cut-outs	Without Service Cut-outs
BIC0001	BIC0000

Island Upright Double Sided Cover Panels	
With Service Cut-outs	Without Service Cut-outs
BIC0003	BIC0002

- For BIU Island Countertop Uprights only.
- Used to cover visible screws that install a BIU.
- Available with and without service cut-out.

Wall Countertop Uprights

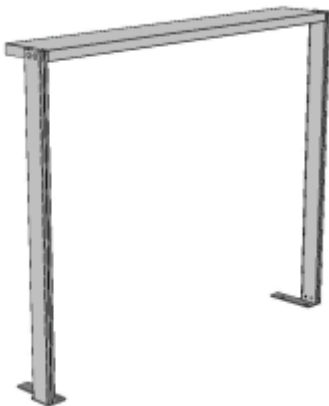

Width	Item Number
24"	BWU1024
30"	BWU1030
36"	BWU1036
42"	BWU1042
48"	BWU1048
54"	BWU1054
60"	BWU1060
66"	BWU1066
72"	BWU1072

- 49" high. 8-3/4" deep.
- Countertop upright assemblies can be mounted to any new or existing work surface.
- Accommodates a maximum of 3 Sigma Flex™ shelves, adjustable in 1" increments.
- Ensure work surface is of sufficient strength to support additional load.
- Mounting requires drilling bolt holes in work surface (3/8" countersunk bolts recommended for mounting are included).

Wall Countertop Upright Cover Plates



Item Number
BIC0004

- For BWU Wall Countertop Uprights only.
- Used to cover visible screws that install a BIU.

SIGMA FLEX™

3-1/4" DEEP SINGLE CORE FRAMES

Single Core Frames

Single Core Frames are designed to provide support for shelving when supported by adjacent base cabinets. Core Frames are 3-1/4" deep and offered in various widths and are available in full height assemblies with the option for electrical and data services in the lower panels.



Without Insert Panels

With Lower Insert Panels One Side Only

With Full Height Insert Panels One Side Only

Width	Without Insert Panels	With Lower Insert Panels	With Full Height Insert Panels
24"	SUF1124	SUF1024	SUF1224
30"	SUF1130	SUF1030	SUF1230
36"	SUF1136	SUF1036	SUF1236
42"	SUF1142	SUF1042	SUF1242
48"	SUF1148	SUF1048	SUF1248
54"	SUF1154	SUF1054	SUF1254
60"	SUF1160	SUF1060	SUF1260
66"	SUF1166	SUF1066	SUF1266
72"	SUF1172	SUF1072	SUF1272

- One piece full height assembly is 85" high by 3-1/4" deep.
- Used for island assemblies where single upright is needed and relies on adjacent fixed casework for support and suitable for most wall applications.
- Accepts Sigma Flex™ shelves that are adjustable in 1" increments.
- Work surfaces must be special ordered with notches to allow for uprights, or, panel work surfaces can be used to cover area between uprights.

Single Core Frame Supports

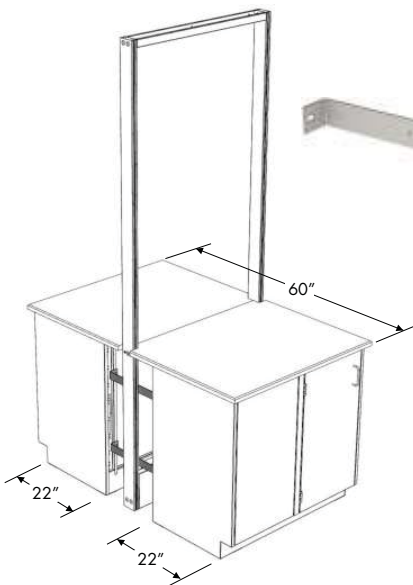

Item Number

SUF0000

- Single Core Frame Supports adds extra support for island assemblies. Comes with four supports.
- Attaches to interior of island core.
- Use with 22" deep base cabinets and supports 60" deep island work surfaces.

SIGMA FLEX™

1" DEEP WALL RAILS

Wall Rails

Wall Rail systems attaches to the wall to offer support structure when no services are required. Ensure your wall is of sufficient strength to support intended load (significant blocking required). Wall Rails are 1" deep which provides the benefit of no major reduction in lab floor space. Offered in various widths, and available in full height or upper assemblies and can be used with cantilevered work surfaces and shelves. Raised core assemblies are also available as lower or full height wall cores.

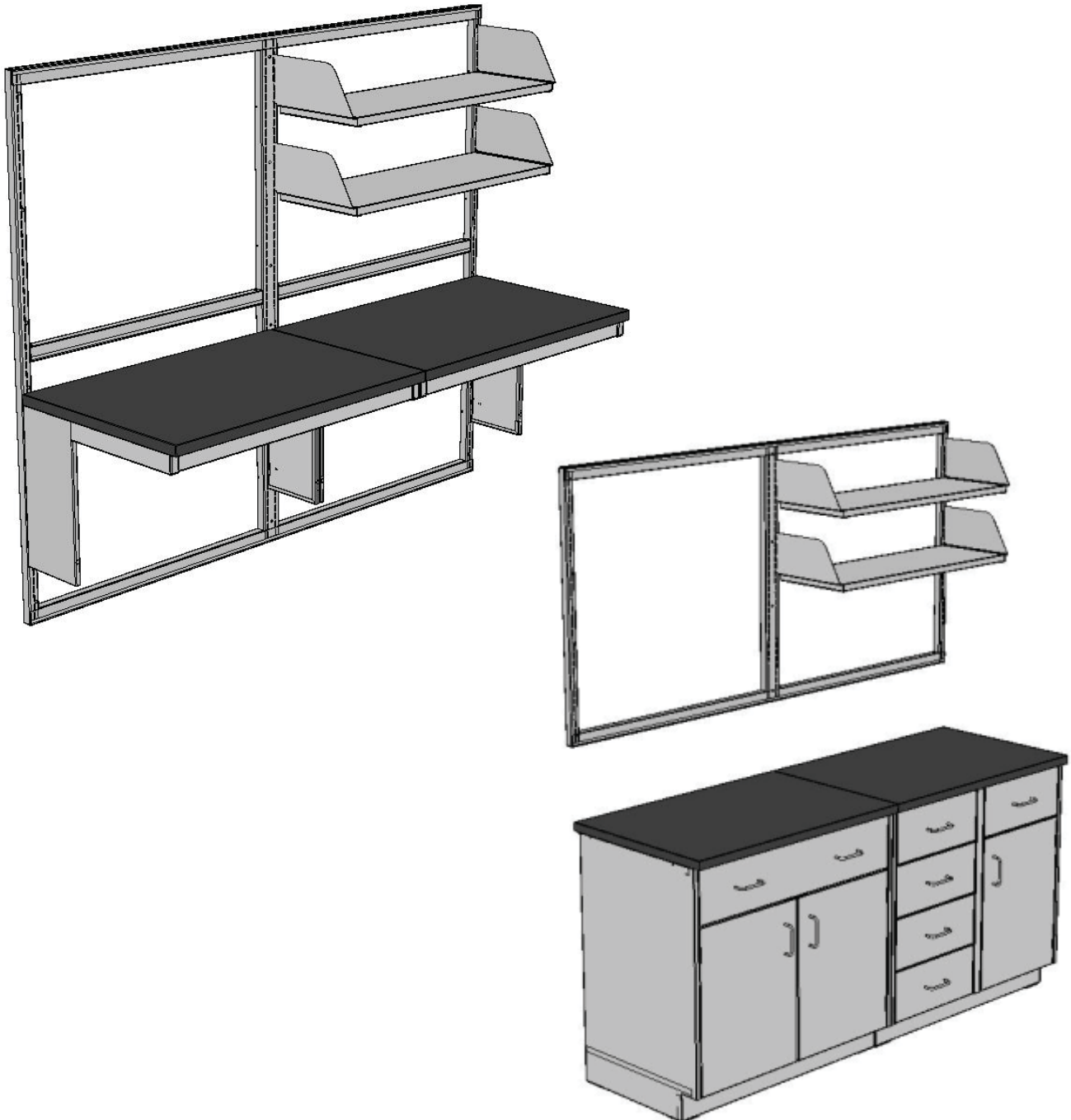

SIGMA FLEX™

1" DEEP WALL RAILS

Wall Blocking Guidelines

Over Counter Wall Rail System

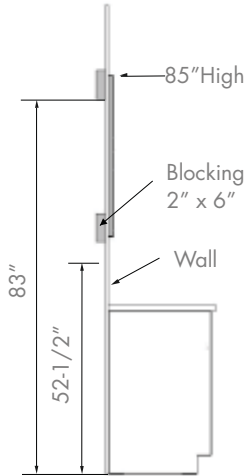

Under Counter Wall Rail System

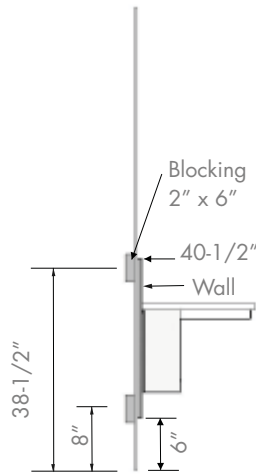

Full Height Wall Rail System

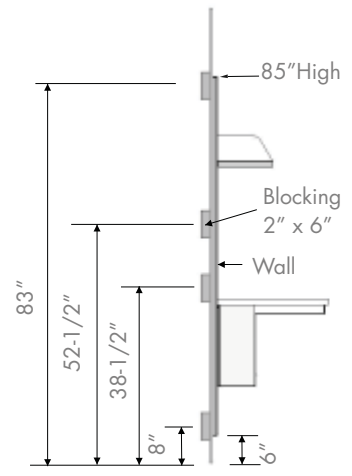

Major wall blocking is essential, do not set up Wall Rails on finished wall without blocking. If non-standard sizes are ordered, please contact Mott for blocking guidelines.

Load Ratings

Load Maximums

Maximum load ratings are live loads and include loads applied to top of work surface, including total weight of shelves. These capacities should be used as guidelines only. Please contact Mott Manufacturing for specific load requirements. Load ratings should not be exceeded for any surface.

Maximum Load Ratings

Modular Support Structure

- Suspended Upper Shelves 300lbs
- Cantilevered Work surface 400lbs

Shelving

- 8" deep 180lbs
- 12" deep 180lbs
- 18" deep 130lbs
- 24" deep 100lbs

Suspended Cabinets

- Base Cabinets 300lbs

Total Wall Core Assembly

- Wall Rail System 760lbs

Includes one work surface at 400lbs. each, and components (at their rated loads), not to exceed 360lbs.

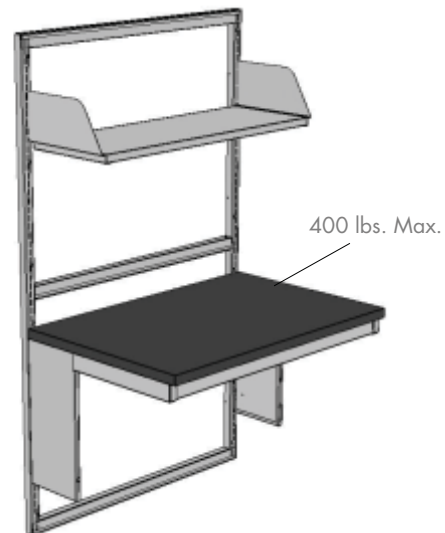

Wall Rail With Cantilevered Table

SIGMA FLEX™

1" DEEP WALL RAILS

Full Height Wall Rail Components

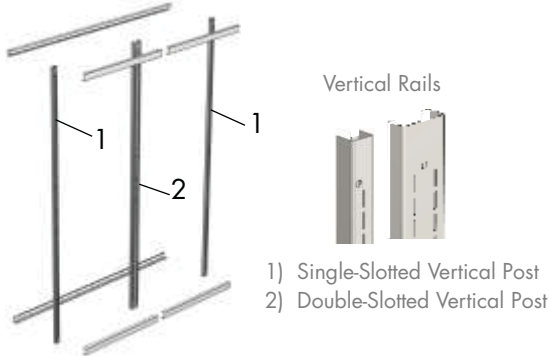

Full Height Vertical Rail	
Single Slotted	Double Slotted

- | | |
|---------|---------|
| WRV1079 | WRV1179 |
|---------|---------|
- Vertical Rail for full height assembly.
 - 79" high by 1" deep.
 - Order one double slotted and two single slotted vertical rails for each wall rail structure.
 - Rails are slotted in 1" increments.
 - Fastens to wall to give support structure where no services are required. Ensure wall is of sufficient strength to support intended load (significant blocking required).
 - Optional insert cover panels are available.
 - Accepts most Sigma Flex™ shelves and cantilevered work surfaces.

Half Height Wall Rail Components

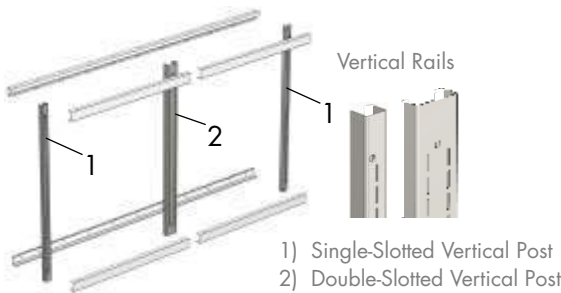

Half Height Vertical Rail	
Single Slotted	Double Slotted

- | | |
|---------|---------|
| WRV1034 | WRV1134 |
|---------|---------|
- Vertical Rail for above counter or below counter structure.
 - 34-1/2" high by 1" deep.
 - Order one double slotted and two single slotted vertical rails for each wall rail structure.
 - Rails are slotted in 1" increments.
 - Fastens to wall to give support structure where no services are required. Ensure wall is of sufficient strength to support intended load (significant blocking required).
 - Optional insert cover panels are available.
 - Accepts most Sigma Flex™ shelves and cantilevered work surfaces.

Horizontal Rail



Item Number

- | |
|---------|
| WRH1096 |
|---------|
- 8' long by 1" deep.
 - Upper and lower rails are included in part number.
 - Horizontal Rail provides a 6" adjustability for Double-Slotted Vertical Post.
 - Fastens to wall to give support structure where no services are required. Ensure wall is of sufficient strength to support intended load (significant blocking required).
 - Optional insert cover panels are available.

Horizontal Rail Cover



Width	Item Number
-------	-------------

- | | |
|-----|---------|
| 24" | WRC0024 |
| 30" | WRC0030 |
| 36" | WRC0036 |
| 42" | WRC0042 |
| 48" | WRC0048 |
| 54" | WRC0054 |
| 60" | WRC0060 |
| 66" | WRC0066 |
| 72" | WRC0072 |
- Fastens to Horizontal Rail.
 - One set of upper and lower covers are included in part number.
 - Dimensions are nominal.

SIGMA FLEX™

1" DEEP WALL RAILS

Full Height Upper Insert Cover Panel



30" wide unit shown

Width	Steel Insert Panel
24"	WRP2024
30"	WRP2030
36"	WRP2036
42"	WRP2042
48"	WRP2048
54"	WRP2054
60"	WRP2060
66"	WRP2066
72"	WRP2072

- For upper portion of full height wall rail only.
- Includes Middle Horizontal Rail.
- 44-1/2" high.
- Attaches easily with blind fasteners.

Half Height Lower Insert Cover Panel



30" wide unit shown

Width	Steel Insert Panel
24"	WRP1024
30"	WRP1030
36"	WRP1036
42"	WRP1042
48"	WRP1048
54"	WRP1054
60"	WRP1060
66"	WRP1066
72"	WRP1072

- For half height or lower portion of full height wall rail only.
- Includes Middle Horizontal Rail.
- 34-1/2" high.
- Attaches easily with blind fasteners.

Island Core Support Panel

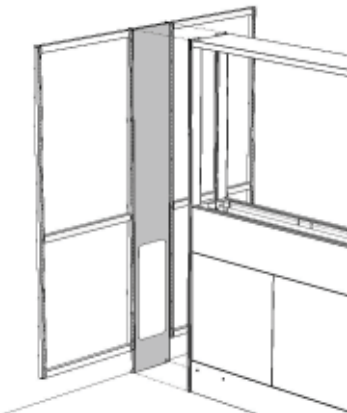

Item Number

CSP1012

- Use to expand an existing wall rail assembly to an island core.
- 85" high. 12" wide.
- Fastens to wall rail assembly with clips.

SIGMA FLEX™

CORE COMPONENTS

Lower Island And Wall End Filler

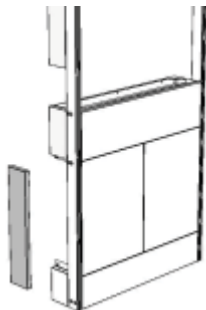

Item Number

FCM0000

- End fillers cover exposed ends of the 12" deep island and 8-3/4" deep wall core assemblies, providing a completed look to your Sigma Flex™ assembly.
- End fillers snap on for easy installation.

Raised Island And Wall Core End Filler



Item Number

FCT0000

- End fillers cover exposed ends of the 12" deep island and 8-3/4" deep wall raised core assemblies, providing a completed look to your Sigma Flex™ assembly.
- End fillers snap on for easy installation.

Upper Island Core End Fillers For 12" Deep Cores

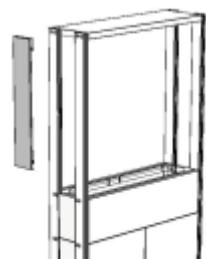

Height Item Number

24"	FCS2400
30"	FCS3000
36"	FCS3600
48"	FCS4800

- End fillers cover exposed ends of the 12" deep upper island core assembly, providing a completed look to your Sigma Flex™ assembly.
- Height size is based upon the height of the wall cabinet.
- End fillers have a lift off cover for easy installation.

Upper Wall Core End Fillers For 8-3/4" Deep Cores

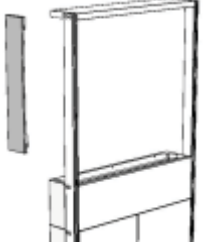

Height Item Number

24"	FCW2400
30"	FCW3000
36"	FCW3600
48"	FCW4800

- End fillers cover exposed ends of the 8-3/4" deep upper wall core assembly, providing a completed look to your Sigma Flex™ assembly.
- Height size is based upon the height of the wall cabinet.
- End fillers have a lift off cover for easy installation.

Strut Support



Item Number

VFC1000

- Strut type service line support carries additional support for plumbing or electrical service lines.
- Fastens to interior of island and wall cores.
- Strut height is 26-3/4" high.
- Strut is 1-5/8" X 13/16".

6" Deep Single Core - End Cover Filler



Item Number

FCM1000

- End cover panels cover exposed ends of the 6" deep island assemblies, providing a completed look to your Sigma Flex™ assembly.
- End cover panels screw on for easy installation.

Double Work Surface Filler Inserts

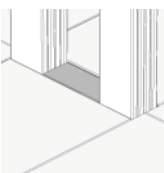

Core Type	1" Thick	1-1/4" Thick
Island Core	FDSW001	FDSW002
Wall Core	FDWW001	FDWW002

- Island and wall core double work surface fillers cover the exposed portion of the 12" deep island core assembly and the 8-3/4" deep wall core assembly, providing a completed look to your Sigma Flex™ assembly.
- For use when reagent core tops are not notched for posts and rectangular work surfaces are required.
- End fillers clip in for easy installation.

Single Work Surface Filler Inserts



Core Type	1" Thick	1-1/4" Thick
Island Core	FSSW001	FSSW002
Wall Core	FSWW001	FSWW002

- Island and wall core single work surface fillers cover the exposed portion of the 12" deep island core assembly and the 8-3/4" deep wall core assembly, providing a completed look to your Sigma Flex™ assembly.
- For use when reagent core tops are not notched for posts and rectangular work surfaces are required.
- End fillers clip in for easy installation.

SIGMA FLEX™

CORE COMPONENTS

Sigma Flex™ Wall Cabinet Hanger Rails

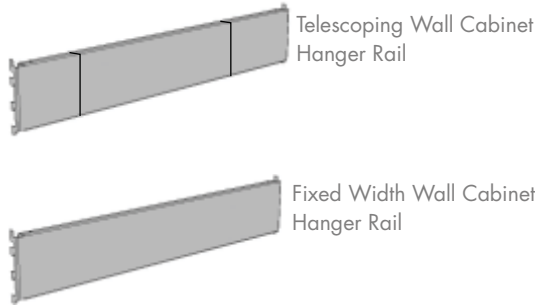

Width	Telescoping Rail	Fixed Width Rail
24"	TWR0024	FWR0024
30"	TWR0030	FWR0030
36"	TWR0036	FWR0036
42"	TWR0042	FWR0042
48"	TWR0048	FWR0048
54"	TWR0054	FWR0054
60"	TWR0060	FWR0060
72"	TWR0072	FWR0072

- Sigma Flex™ Wall Cabinet Hanger Rails are required to hang above-counter storage cabinets on to Sigma Flex™ systems.
- Order rails to match width of support structure frame (Telescoping Rails are not suitable for cabinets smaller than 24" wide). If ordering rails larger than the wall cabinet, two rails are required for support.
- Telescoping Rail is adjustable up to 5".
- Wall cabinets must be ordered with option code "FR" to suspend from Sigma Flex™ and Sigma Cart™ products. See wall cabinet section to order cabinets.

Island Service Drop For 12" Deep Cores

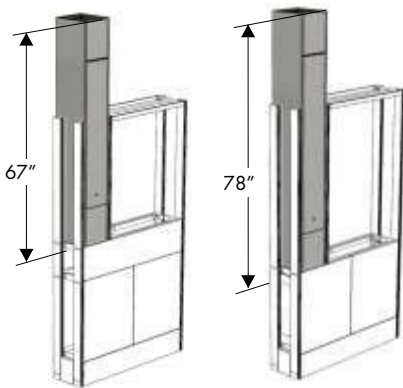

Full Height Island Raised Core Full Height Island Core

Option Code

R1

- Use this option code when ordering Sigma Flex™ 12" deep Island Core assemblies.
- For new installations only.
- For use to run utilities and services on Sigma Flex™ 12" deep island cores and counter top uprights.
- Additional uprights allow for center shelves.
- Center shelves must be ordered 12" less in width to accommodate service drop.
- Detachable inserts are easy to remove, allowing access to services on both sides of service drop.
- Wall cabinets cannot be added with option R1 due to load capabilities.
- Full Height Island Raised Core with R1 option is a standard height of 67".
- Full Height Island Core with R1 option is a standard height of 78".
- Custom heights are available, please specify when ordering.

Wall Service Drop For 8-3/4" Deep Cores

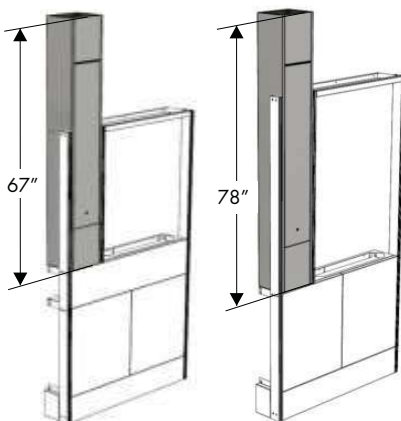

Full Height Wall Core with Left Hand Service Drop shown Full Height Wall Raised Core with Left Hand Service Drop shown

Right Hand Option Code Left Hand Option Code

R3

R4

- Use this option code when ordering Sigma Flex™ 8-3/4" deep Wall Core assemblies.
- For new installations only.
- For use to run utilities and services on Sigma Flex™ 8-3/4" deep wall cores and counter top uprights.
- Additional uprights allow for center shelves.
- Center shelves must be ordered 12" less in width to accommodate service drop.
- Detachable insert are easy to remove, allowing access to services.
- Wall cabinets cannot be added with option R3 or R4 due to load capabilities.
- Full Height Wall Raised Core with R3 and R4 option is a standard height of 67".
- Full Height Wall Core with R3 and R4 option is a standard height of 78".
- Custom heights are available, please specify when ordering.

SIGMA FLEX™

CORE COMPONENTS

Corner Island Service Pillars For 12" Deep Cores

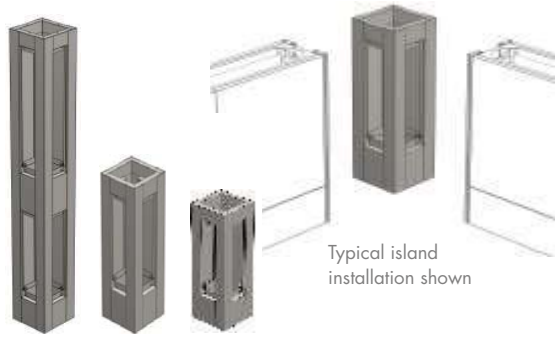

Pillars For Core	Item Number
28-3/4" Core	CPS0000
34-3/4" Core	CPS1000
45-3/4" Core	CPS2000
85" Core	CPS3000

- For use to run utilities and services and goes around corners for island cores.
- Detachable inserts are easy to remove, allowing access to services.
- Pillars bolt to adjacent cores.
- 12" wide by 12" deep. Shipped assembled.
- Panels supplied on 2 sides only.

Corner Wall Service Pillars For 8-3/4" Deep Cores

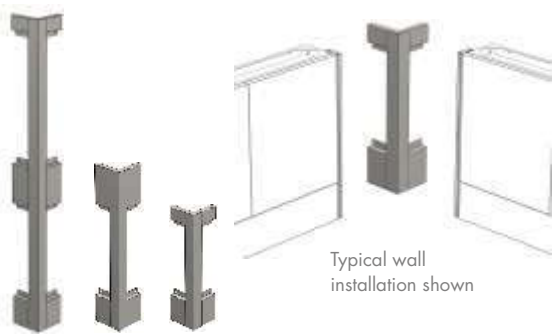

Pillars For Core	Item Number
28-3/4" Core	CPW0000
34-3/4" Core	CPW1000
45-3/4" Core	CPW2000
85" Core	CPW3000

- For use to run utilities and services and goes around corners for wall cores.
- Detachable inserts are easy to remove, allowing access to services.
- 8-3/4" wide by 8-3/4" deep. Shipped assembled.
- No panels supplied.

Peninsula Service Pillars For 8-3/4" Deep Cores



Pillars For Core	Item Number
28-3/4" Core	CPP0000
34-3/4" Core	CPP1000
45-3/4" Core	CPP2000
85" Core	CPP3000

- For use to run utilities and services on peninsulas and goes around corners for island and wall cores.
- Detachable inserts are easy to remove, allowing access to services.
- 12" wide by 8-3/4" deep. Shipped assembled.
- No panels supplied.

Corner Island Service Pillars For 6" Deep Cores



Pillars For Core	Item Number
28-3/4" Core	CPS0006
34-3/4" Core	CPS1006
45-3/4" Core	CPS2006
85" Core	CPS3006

- For use to run utilities and services and goes around corners for island cores.
- Detachable inserts are easy to remove, allowing access to services.
- Pillars bolt to adjacent cores.
- 6" wide by 6" deep. Shipped assembled.
- Panels supplied on 2 sides only.

SIGMA FLEX™

TABLE FRAMES

Cantilevered Table Frames

Cantilevered Table Frames are manufactured to fasten to Sigma Flex™ support assemblies, providing support for suspended cabinets.

Cantilevered Table Frames - 23" Deep



Width	Item Number
24"	CCS0024
30"	CCS0030
36"	CCS0036
42"	CCS0042
48"	CCS0048
54"	CCS0054
60"	CCS0060
66"	CCS0066
72"	CCS0072

- Table frame is 23" deep by 18" high and to be used with 24" deep work surface (work surface not included).
- 23" deep table frame will hold cabinets with a total combined width of 3" less than the table frame.
- Complete with hanging rails to suspend casework.
- Can be vertically adjusted in 1" increments.
- Includes a surface leveling system.
- Space at the rear edge of frame to allow for cable drop
- Consult Mott Manufacturing if supporting cantilevered frame on "L" shapes wider than 8' or any straight island 6" core.

Cantilevered Table Frames - 29" Deep



Width	Item Number
24"	CCS1024
30"	CCS1030
36"	CCS1036
42"	CCS1042
48"	CCS1048
54"	CCS1054
60"	CCS1060
66"	CCS1066
72"	CCS1072

- Table frame is 29" deep by 18" high and to be used with 30" deep work surface (work surface not included).
- 29" deep table frame will hold cabinets with a total combined width equal to the width of the table frame.
- Complete with hanging rails to suspend casework.
- Can be vertically adjusted in 1" increments.
- Includes a surface leveling system.
- Space at the rear edge of frame to allow for cable drop.
- Consult Mott Manufacturing if supporting cantilevered frame on "L" shapes wider than 8' or any straight island 6" core.

Cantilevered Corner Table Support Frames



Core Width	23" Deep	29" Deep
36" x 36"	CCS2336	CCS2936
48" x 48"	CCS2348	CCS2948

- Table frame available 23" or 29" deep by 18" high (work surface not included).
- Includes rear support bracket.
- Table frame cannot suspend casework.
- Can be vertically adjusted in 1" increments.
- Includes a surface leveling system.
- Space at the rear edge of frame to allow for cable drop.

SIGMA FLEX™

SHELF COMPONENTS

Shelves

Sigma Flex™ is designed and manufactured to accommodate upper storage cabinets and shelving. Shelves are adjustable in height and available in various widths for island and wall cores.

Outer and Top Shelves

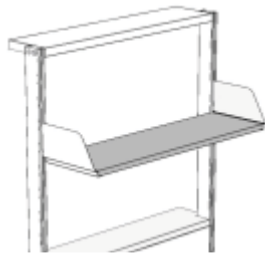

Steel Shelves						
Width	6"Depth	8"Depth	10"Depth	12"Depth	14" Deep	18" Deep
24"	FSH0624	FSH0824	FSH1024	FSH1224	FSH1424	FSH1824
30"	FSH0630	FSH0830	FSH1030	FSH1230	FSH1430	FSH1830
36"	FSH0636	FSH0836	FSH1036	FSH1236	FSH1436	FSH1836
42"	FSH0642	FSH0842	FSH1042	FSH1242	FSH1442	FSH1842
48"	FSH0648	FSH0848	FSH1048	FSH1248	FSH1448	FSH1848
54"	FSH0654	FSH0854	FSH1054	FSH1254	FSH1454	FSH1854
60"	FSH0660	FSH0860	FSH1060	FSH1260	FSH1460	FSH1860
66"	FSH0666	FSH0866	FSH1066	FSH1266	FSH1466	FSH1866
72"	FSH0672	FSH0872	FSH1072	FSH1272	FSH1472	FSH1872

Wood Shelves						
Width	6"Depth	8"Depth	10"Depth	12"Depth	14" Deep	18" Deep
24"	FSH0624W	FSH0824W	FSH1024W	FSH1224W	FSH1424W	FSH1824W
30"	FSH0630W	FSH0830W	FSH1030W	FSH1230W	FSH1430W	FSH1830W
36"	FSH0636W	FSH0836W	FSH1036W	FSH1236W	FSH1436W	FSH1836W
42"	FSH0642W	FSH0842W	FSH1042W	FSH1242W	FSH1442W	FSH1842W
48"	FSH0648W	FSH0848W	FSH1048W	FSH1248W	FSH1448W	FSH1848W
54"	FSH0654W	FSH0854W	FSH1054W	FSH1254W	FSH1454W	FSH1854W
60"	FSH0660W	FSH0860W	FSH1060W	FSH1260W	FSH1460W	FSH1860W

- . Shelf suitable for any Sigma Flex™ or Sigma Cart™.
- . Attach to shelf brackets with screws (screws not included).
- . Nominal width.
- . To order Under Mount Shelf Task Light refer to Steel Miscellaneous Section.
- . Add option code EW for exact width.

Shelf Retainer Rods

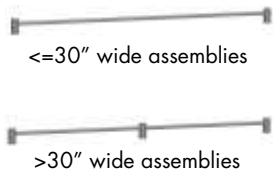

Width	Steel Shelves		Wood Shelves		Retainer Rod Sizes Measured on Centers
	Powder Coated	Stainless Steel	Powder Coated	Stainless Steel	
24"	PRR0024-FX	SRR0024-FX	PRR0024-FXW	SRR0024-FXW	1 rod & 2 turrets
30"	PRR0030-FX	SRR0030-FX	PRR0030-FXW	SRR0030-FXW	1 rod & 2 turrets
36"	PRR0036-FX	SRR0036-FX	PRR0036-FXW	SRR0036-FXW	1 rod & 3 turrets
42"	PRR0042-FX	SRR0042-FX	PRR0042-FXW	SRR0042-FXW	1 rod & 3 turrets
48"	PRR0048-FX	SRR0048-FX	PRR0048-FXW	SRR0048-FXW	1 rod & 3 turrets
54"	PRR0054-FX	SRR0054-FX	PRR0054-FXW	SRR0054-FXW	1 rod & 3 turrets
60"	PRR0060-FX	SRR0060-FX	PRR0060-FXW	SRR0060-FXW	1 rod & 3 turrets
66"	PRR0066-FX	SRR0066-FX	PRR0066-FXW	SRR0066-FXW	1 rod & 4 turrets
72"	PRR0072-FX	SRR0072-FX	-	-	1 rod & 4 turrets

- . 1" high retainer rod (5/16" dia.) Prevents articles from falling off the shelf.
- . Retainer rods are measured on centers.
- . Can be added to existing shelves.
- . Available in stainless steel or powder coated stainless steel.
- . Threaded turrets includes hardware for mounting to shelf (shelf must have holes drilled to accept turrets).
- . Ships loose.
- . FX and FXW at the end of the part numbers represent option codes.

SIGMA FLEX™

SHELF COMPONENTS

Steel Shelf Angles

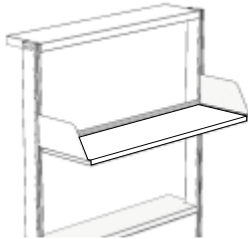

- Shelf with rear angle is suitable for any Sigma Flex™ structure or Sigma Cart™.
- Use option codes below to add angles to steel shelves only:
 - AR (Rear Shelf Angle welded to shelf)
 - AF (Front Shelf Angle welded to shelf)
 - AB (Rear and Front Shelf Angle welded to shelf)

Wood Shelving Options

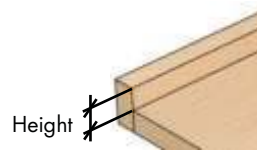

Height	Back Lip	Front Lip	Back & Front Lip
1"	ARW1	AFW1	ABW1
2"	ARW2	AFW2	ABW2
3"	ARW3	AFW3	ABW3
4"	ARW4	AFW4	ABW4

- Height of the lip is measured from the top of the shelf to the top of the lip. Lip is 3/4" thick.
- Shelves are 1" thick.

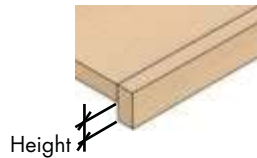

Height	Front Valance
1"	FV1
2"	FV2
3"	FV3
4"	FV4

- Height of the valance is measured from the bottom of the shelf to the bottom of the valance. Valance is 3/4" thick.
- Shelves are 1" thick.

Island Center Shelves For 12" Deep Cores

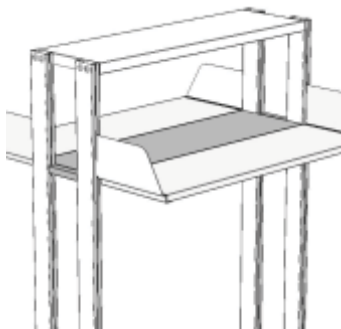

Width	Steel Shelves	Wood Shelves
24"	FSC1224	FSC1224W
30"	FSC1230	FSC1230W
36"	FSC1236	FSC1236W
42"	FSC1242	FSC1242W
48"	FSC1248	FSC1248W
54"	FSC1254	FSC1254W
60"	FSC1260	FSC1260W
66"	FSC1266	FSC1266W
72"	FSC1272	FSC1272W

- Shelf designed for 12" deep Sigma Flex™ cores (part numbers - FLS's and BIU's)
- Installed between uprights on the inside of the island core upper frames.
- Steel shelf complete with brackets and keys. Wood shelves require Island Center Shelf Brackets, see below to order.
- Nominal width.

Island Center Shelf Brackets For 12" Deep Cores

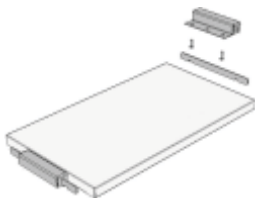

Item Number

FSB2012

- Pair of brackets designed for non-metal center shelves for 12" deep Sigma Flex™ cores (part numbers - FLS's and BIU's).
- Installed between uprights on the inside of the island core upper frames.
- Adjustable in 1" increments.
- Attach to Sigma Flex™ uprights with screws.

SIGMA FLEX™

SHELF COMPONENTS

15° Angled Outer Shelf Brackets



Depth	Item Number
10"	ASB0010
12"	ASB0012
14"	ASB0014
18"	ASB0018

- Pair of steel end brackets designed to fit Outer Shelves and can be used for shelves of different materials.
- Shelf brackets designed at a fixed 15 degree angle.
- Adjustable in 1" increments.
- Brackets only compatible with Sigma Flex™ structure or Sigma Cart™.

Outer Shelf Brackets



Depth	Item Number
6"	FSB0006
8"	FSB0008
9"	FSB0009
10"	FSB0010
12"	FSB0012
14"	FSB0014
18"	FSB0018

- Pair of top end shelf brackets, can be used for shelves of different materials.
- Adjustable in 1" increments.
- Only compatible with Sigma Flex™ structure or Sigma Cart™.

Top Shelf Brackets



Depth	Item Number
6"	FIB0006
8"	FIB0008
10"	FIB0010
12"	FIB0012
14"	FIB0014
18"	FIB0018

- Pair of top end shelf brackets, can be used for shelves of different materials.
- Adjustable in 1" increments.
- Only compatible with Sigma Flex™ structure or Sigma Cart™.

Radius Outer Shelf Brackets



Depth	Item Number
6"	FSB3006
8"	FSB3008
9"	FSB3009
10"	FSB3010
12"	FSB3012
14"	FSB3014
18"	FSB3018

- Pair of top end shelf brackets, can be used for shelves of different materials.
- Adjustable in 1" increments.
- Only compatible with Sigma Flex™ structure or Sigma Cart™.

Radius Top Shelf Brackets



Depth	Item Number
6"	FIB3006
8"	FIB3008
10"	FIB3010
12"	FIB3012
14"	FIB3014
18"	FIB3018

- Pair of top end shelf brackets, can be used for shelves of different materials.
- Adjustable in 1" increments.
- Only compatible with Sigma Flex™ structure or Sigma Cart™.

Tapered Outer Shelf Brackets



Depth	Item Number
6"	FSB4006
8"	FSB4008
9"	FSB4009
10"	FSB4010
12"	FSB4012
14"	FSB4014
18"	FSB4018

- Pair of top end shelf brackets, can be used for shelves of different materials.
- Adjustable in 1" increments.
- Only compatible with Sigma Flex™ structure or Sigma Cart™.

Tapered Top Shelf Brackets



Depth	Item Number
6"	FIB4006
8"	FIB4008
10"	FIB4010
12"	FIB4012
14"	FIB4014
18"	FIB4018

- Pair of top end shelf brackets, can be used for shelves of different materials.
- Adjustable in 1" increments.
- Only compatible with Sigma Flex™ structure or Sigma Cart™.

SIGMA FLEX™

SHELF COMPONENTS

Wall Center Shelves For 8-3/4" Deep Cores

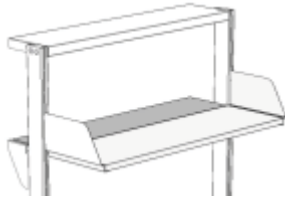

Width	Steel Shelves	Wood Shelves
24"	FSW0924	FSW0924W
30"	FSW0930	FSW0930W
36"	FSW0936	FSW0936W
42"	FSW0942	FSW0942W
48"	FSW0948	FSW0948W
54"	FSW0954	FSW0954W
60"	FSW0960	FSW0960W
66"	FSW0966	FSW0966W
72"	FSW0972	FSW0972W

- Shelf designed for wall conditions, only between back of upright and wall on 8-3/4" deep Sigma Flex™ wall cores (part number - FLW's).
- Nominal width.

Wall Center Shelf Brackets For 8-3/4" Deep Cores

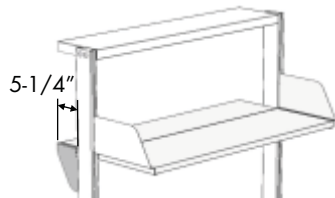

Item Number
FSB1006

- Pair of steel end brackets 5-1/4" deep used to support Wall Center Shelf between back of upright and wall.
- Adjustable in 1" increments.
- Brackets only compatible with Sigma Flex™ 8-3/4" Deep Wall Core assemblies.
- This bracket cannot be modified.

Monitor Arm and Mounting Brackets



Anodized Silver Finish	Black Finish
MONARMA	MONARMF

- LCD Monitor Arm with brackets to attach to Sigma Flex™ uprights.
- Adjustable in 1" increments.
- Brackets only compatible with Sigma Flex™ and Sigma Carts™ structures.

Under Mount LED Shelf Task Lights



Length of Light	Item Number
15"	TLW0015
24"	TLW0024
37"	TLW0037
49"	TLW0049
60"	TLW0060

- Order light a minimum 6" shorter than the shelf.
- UL Listed Low profile (15/16" wide by 1-9/16" high), white LED task light mounts to underside of the shelf and plugs into the receptacle
- 50,000 hour life rating, 4000k cold temperature, high efficiency with 87 lumens/watt, 60 foot-candles when shelf is 22" above the work surface.
- In-line on-off rocker switch located on the fixture. A white power plug and 78" long cable come standard with each light. Polycarbonate lens protects the lamp.
- Ships loose, includes screw-in plastic mounting clips. Optional magnetic mounting clips for steel shelves are available, use option code MC.

Task Light Flexible Connectors



Length	Item Number
11"	LFC0011
19"	LFC0019
39"	LFC0039

- White Flexible Connector allows to easily link LED lights in one continuous line. A maximum interconnection of 12 light fixtures. Only for use with Under Mount LED Shelf Task Lights. Ships loose.

SIGMA FLEX™

SERVICE CHANNELS

Single Sided Sigma Flex™ Service Channels

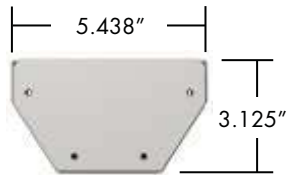

Electrical Service Channel	
Height	Item Number
12"	SFC1100
24"	SFC2100

- Heights available in 12" and 24".
- Cutouts only provided, fixtures, cover plates and plugs not included.
- Two electrical cutouts on a 12" high and four electrical cutouts on a 24" high.
- Not pre-wired. If required please contact Mott.
- Complete with mounting bracket.

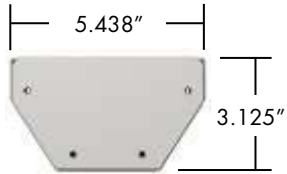

Fixture Service Channel	
Height	Item Number
12"	SFC1200
24"	SFC2200

- Heights available in 12" and 24".
- Cutouts only provided, fixtures, cover plates and plugs not included.
- Two plumbing cutouts on a 12" high and four plumbing cutouts on 24" high.
- Not pre-plumbed. If required please contact Mott.
- Complete with mounting bracket.

Double Sided Sigma Flex™ Service Channels

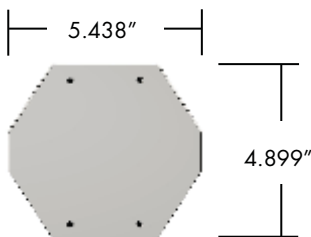

Electrical Service Channel	
Height	Item Number
12"	DFC1100
24"	DFC2100

- Heights available in 12" and 24".
- Cutouts only provided, fixtures, cover plates and plugs not included.
- Four electrical cutouts on a 12" high and eight electrical cutouts on a 24" high.
- Not pre-wired. If required please contact Mott.
- Complete with mounting bracket.

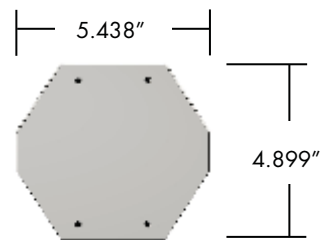

Fixture Service Channel	
Height	Item Number
12"	DFC1200
24"	DFC2200

- Heights available in 12" and 24".
- Cutouts only provided, fixtures, cover plates and plugs not included.
- Four plumbing cutouts on a 12" high and eight plumbing cutouts on 24" high.
- Not pre-plumbed. If required please contact Mott.
- Complete with mounting bracket.

SIGMA FLEX™

WALL PILASTERS

Sigma Flex™ Wall Pilasters

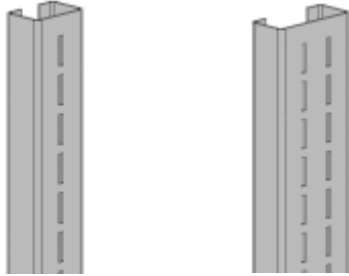

Height	Single Slotted	Double Slotted
18"	FPA1018	FPA0018
24"	FPA1024	FPA0024
30"	FPA1030	FPA0030
36"	FPA1036	FPA0036
42"	FPA1042	FPA0042
48"	FPA1048	FPA0048
60"	FPA1060	FPA0060
72"	FPA1072	FPA0072
96"	FPA1096	FPA0096

- Single Slotted Pilasters are 13/16" deep by 1-1/4" wide.
- Double Slotted Pilasters are 13/16" deep by 2-1/2" wide.
- Pilasters are adjustable in 1" increments.
- Fastens to wall to give support structure where no services are required.
- Ensure wall is of sufficient strength to support intended load (significant blocking required).
- Accepts Sigma Flex™ shelves and brackets.

