

OPTIMA™ MOBILE WORKSTATION

Optima™ Mobile Workstation

Mobile, adjustable and self contained workstations designed to enhance lab productivity. With a push of a button the work surface adjusts to meet the height demands of individual users and equipment. Add plumbing and shelving to meet your specific requirements. You can easily reconfigure lab layouts as needs change; simply move it where you need it, when you need to. The answer to flexibility to accommodate the ever-changing requirements in today's laboratories.



Optima™ Mobile Workstation
Double Sided Assembly



Optima™ Mobile Workstation
Single Sided Assembly

For additional information and help in planning contact Mott Manufacturing.

OPTIMA™ MOBILE WORKSTATION

Parts List

- 1) Optima™ Workstation Posts
 - 2) Optima™ Workstation Table Frame
 - 3) Optima™ Workstation Light Carrier Assembly
 - 4) Optima™ Workstation Lower Service Chase Assembly
 - 5) Optima™ Workstation Heavy Duty Casters
 - 6) Optima™ Workstation End Panels
- Note: Image shown of a 60" wide Double Sided Assembly

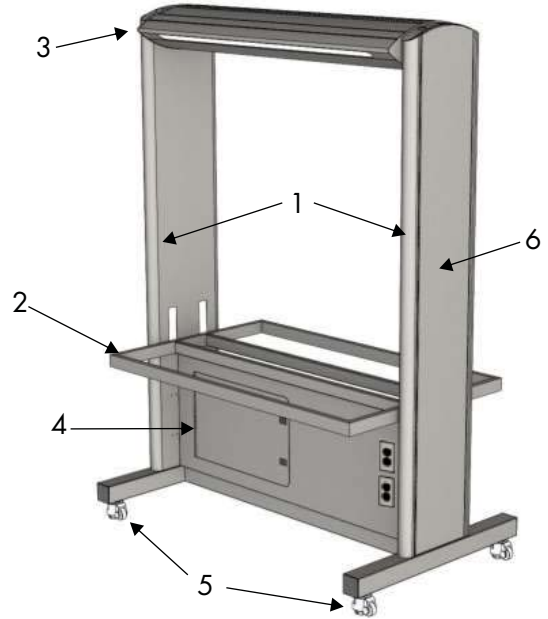

Load Ratings

Maximum load ratings are live loads and include loads applied to top of work surface, including total weight of shelves. These capacities should be used as guidelines only. Please contact Mott Manufacturing for specific load requirements. Maximum load ratings are based on the load being evenly balanced on both sides and does not include the weight of the work surface. Individual component or assembly load ratings should not be exceeded for any surface.



Single Sided Assembly

Maximum Load Rating

Adjustable Work Surface

- Cantilevered Work Surface 600lbs

Shelving

- 15" deep Lower Shelf 100lbs
- 15" deep Upper Shelf 100lbs

Total Assembly

- Shelving 800lbs
- Workstation 800lbs

Includes one work surface at 600lbs, and any combination of shelves.



Double Sided Assembly

OPTIMA™ MOBILE WORKSTATION

CIRCUIT DETAILS

Single Sided Assembly Circuit Details

Standard Wiring: 1 Circuit

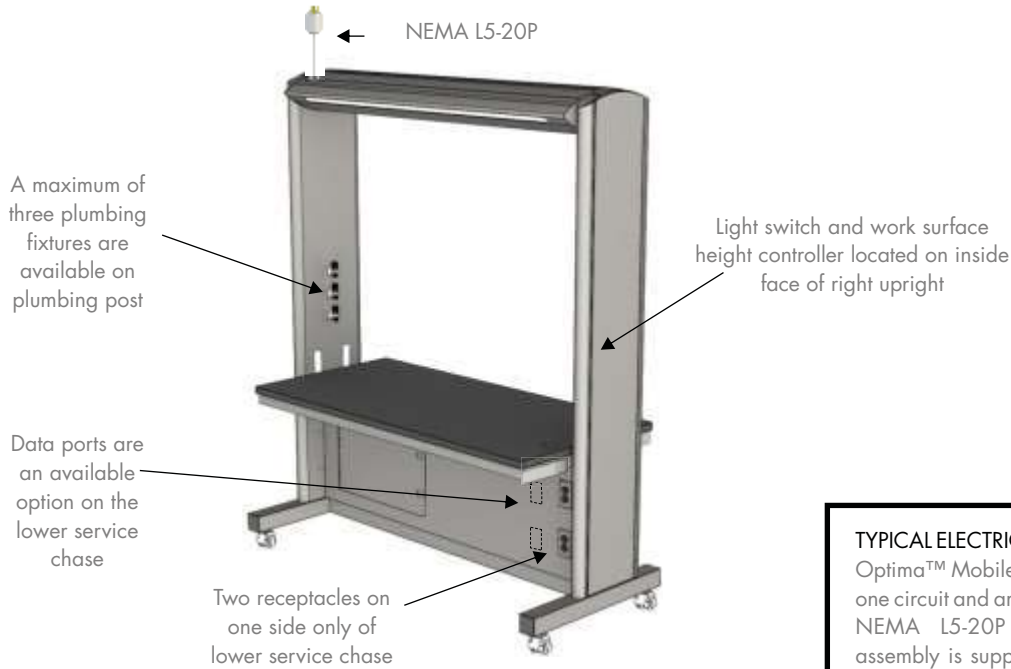

TYPICAL ELECTRICAL PLUG DETAIL

Optima™ Mobile Workstation comes with one circuit and are typically equipped with NEMA L5-20P locking plugs. Each assembly is supplied with 4 feet of white electrical cord.

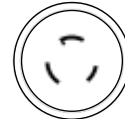

Note: All electrical receptacles and data ports with cover are black.

Double Sided Assembly Circuit Details

Standard Wiring: 1 Circuit



OPTIMA™ MOBILE WORKSTATION

Single Sided Assembly

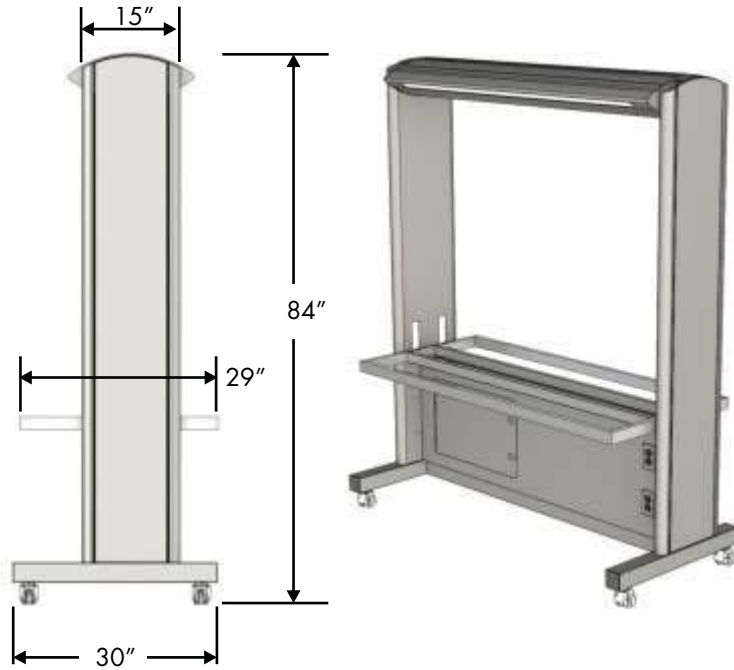

Width	Item Number
48"	OMW3048
60"	OMW3060
72"	OMW3072

- Workstation has a powder coated steel finish.
- Overall assembly is 84" high with 15" deep x 2-1/2" thick uprights. Overall depth of Single Sided Assembly is 30" deep (does not include work surface).
- Electro-hydraulic height adjustable table frame with electric motor has the flexibility to be raised or lowered from 29" to 35" (work surface not included).
- Complete with overhead task lights, light switch, two receptacles on lower service chase.
- Shipped assembled.

Double Sided Assembly

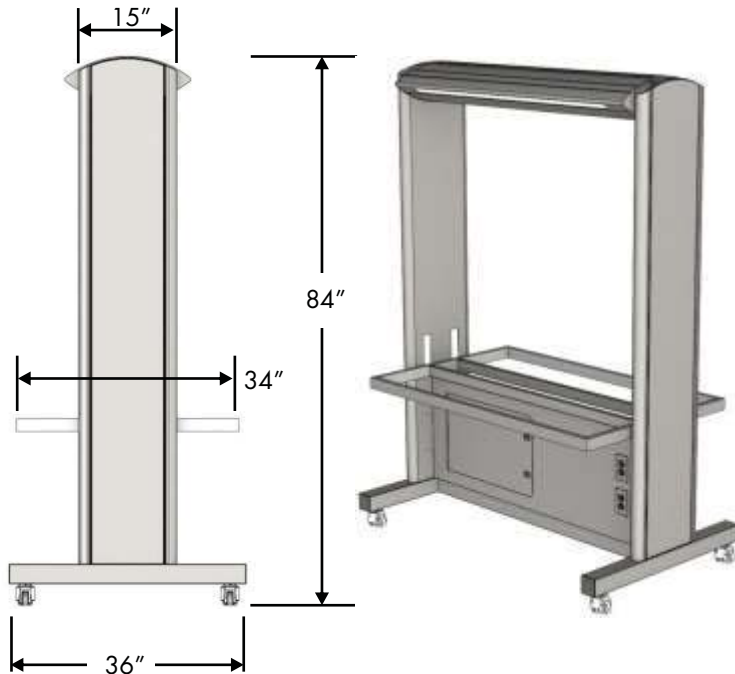

Width	Item Number
48"	OMW3648
60"	OMW3660
72"	OMW3672

- Workstation has a powder coated steel finish.
- Overall assembly is 84" high with 15" deep x 2-1/2" thick uprights. Overall depth of Double Sided Assembly is 36" deep (does not include work surface).
- Electro-hydraulic height adjustable table frame with electric motor has the flexibility to be raised or lowered from 29" to 35" (work surface not included).
- Complete with overhead task lights, light switch, four receptacles two per side on lower service chase.
- Shipped assembled.