

# Stainless Steel

Care and Cleaning

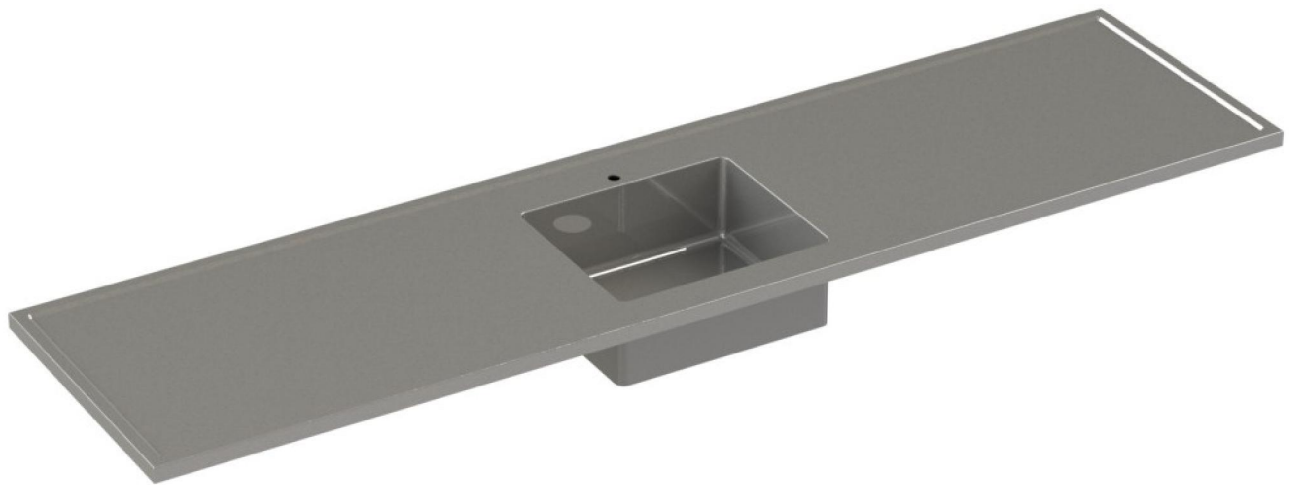

Mott Manufacturing Limited  
452 Hardy Road  
Brantford, Ontario  
N3T 5L8  
Canada



**SAVE THESE INSTRUCTIONS**

# **Table of Contents**

Introduction .....	Pg.3
Care of Stainless Steel .....	Pg.3
Cleaning Stainless Steel.....	Pg.4
Types of Surface Contaminants .....	Pg.4
Types of Cleaners and Methods .....	Pg.5
Effective Cleaning Methods.....	Pg.6
Scratch Repair.....	Pg.7
References .....	Pg.7

## ***Introduction***

This manual is intended to supplement the instructions for Fume Hoods and Casework when optional stainless steel construction has been specified. Care and cleaning instructions are also applicable to stainless steel countertops and other stainless steel products.

## ***Care of Stainless Steel***

Stainless steel products provided by Mott Manufacturing Limited have a directional #4 brushed finish. This finish is produced using a very fine abrasive cloth. Any mechanical damage such as dragging heavy equipment across the stainless steel surfaces will cause noticeable scratching. Scratches can generally be repaired (see page 8). Pitting/corrosion of stainless steel can be caused when carbon steel products are allowed to remain in contact with the stainless steel in the presence of moisture. Examples of this are Steel Wool pads left in the bottom of the sink and metal flakes from drilling or machining operations allowed to remain on the stainless steel.

Stainless steel can be damaged by exposure to acids. A partial list of reagents that may cause staining and damage to stainless steel is provided below. Contact Mott Manufacturing for more information or a complete list:

- Chlorosulphonic acid
- Ferric Chloride
- Ferrous Chloride
- Ferrous Iodide
- Flourine
- Hydrochloric acid
- Hydrobromic acid
- Hydrofluoaailic acid
- Hydroflouric acid
- Iodine
- Silver Chloride
- Sodium Biflouride
- Sodium Chlorite (304 only, 316 OK)
- Sodium Hypochlorite
- Stannic Chloride
- Sulphur Chloride
- Sulphuric acid
- Trichloroacetic acid
- Uranium Trichloride

If damage or staining occurs, the surface finish may be repaired after neutralization and cleaning by following the scratch removal method outlined on page 7.

Chlorine bleach will attack the stainless steel and may cause pitting. The risk of damage is proportional to the concentration of the chlorine and the duration of exposure between the sink and the chlorine agent. Note that some antibacterial soap may contain chlorine compounds: Always dilute any antibacterial product used and wipe up any spills.

## *Cleaning Stainless Steel*

Stainless steels need to be cleaned for aesthetic considerations and to preserve corrosion resistance. Stainless steel is protected from corrosion by a thin layer of chromium oxide. Oxygen from the atmosphere combines with the chromium in the stainless steel to form this passive chromium oxide film that protects from further corrosion. Any contamination of the surface by dirt, or other material, hinders this passivation process and traps corrosive agents, reducing corrosion protection. Thus, some form of routine cleaning is necessary to preserve the appearance and integrity of the surface. Stainless steels are easily cleaned by many different methods. They actually thrive with frequent cleaning, and, unlike some other materials, it is impossible to “wear out” stainless steel by excessive cleaning.

### *Types of Surface Contaminants*

**Dirt** - Like any surface that is exposed to the environment, stainless steel can get dirty. Dirt and soil can consist of accumulated dust and a variety of contaminants that come from many sources. These contaminants will vary greatly in their effect on appearance and corrosivity and ease of removal. While some may be easily removed, others may require specific cleaners for effective removal. It may be necessary to identify the contaminant or experiment with various cleaners. Frequently, warm water with or without a gentle detergent is sufficient. Next in order are mild non-scratching abrasive powders such as typical household cleaners. These can be used with warm water, bristle brushes, sponges, or clean cloths. ***Ordinary carbon steel brushes or steel wool should be avoided as they may leave particles embedded on the surface which can lead to RUSTING.*** For more aggressive cleaning, a small amount of vinegar can be added to the scouring powder. ***Cleaning should always be followed by rinsing in clean hot water.*** When water contains mineral solids, which leave water spots, it is advisable to wipe the surface completely with dry towels.

**Fingerprints and Stains** - Fingerprints and mild stains resulting from normal use are the most common surface contaminants. Fortunately, these usually affect only appearance and seldom have an effect on corrosion resistance. They are easy to remove by a variety of simple cleaning methods. Fingerprints are probably the most troublesome marks to remove from the surface of smooth polished or bright finished stainless steel. Fortunately, they can be removed with a glass cleaner or by gentle rubbing with a paste of soda ash (sodium carbonate) and water applied with a soft rag. Once again, this should be followed by a thorough warm water rinse.

**Shop oil and Grease** - Shop oils, which may carry grease, grit and metal chips, commonly produce surface soiling after many shop operations. Greases and other contaminants may also soil surfaces in food preparation and many other household and commercial situations. These soils may be corrosive in themselves or may not allow the surface to maintain passivity, and so periodic removal is a necessity. Initially, soap or detergent and water may be tried or a combination of detergent and water plus a solvent. This process, in its simplest form, consists of bringing liquid solvent into contact with the surface to be cleaned and allowing dissolution to

take place; for example, washing a surface with trichloroethylene or similar liquid. Non-halogenated solvents, such as acetone, methyl alcohol, ethyl alcohol, methyl ethyl ketone, benzene, isopropyl alcohol, toluene, mineral spirits, and turpentine work well. Many of these solvents are widely used as individual cleaners, but there are thousands of blended or compound cleaners on the market. Users are advised to contact suppliers of solvents for information on their applications on stainless steel.

## ***Types of Cleaners and Methods***

### **General Precautions**

In selecting cleaning practices, consider the possibility of scratching and the potential for post-cleaning corrosion caused by incompletely removed cleaners. Scratching can be caused by cleaners that contain hard abrasives, or even by “grit” in wash water. This is usually not a problem on dull finishes, or those surfaces finished with a coarse polishing grit. The best preventative measure is to avoid using abrasive cleaners unless absolutely necessary. When abrasives are needed, first experiment on an inconspicuous area. A “soft abrasive,” such as pumice, should be used. Many cleaners contain corrosive ingredients which require thorough post-clean rinsing with clean water; however, thorough rinsing is recommended for all cleaning procedures.

**Clean Water and Wipe** - The simplest, safest, and least costly method that will adequately do the job is always the best method. Stainless surfaces thrive with frequent cleaning because there is no surface coating to wear off stainless steels. A soft cloth and clean warm water should always be the first choice for mild stains and loose dirt and soils. A final rinse with clean water and a dry wipe will complete the process and eliminate the possibility of water stains.

**Solvent Cleaning** - Organic solvents can be used to remove fresh fingerprints and oils and greases that have not had time to oxidize or decompose. The preferred solvent is one that does not contain chlorine, such as acetone, methyl alcohol, and mineral spirits. There are many compounded or blended organic cleaners that are commercially available and attempt to optimize both clean ability and safety attributes. Cleaning can be accomplished by wiping with solvent-impregnated cloths, or by sophisticated vapor or spray methods. The wiping technique sometimes leaves a streaked surface.

## *Effective Cleaning Methods*

<b>Job</b>	<b>Cleaning Agents*</b>	<b>Comments</b>
Routine Cleaning	Warm Water, Soap, Ammonia, Detergent	Apply with sponge or soft cloth. Can be used on all finishes.
Fingerprints and Smears	3M Stainless Steel Cleaner and Polish Arcal 20, Lac-O-Nu, Lumin Wash, O’Cedar Cream Polish, Stainless Shine	Provides barrier film to minimize fingerprints. Can be used on all finishes.
Stubborn Stains and Discoloration	3M Stainless Steel Cleaner and Polish Allchem Concentrated Cleaner, Samae Twinkle, Cameo Copper Cleaner, Grade FFF. or Grade F Italian Pumice, Whiting or talc, Liquid Nu Steel, Copper’s or Revere Stainless Steel Cleaner, Household Cleaners, Lumin Cleaner, Zud Restoro, Sta-Clean, Highlite, Allen Polish, Penny-Brite, Copper-Brite	Rub lightly, using dry damp cloth, in the direction of polish lines on the stainless steel
Grease and Blood, Burnt-on or Baked-on Foods	De-Grease-It, 4% to 6% hot solution of such agents as tri-sodium polyphosphate, 5% to 15% caustic soda solution	Excellent removal on acids, all finishes Particularly useful where rubbing is not practical.
Grease and Oil	Any good commercial detergent or caustic cleanser	Apply with sponge or soft cloth in direction of polish lines.

**\*NOTE:** Use of proprietary names is intended only to indicate a type of cleaner and does not constitute an endorsement. Omission of any proprietary cleanser does not imply its inadequacy. All products should be used in strict accordance with instructions on package.

**Household Cleaners** - Household cleaners fall into two categories: detergent (nonabrasive) and abrasive cleaners. Both are effective for many mild dirt, stain, and soil deposits, as well as light oils such as fingerprints. The abrasive cleaners are more effective but introduce the possibility of scratching the surface. However, the degree of abrasiveness will vary greatly with the particular product, and some brands will produce noticeable scratching on only the most highly polished surfaces. All of these cleaners vary widely with respect to their acidity and the amount of chloride they contain. A neutral cleaner low in chloride is preferred unless the user is assured that the surface can be thoroughly rinsed after cleaning. The fact that the label states “for stainless steel” is no guarantee that the product is not abrasive, not acidic, or low in chloride. The cleaning method generally employed with these cleaners is to apply them to the stainless surface

and follow by cloth wiping, or to wipe directly with a cleaner-impregnated soft cloth. In all cases, the cleaned surface should be thoroughly rinsed with clean water and wiped dry with a soft cloth if water streaking is a consideration.

**Commercial Cleaners** - Many commercial cleaners compounded from phosphates, synthetic detergents, and alkalis are available for the cleaning of severely soiled or stained stainless surfaces. When used with a variety of cleaning methods, these cleaners can safely provide effective cleaning. Manufacturers should be consulted and their recommendations followed whenever using cleaners of this kind. The general precautions stated above also pertain to these cleaners.

## ***Scratch Repair***

Surface scratches can be repaired using the following technique. Depending on the severity of the scratch, it may be possible to completely remove it.

Sand the scratch using 120 grit emery cloth or paper and firm pressure. Always sand in the direction of the grain. Avoid the natural tendency to sand in an arc, instead sand in a perfectly straight line. Sand until the scratch is gone.

Polish using 3M Scotch Brite Pads - Very Fine Grade. Use the same motions as with sanding. Polish until the original finish is restored.

## ***References***

Much of the cleaning portion of this document was adapted from:

Specialty Steel Industry of North America. Care and Cleaning of Stainless Steel. Specialty Steel Industry of North America, 3050 K Street, N.W. Washington, D.C. 20007 ([www.ssina.com](http://www.ssina.com))