

STAINLESS STEEL PRODUCTS

Stainless Steel Introduction

The full range of Mott cabinetry - from base cabinets to tall floor mounted cabinets - are available in 304 or 316 stainless steel. Mott Manufacturing specializes in the integration of custom design features and/or dimensions into stainless steel laboratory furniture components. The following is a sample listing of other furniture components that can be manufactured in 304 or 316 stainless steel:

- Counter tops
- Filler panels
- Aprons
- Tables - fixed and mobile
- Exhaust canopies

Stainless Steel Grades

The most common stainless steel grades required in laboratory applications are 304 or 316. 304 grade is widely used for cabinetry while the 316 grade is more often specified for more demanding applications such as counter tops and fume hood liners.

304 grade stainless steel is the most versatile and one of the most widely applied stainless steel grades for laboratory use. High quality laboratory furniture components can be readily manufactured from this grade because it has excellent forming and welding characteristics. This grade also has excellent corrosion resistance, further corrosion resistance details are available from Mott Manufacturing or its dealers upon request.

316 grade stainless steel is specified for the more demanding laboratory environments. This molybdenum bearing, higher nickel content grade delivers superior corrosion resistance, improved stain resistance and strengthened chloride attack resistance benefits to laboratory furniture. This grade has excellent corrosion resistance to a wider range of chemicals, including the complex sulphur compounds.

All Mott stainless steel laboratory furniture components are manufactured to a No.4 finish to deliver a smooth sanitary surface. This finish is widely used in laboratory applications where a uniform bright finish is required. The No.4 finish delivered by Mott Manufacturing is often slightly brighter than industry standard as the mesh finish is in the range of 120 to 150 resulting from the stainless steel sheets being polished with lubricating oil and abrasive belts with a

180 to 200 grit. No.4 finish samples are available from Mott or its dealers upon request.

Counter Tops

Counter tops can be designed to exactly match customer specifications and include features such as:

- Marine or finished edges (figure 1)
- Integral sinks in a wide variety of configurations
- Sloping drain boards

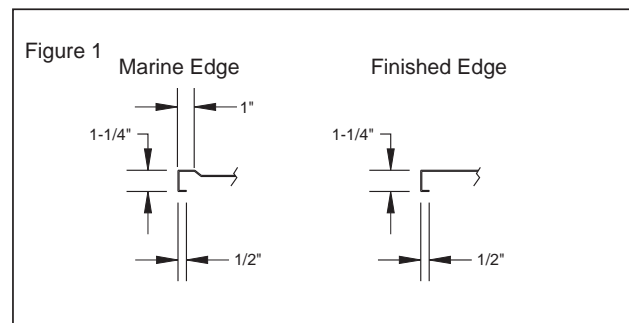

Standard construction includes either 304 or 316 stainless steel, backed by a 43 lb density particle board and plywood core (figure 2). Steel hat channel

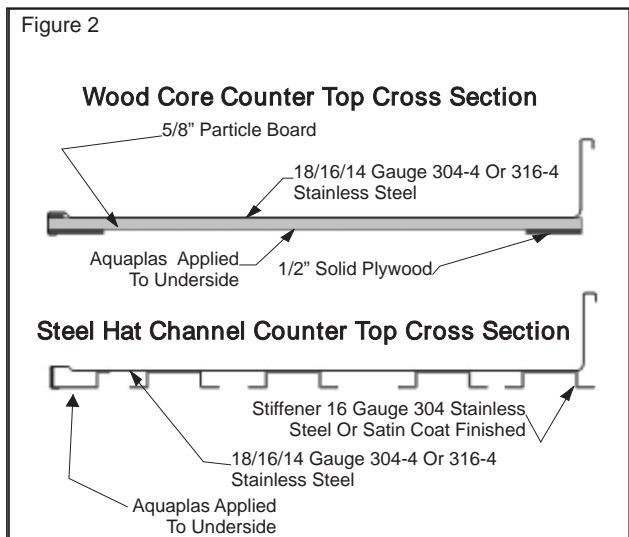

construction is also available with 16 gauge type 304 stainless steel or satin coat finished stiffeners. Hat channel construction is recommended for long length counter tops that support heavy equipment or instruments (figure 2). All Mott counter tops have a sound deadening Aquaplas sealer applied to their underside.

STAINLESS STEEL PRODUCTS

Exhaust Canopies

Exhaust canopies can be manufactured to customer specifications. Exhaust canopies are primarily used to exhaust steam, odors, and heat in work areas where the expense and capabilities of a fume hood are not justified. In addition to stainless steel, exhaust canopies are also available in painted galvanized or cold rolled steel. Features include:

- Integral duct stub
- Steel rod suspension
- Continuous condensate catch

Available options include:

- Interior lights
- Baffles
- Dampers

There are two basic types of stainless steel exhaust canopies, island exhaust canopies and wall exhaust canopies. Island exhaust canopies (figure 3) have four angled surfaces and are often used above an island workstation or where wall mounting is not practical. The sloped surfaces allow for easier housekeeping.

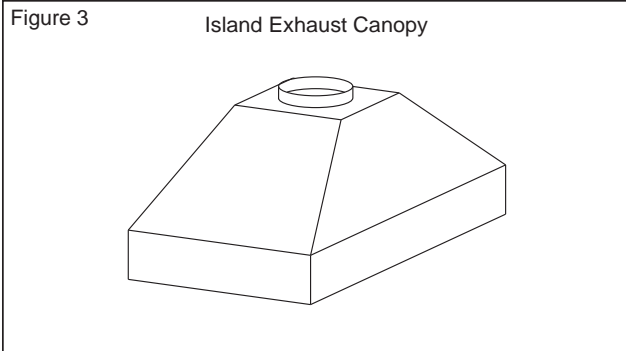

Wall exhaust canopies have 3 sloped surfaces and a flat rear surface to facilitate mounting to a wall (figure 4).

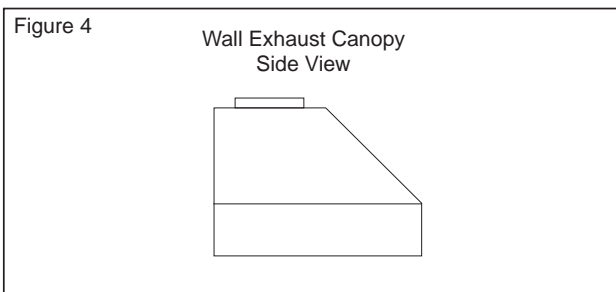

Exhaust canopies are most commonly constructed of 18 gauge 304 or 316 stainless steel.

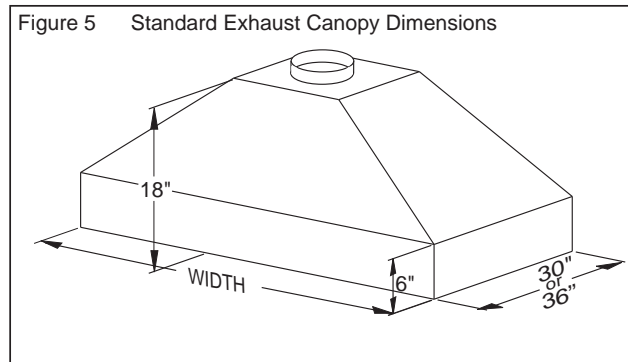

Exhaust canopies are manufactured to exact customer specifications. Part numbers for exhaust canopies are located on page P37 of the catalog.

Other Stainless Steel Products

All cabinets, filler panels, tables and aprons are available in stainless steel. Stainless steel cabinets are constructed of the same gauges of material as our standard product, but in 304-4 stainless and are equipped with stainless steel hinges and bar pulls.

- Drawer bodies, Shelves, Door & Drawer Liners, Removable Backs. 20 gauge
- Cabinet Gables, Tops, Bottoms, Toekicks, Outer Door and Drawer Front Panels, Table Frames, Filler Panels, Sloping Tops. 18 gauge
- Tops and Intermediate Channels, Table Legs. 16 gauge
- Drawer Suspension, Hinge Plates, Cabinet Leveler Support. 14 gauge

Ordering Stainless Steel Product

Ordering stainless steel cabinetry is accomplished by using our standard part numbers and stating any items to be made from stainless steel. Please specify the grade of stainless steel desired when ordering. Option code -51 is type 304-4 and option code -52 is type 316-4.

STAINLESS STEEL CASEWORK CONSTRUCTION DETAILS AND SPECIFICATIONS

Overview

Cabinets

Standard cabinets are fabricated using prime quality furniture grade 304-4 stainless steel. (Optional 316-4 Stainless Steel is also available using option code -51.) All components are die formed, notched, keyed and tightly fitted to form a

Stainless Steel Cabinet Gauges and Materials	
Drawer Bodies*, Shelves, Door and Drawer Liners, Removable Backs.	20 gauge 304-4 S/S
Cabinet Gables, Tops, Bottoms, Toekicks, Outer Door and Drawer Front Panels, Table Frames, Filler Panels, Sloping Tops.	18 gauge 304-4 S/S
Top and Intermediate Channels, Table Legs.	16 gauge 304-4 S/S
Drawer Suspension, Hinge Plates.	14 gauge 304-4 S/S
Cabinet Leveler Support	11 gauge 304-4 S/S
Five Knuckle Hinges (with s/s fasteners)	14 gauge 304-4 S/S
Door / Drawer Pulls	S/S Bar Pull
Door Roller Catch	Zinc Plated
3/8 Hex Head Leveler Bolts	Electro Plated
Drawer Roller Bearings	Zinc plated with Nylon rim
Full Extension Drawer Glides	Zinc plated
Shelf Clips	Zinc plated
Sliding Glass Doors Shoes & Tracks	Aluminum
Framed Glass Door lower Tracks	PVC
Cabinet Leveler Access Covers	PVC

Note: * 30" wide or larger drawers are 18 gauge, otherwise drawers are standard 20 gauge.

Finish

All cabinets surfaces are finished to a No.4 brush. All weld marks on the cabinet front and sides, exterior and interior of drawer / door heads have the color removed. All welds including the rear and interior of the cabinet, and outside of drawer housings are left natural.

